

NOTES, UNLESS OTHERWISE SPECIFIED:

1. RESISTANCE VALUES IN OHMS.
2. CAPACITANCE VALUES IN MICROFARADS.
3. REFERENCE DESIGNATORS USED:
4. ALL 0.1 uF AND 0.01uF CAPACITORS ARE DECOUPLING CAPS UNLESS OTHERWISE NOTED. THEY ARE SHOWN ON THE PAGE WITH THE INTEGRATED CIRCUITS THEY SHOULD BE PLACED NEAR.
5. NHET1xx means NHET1_[xx].
6. OBSERVE THE LAYOUT NOTES IN SCHEMATIC.

This schematics is for both TMS570LS31x and RM48 devices. They have same package. TMS570LS31x is Big-Endian device, but RM48 is Little-Endian device.

SCHEMATIC CONTENTS

- 01 TITLE SHEET
- 02 USB & FTDI
- 03 CPLD
- 04 MCU PINs
- 05 JTAG
- 06 DCAN & NC
- 07 Sensors & LEDs
- 08 Development Pins
- 09 Power

**Proprietary
&
Confidential**

Title		
RM48 USBSTICK		
Size A	Document Number Title	Rev A
Date:	Friday, July 27, 2012	Sheet 1 of 9

USB-A Connector

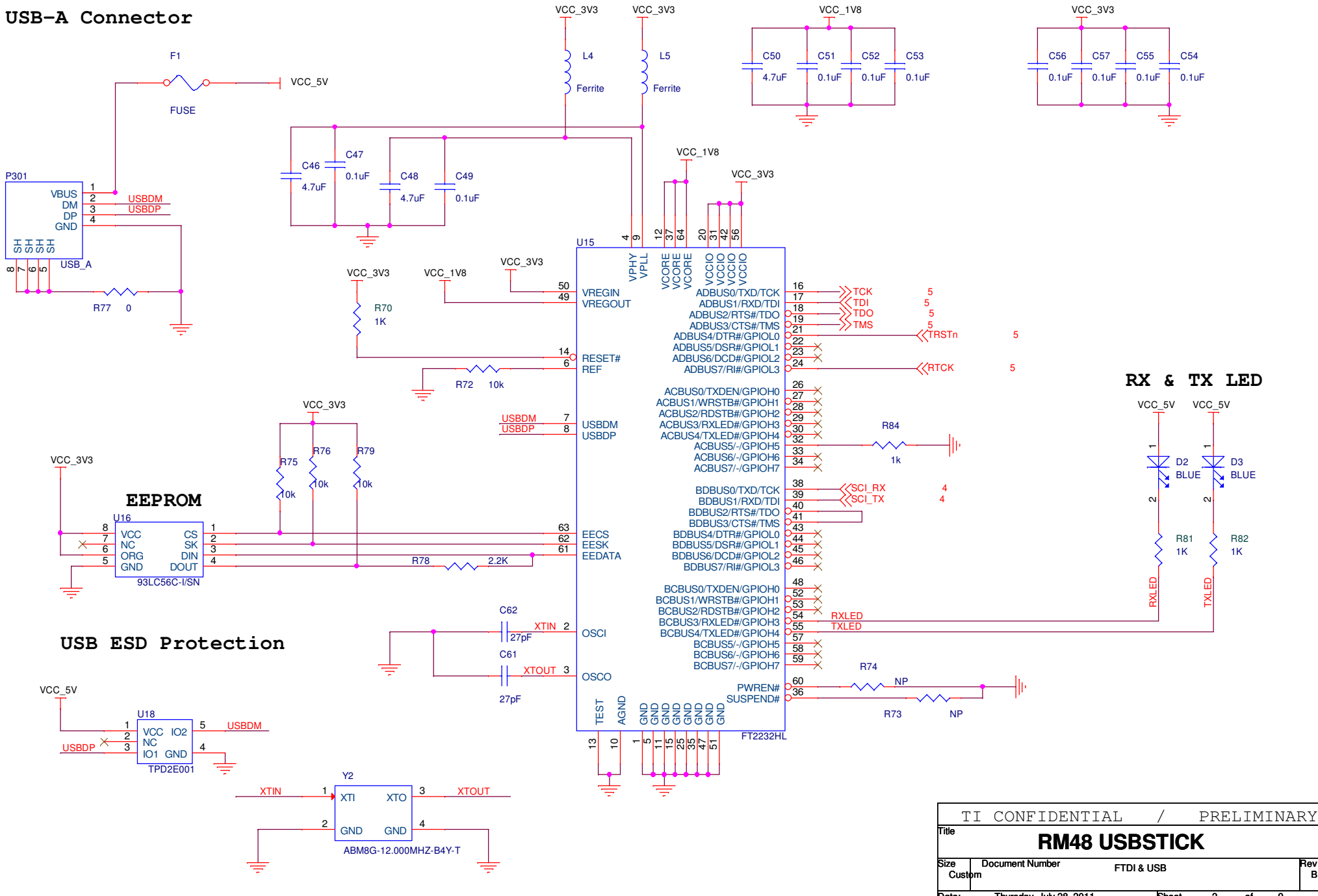

TI CONFIDENTIAL / PRELIMINARY	
Title RM48 USBSTICK	
Size Custom	Document Number FTDI & USB
Date: Thursday, July 28, 2011	Rev B
Sheet 2	of 9

Power-Ground on MCU

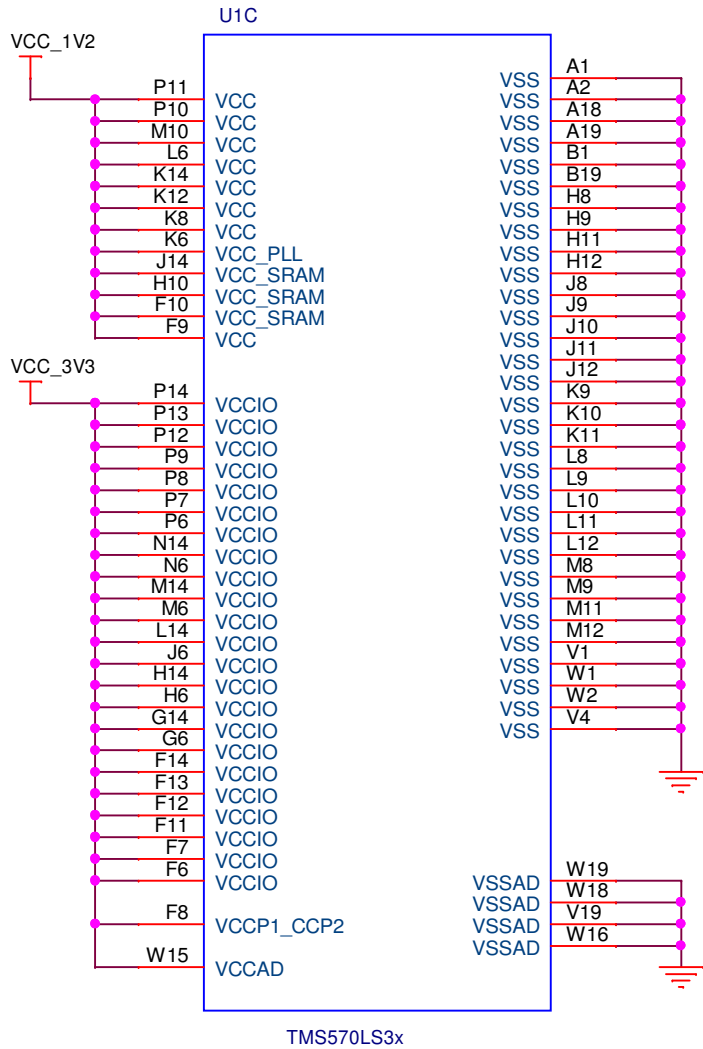

25 VCCIO+VCCAD+VCCP1/2 Pins

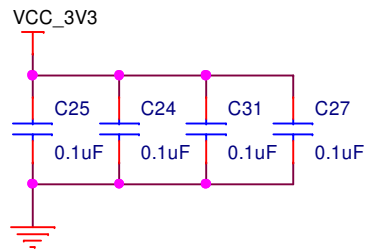
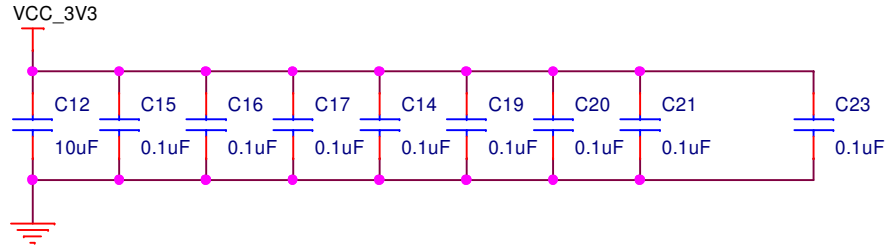

12 VCC pins

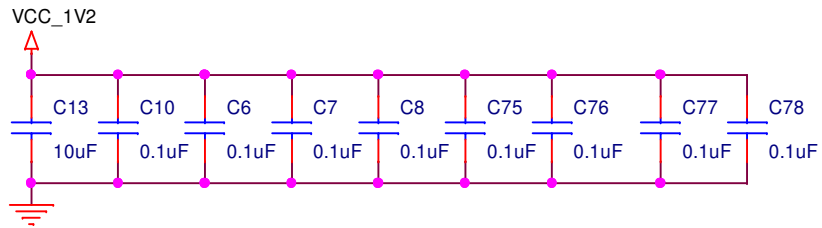

Title			RM48 USBSTICK		
Size A	Document Number				Rev A
	POWER and GND				
Date:	Friday, July 27, 2012			Sheet	3 of 9

MCU PINS

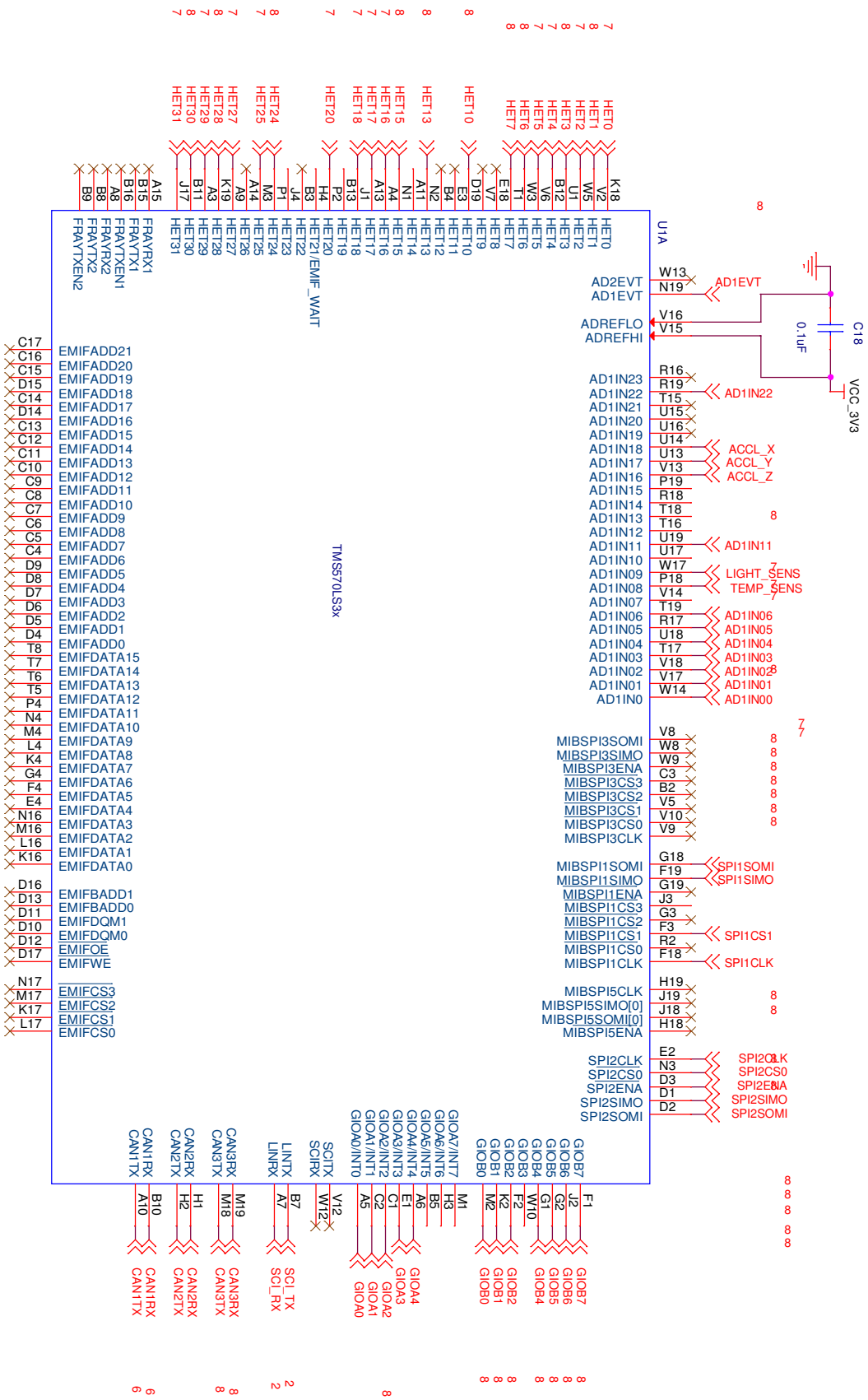

TI CONFIDENTIAL / PRELIMINARY	
RM48 USBSTICK	
Title	Document Number
Size	MCU Pins
Custom	Rev B
Date:	Thursday, July 28, 2011
Sheet	4 of 9

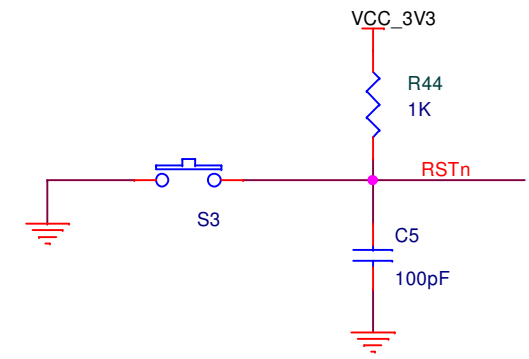
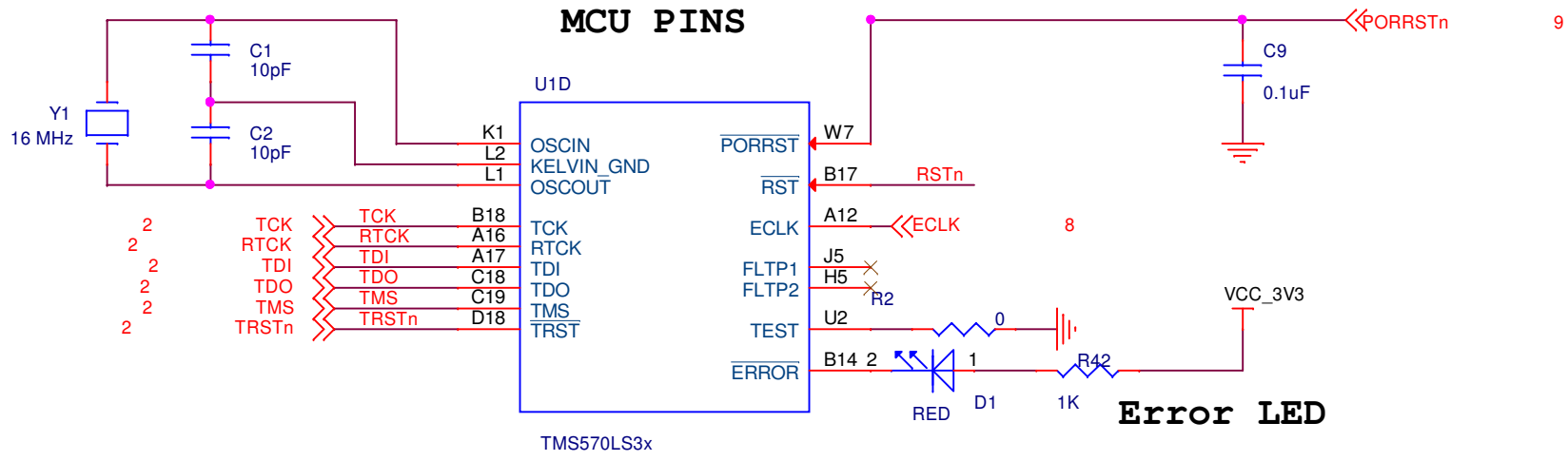

JTAG LED

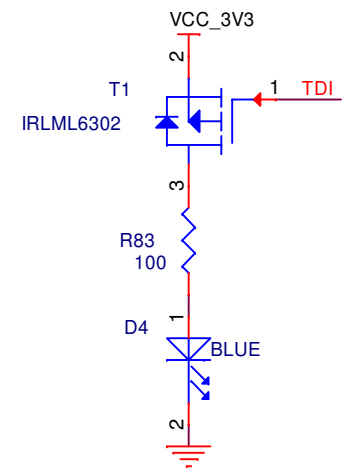

TI CONFIDENTIAL / PRELIMINARY	
Title	
RM48 USBSTICK	
Size	Document Number
A	JTAG
Date: Thursday, July 28, 2011	
Sheet	5 of 9
Rev	
B	

Unused Pins

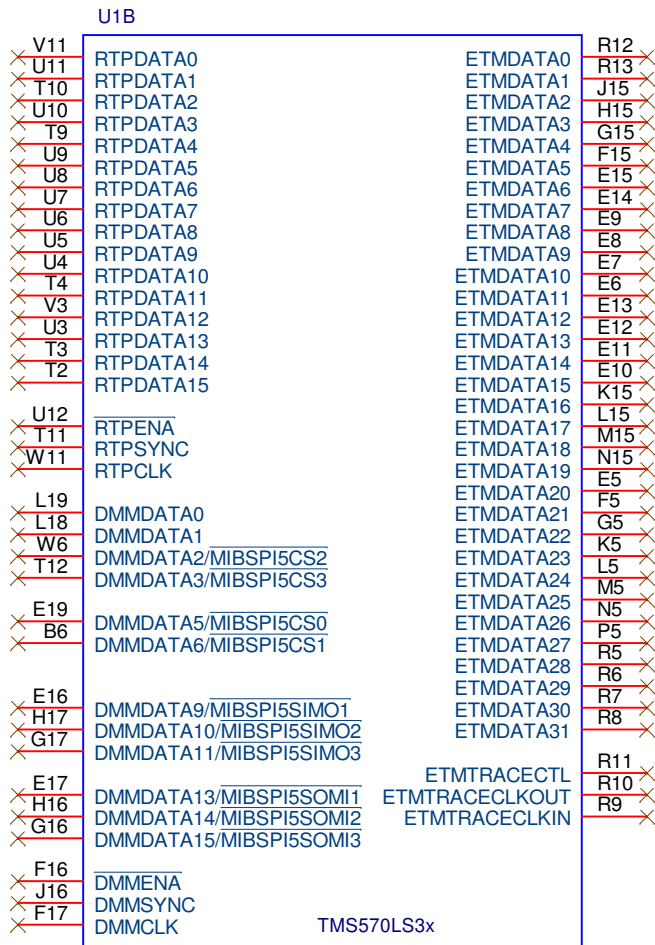

Can Transceiver

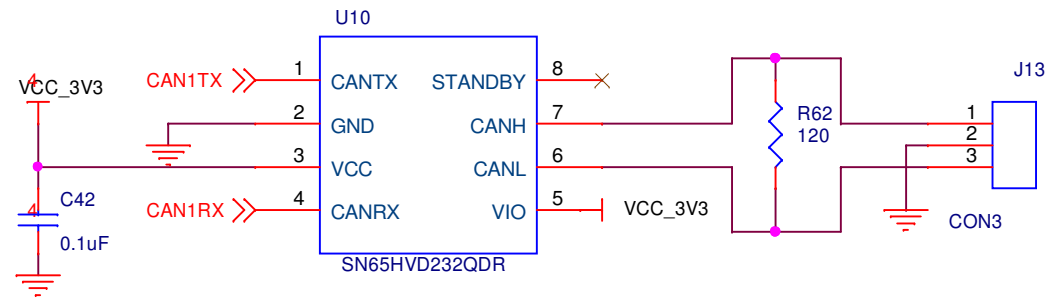

No Connects

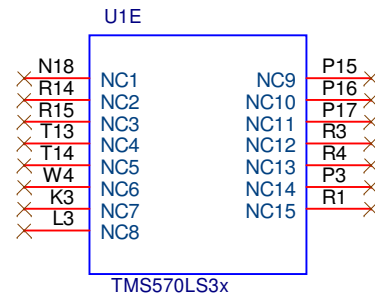

TI CONFIDENTIAL / PRELIMINARY

Title			
RM48 USBSTICK			
Size A	Document Number	DCAN & NC	Rev B
Date:	Thursday, July 28, 2011	Sheet	6 of 9

Tri-Color LEDs

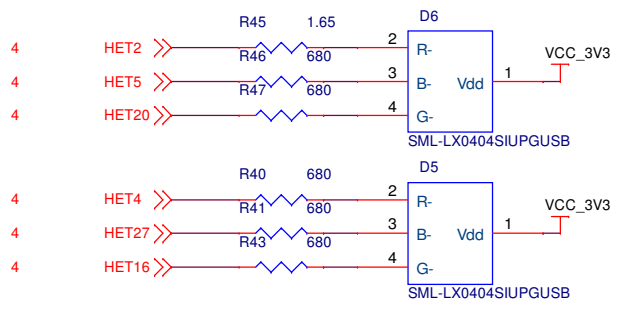

Temperature Sensor

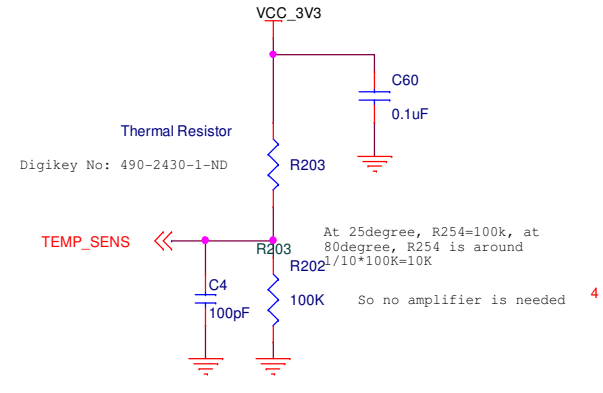

Light Sensor

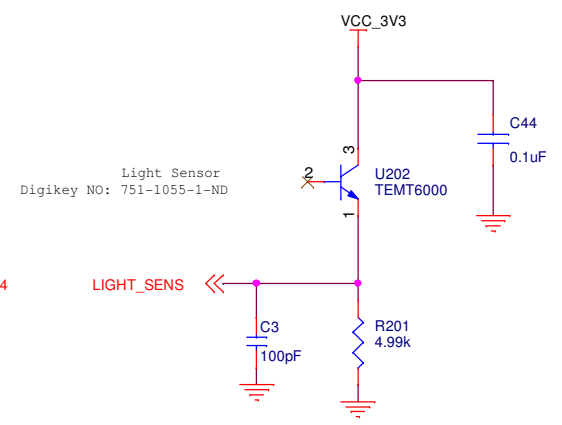

LEDs

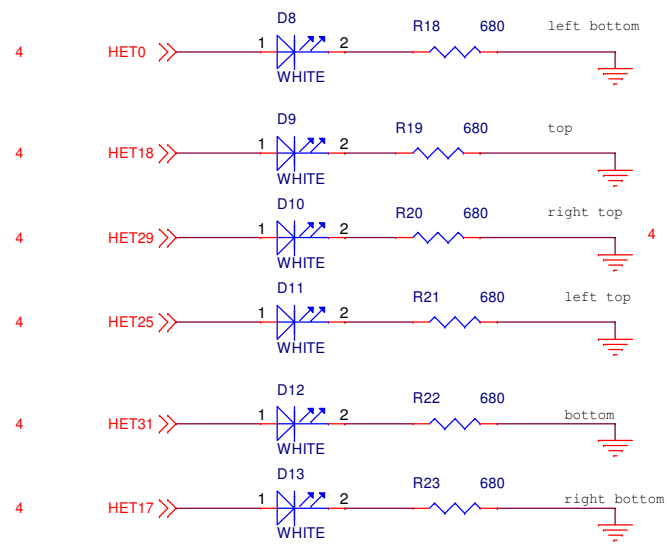

Accelerometer

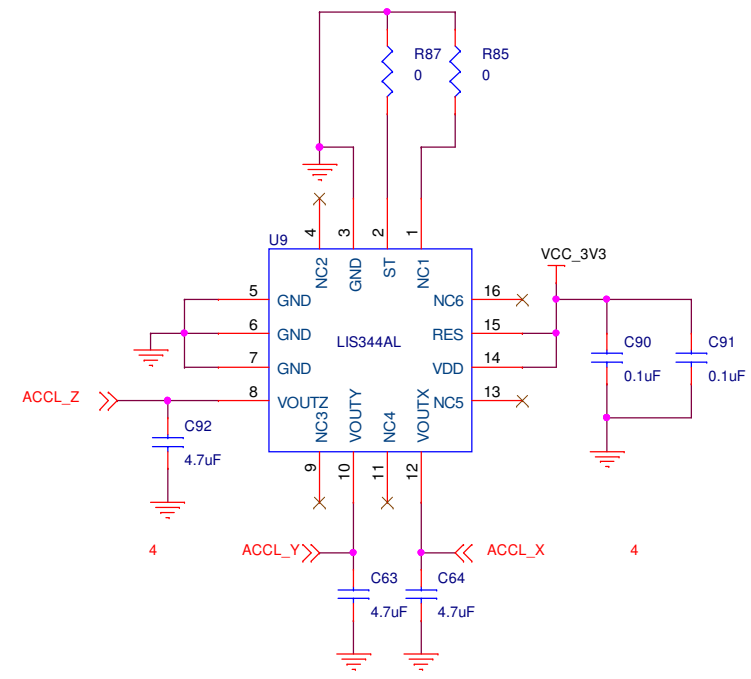

TI CONFIDENTIAL / PRELIMINARY			
Title			
RM48 USBSTICK			
Size	Document Number	Sensors & LEDs	Rev
Custom			B
Date:	Thursday, July 28, 2011	Sheet	7 of 9

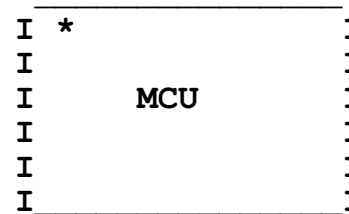
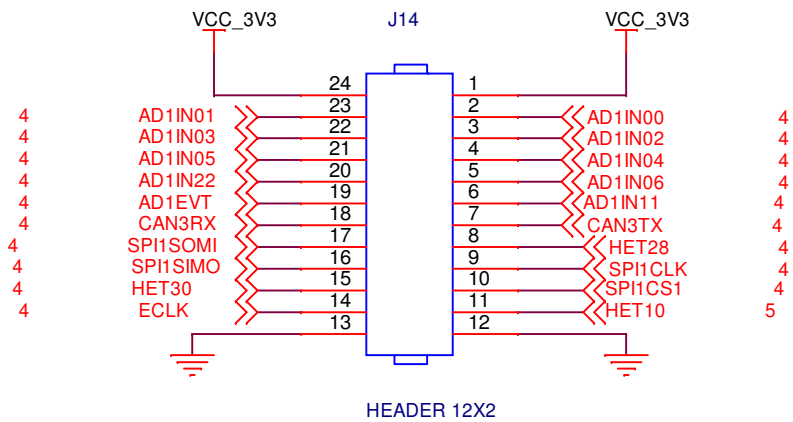
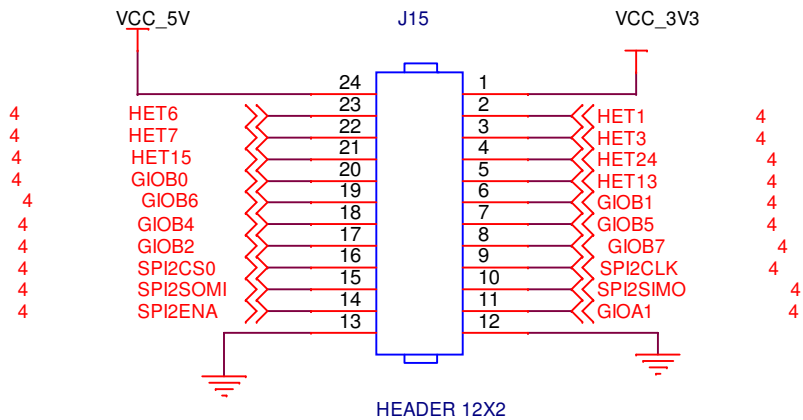

TI CONFIDENTIAL / PRELIMINARY			
Title			
RM48 USBSTICK			
Size A	Document Number	Development Pins	Rev B
Date:	Thursday, July 28, 2011	Sheet	8 of 9

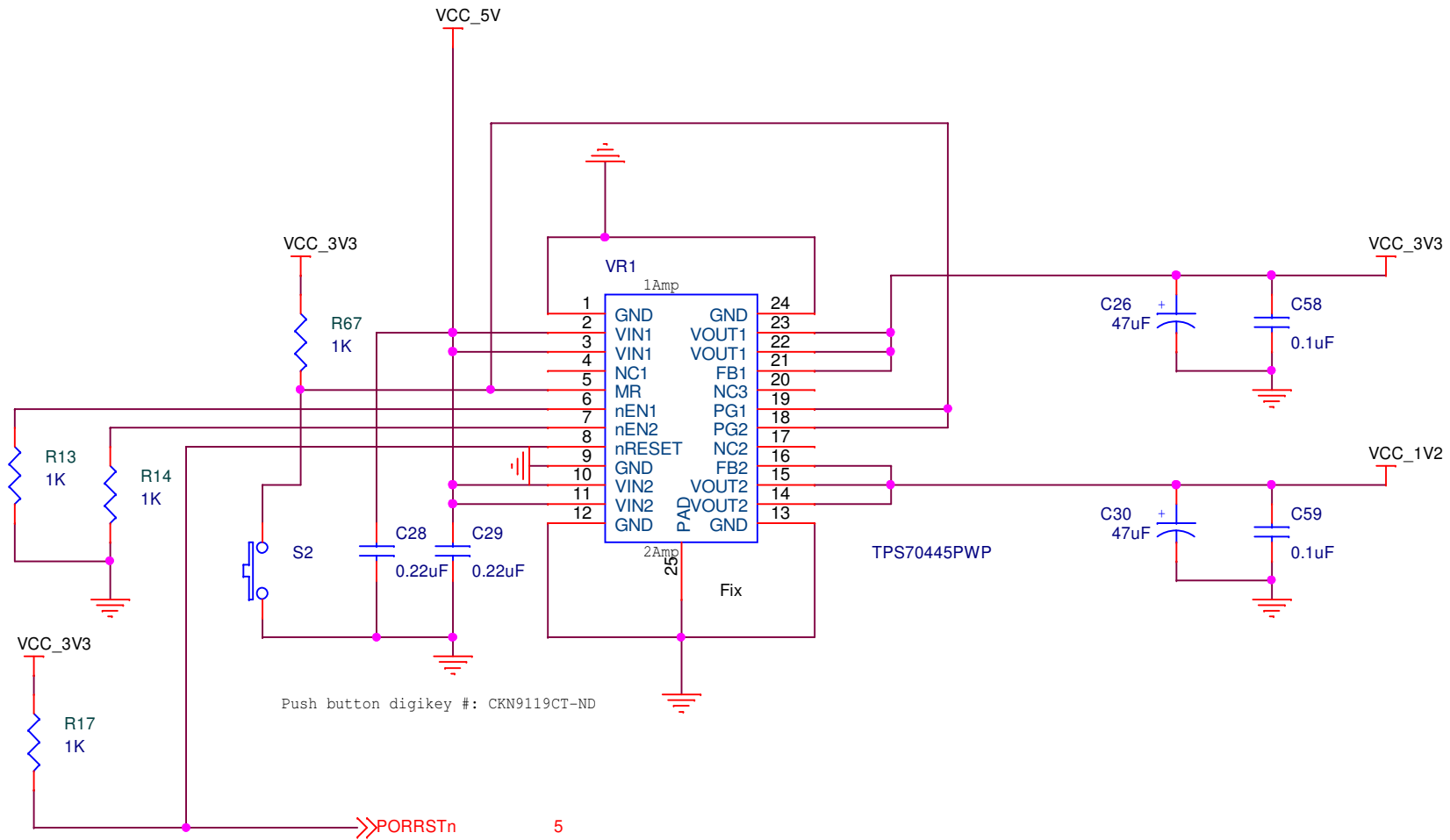

Power LED

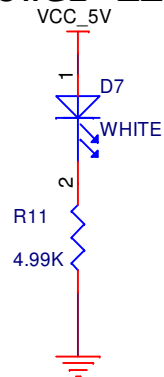

Title			
RM48 USBSTICK			
Size A	Document Number POWER	Rev B	
Date: Thursday, July 28, 2011		Sheet	9 of 9