

NOTES, UNLESS OTHERWISE SPECIFIED:

1. RESISTANCE VALUES IN OHMS.
2. CAPACITANCE VALUES IN MICROFARADS.
3. REFERENCE DESIGNATORS USED:
4. ALL 0.1 uF AND 0.01uF CAPACITORS ARE DECOUPLING CAPS UNLESS OTHERWISE NOTED. THEY ARE SHOWN ON THE PAGE WITH THE INTEGRATED CIRCUITS THEY SHOULD BE PLACED NEAR.
5. NHET1xx means NHET1_[xx].
6. OBSERVE THE LAYOUT NOTES IN SCHEMATIC.

Changes on RevC:

1. Changed SD card slot
2. R291 and R293 value for Gladiator 1.2V core power
3. Route EMIF D[8:15] to exp connector (missed on RevB)

Changes on RevD:

1. Added n_channel FET and RC to JTAG nTRST (P07)

Changes on RevE:

1. Added n_channel FET and RC to JTAG nTRST (P07)

SCHEMATIC CONTENTS

- 01 TITLE SHEET
- 02 MCU ADC
- 03 MCU EMIF
- 04 MCU SPI
- 05 MCU ETM
- 06 MCU DCAN, FLEXRAY, and LIN
- 07 MCU JTAG and OSC
- 08 MCU NHET
- 09 MCU GPIO
- 10 MCU Power & GND
- 11 FETSwitches for 1st USB
- 12 EMIF Addr/ETM/RTP
- 13 SDRAM
- 14 Sensors, LEDs, and Pushbutton
- 15 FET Switches for 2nd USB
- 16 USB 1st OHCI Host
- 17 USB device and 2nd OHCI Host
- 18 FET Switch for RMII and DIP Switch
- 19 Ethernet PHY & Connector
- 20 CAN Transceivers
- 21 JTAG and MIPI ETM Connector
- 22 DMM and RTP Mictor Connectors
- 23 XD100V2 FTDI2232
- 24 XDS100V2 CPLD
- 25 RESET
- 26 Power Supply
- 27 Power Inut
- 28 EXP P1 and EXP P2
- 29 EXP P3

Texas Instruments Inc		
Title		
RM57 HDK		
Size	Document Number	Rev
A	TITLE	B
Date:	Tuesday, May 20, 2014	Sheet 1 of 29

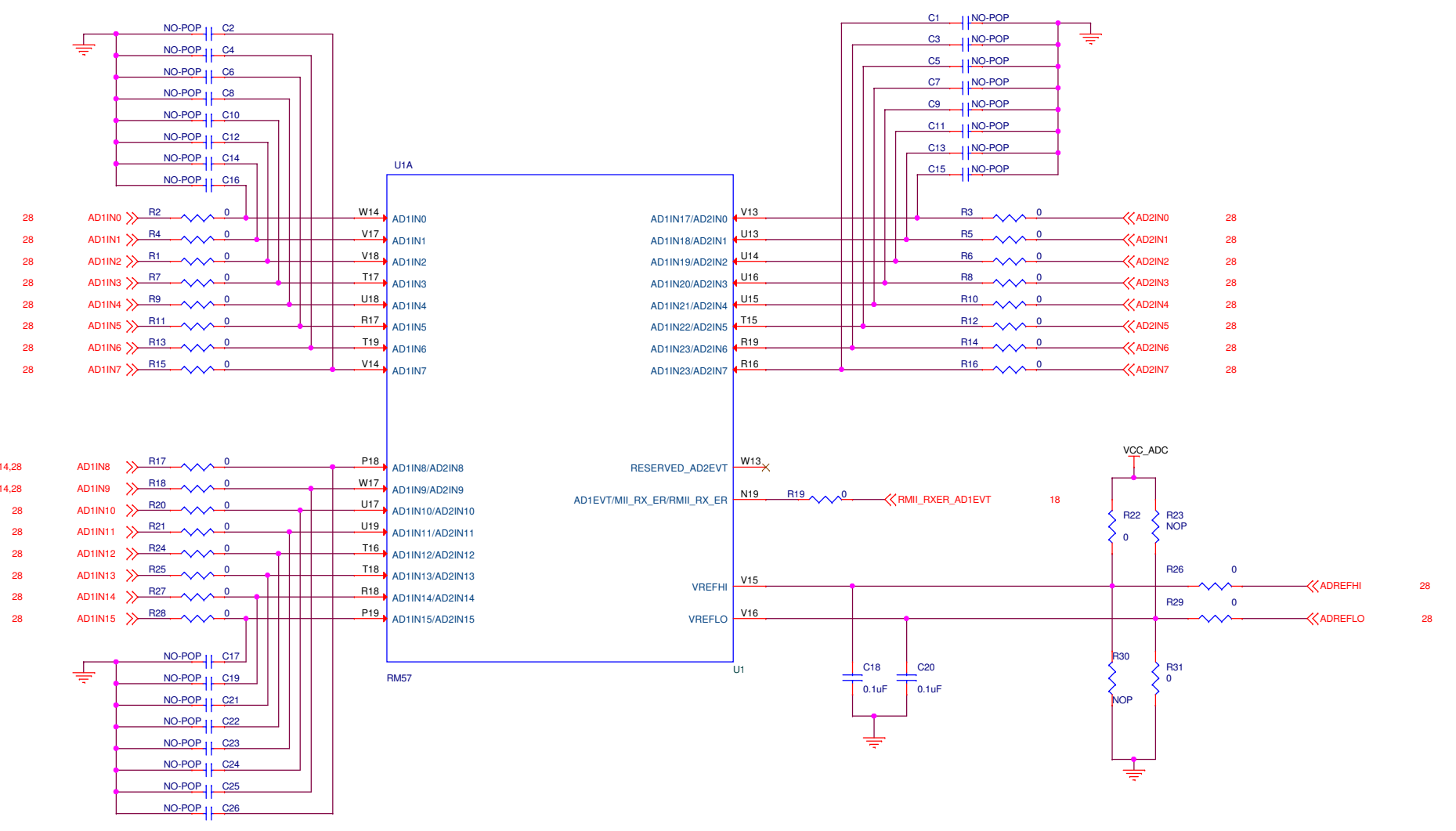

Title			RM57 HDK
Size	Document	Number	Rev
B	MCU ADC		B
Date:	Tuesday, May 20, 2014	Sheet	2 of 29

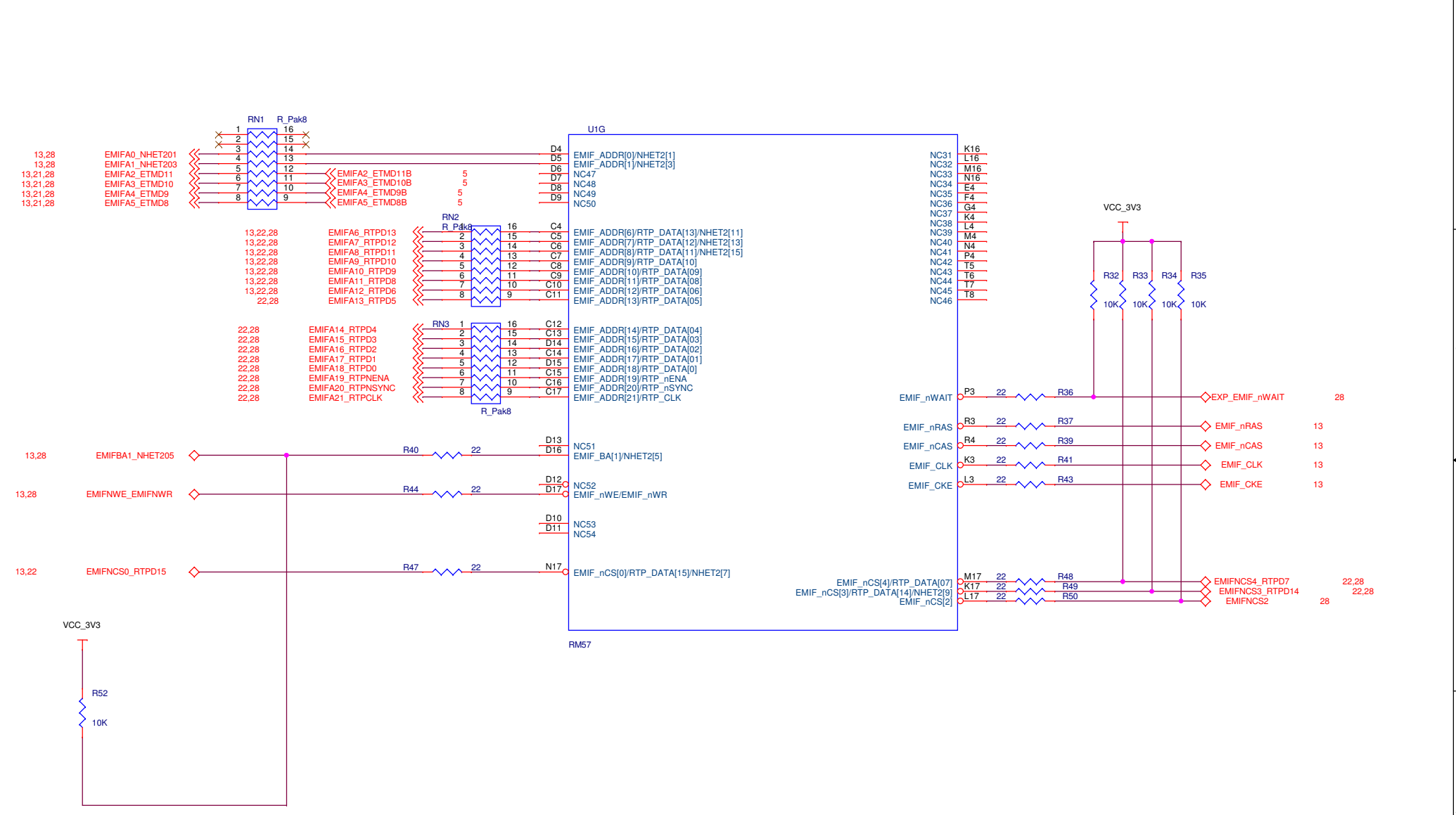

Title		
RM57 HDK		
Size	Document Number	Rev
B	MCU EMIF	B
Date:	Tuesday, May 20, 2014	Sheet 3 of 29

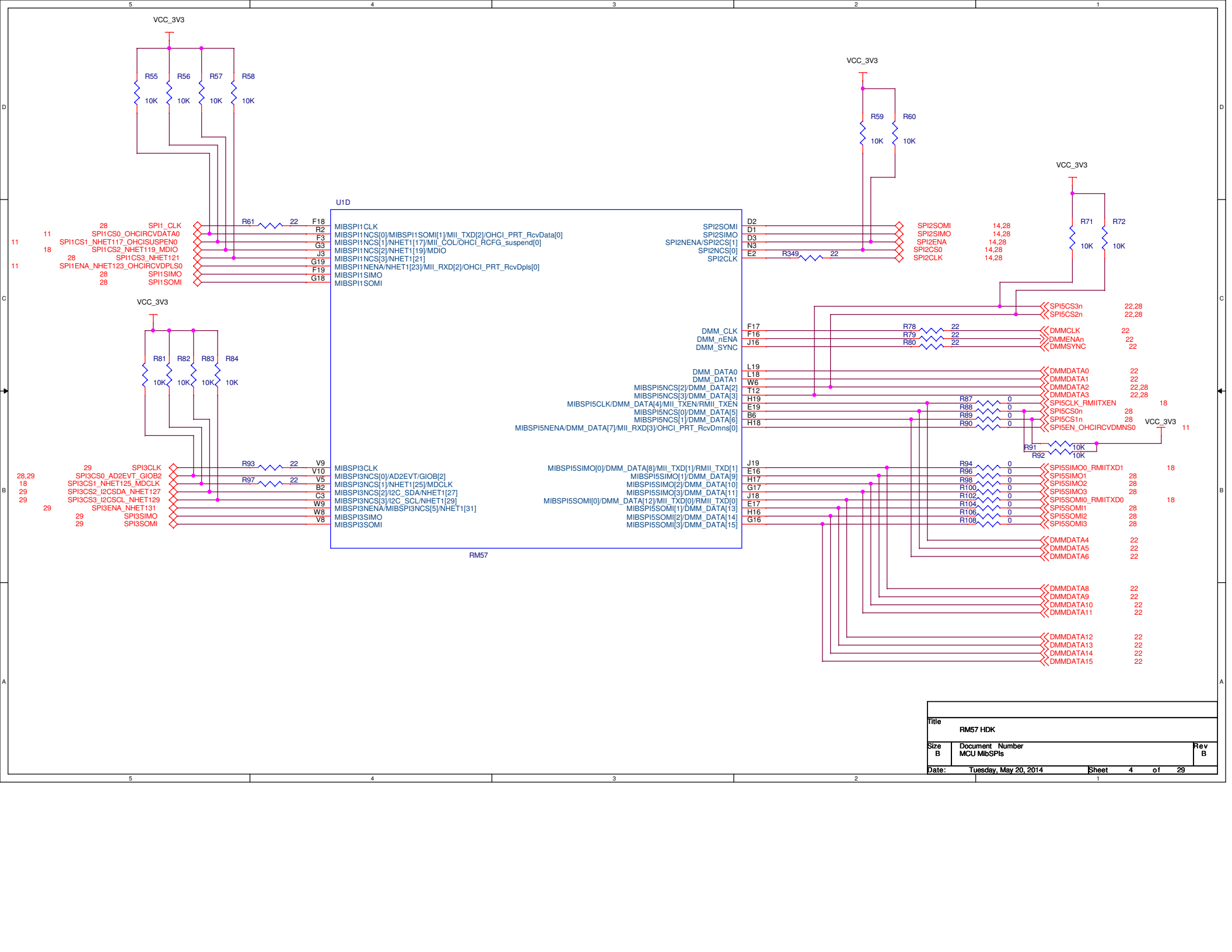

Title		
RM57 HDK		
Size B	Document Number	Rev B
	MCU MibSPis	
Date:	Tuesday, May 20, 2014	Sheet 4 of 29

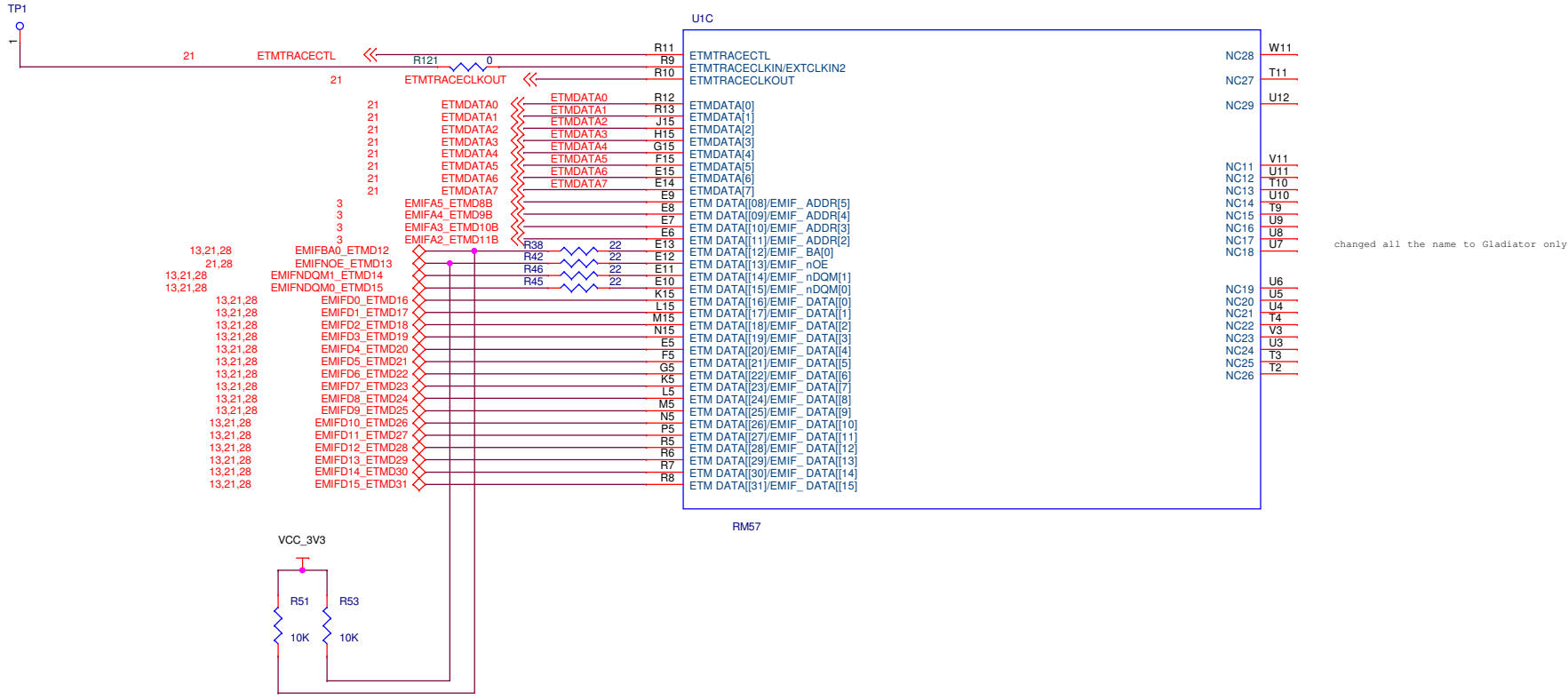

changed all the name to Gladiator only

Title		
RM57 HDK		
Size	Document Number	Rev
B	MCU ETM & Rsvd RTP	B
Date:	Tuesday, May 20, 2014	Sheet 5 of 29

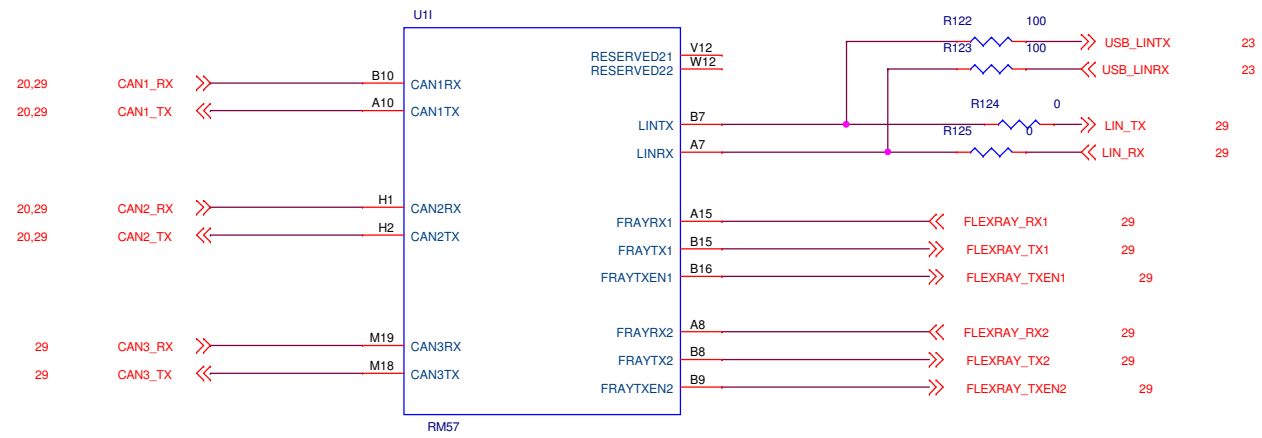

Title		
RM57 HDK		
Size	Document Number	Rev
B	MCU DCAN, FRAY, LIN	D
Date:	Tuesday, May 20, 2014	Sheet 6 of 29

To MCU
18
19
TO PHY

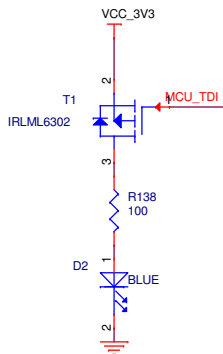
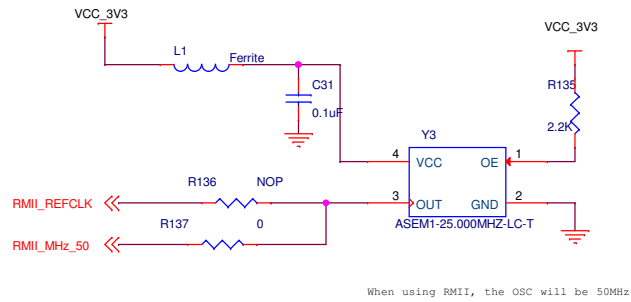

place R225, R226,
R132, and C29 close to
U1

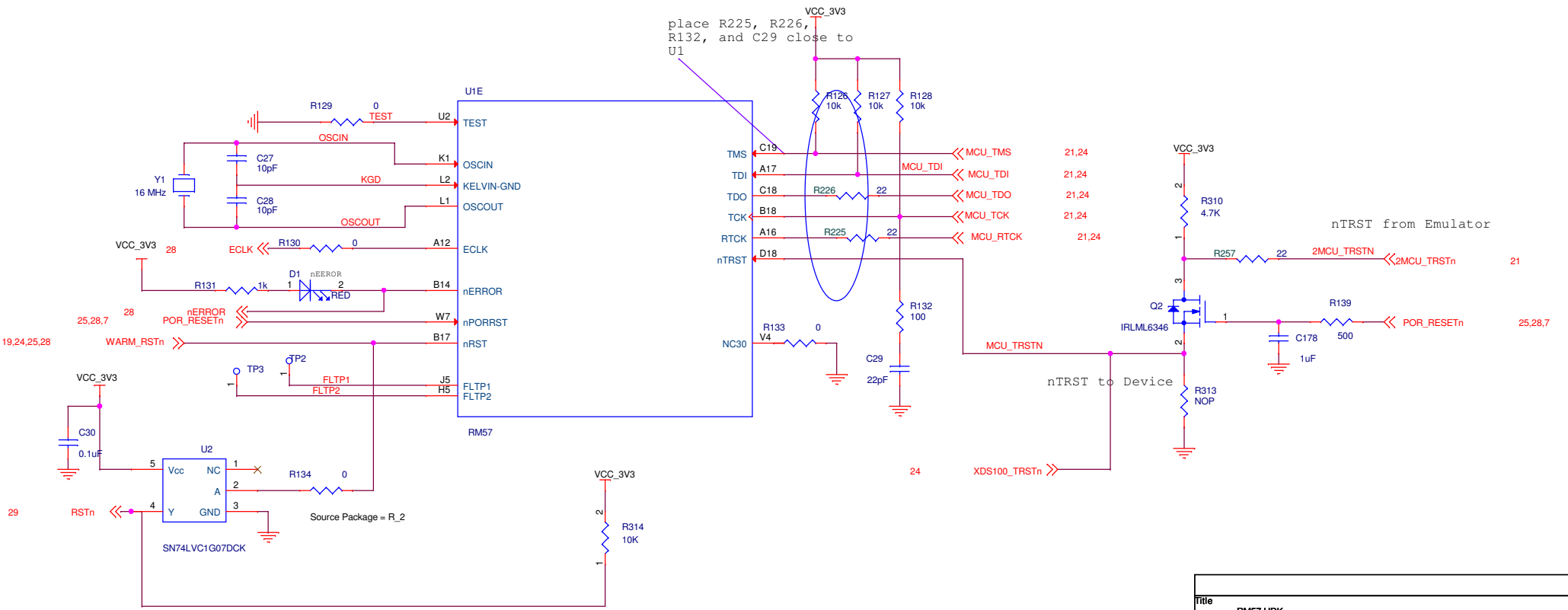

Title		RM57 HDK	
Size	Document Number	MCU JTAG & OSC	
Date:	Tuesday, May 20, 2014	Sheet	7 of 29
			Rev D



Title		
RM57 HDK		
Size B	Document Number	Rev B
	MCU NHET	
Date:	Tuesday, May 20, 2014	Sheet 8 of 29

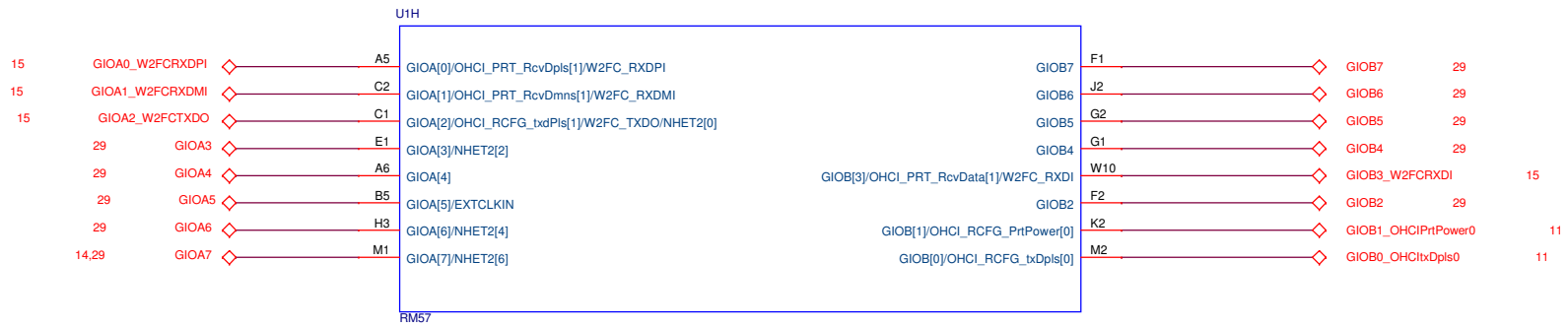

Title		
RM57 HDK		
Size B	Document Number	Rev B
	MCU GPIO	
Date:	Tuesday, May 20, 2014	Sheet 9 of 29

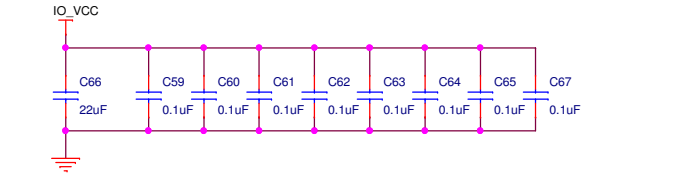
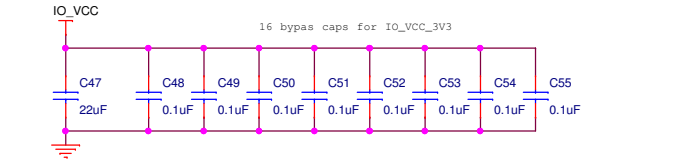
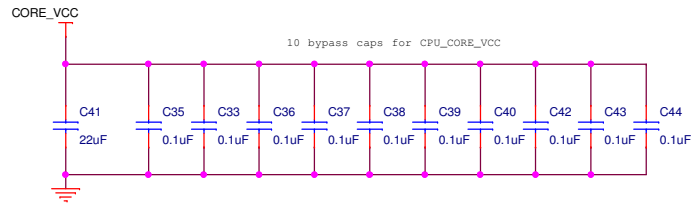
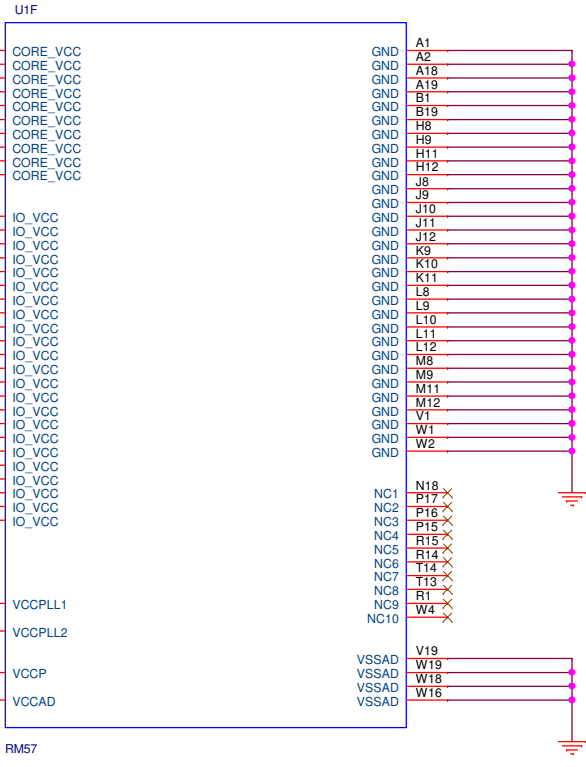
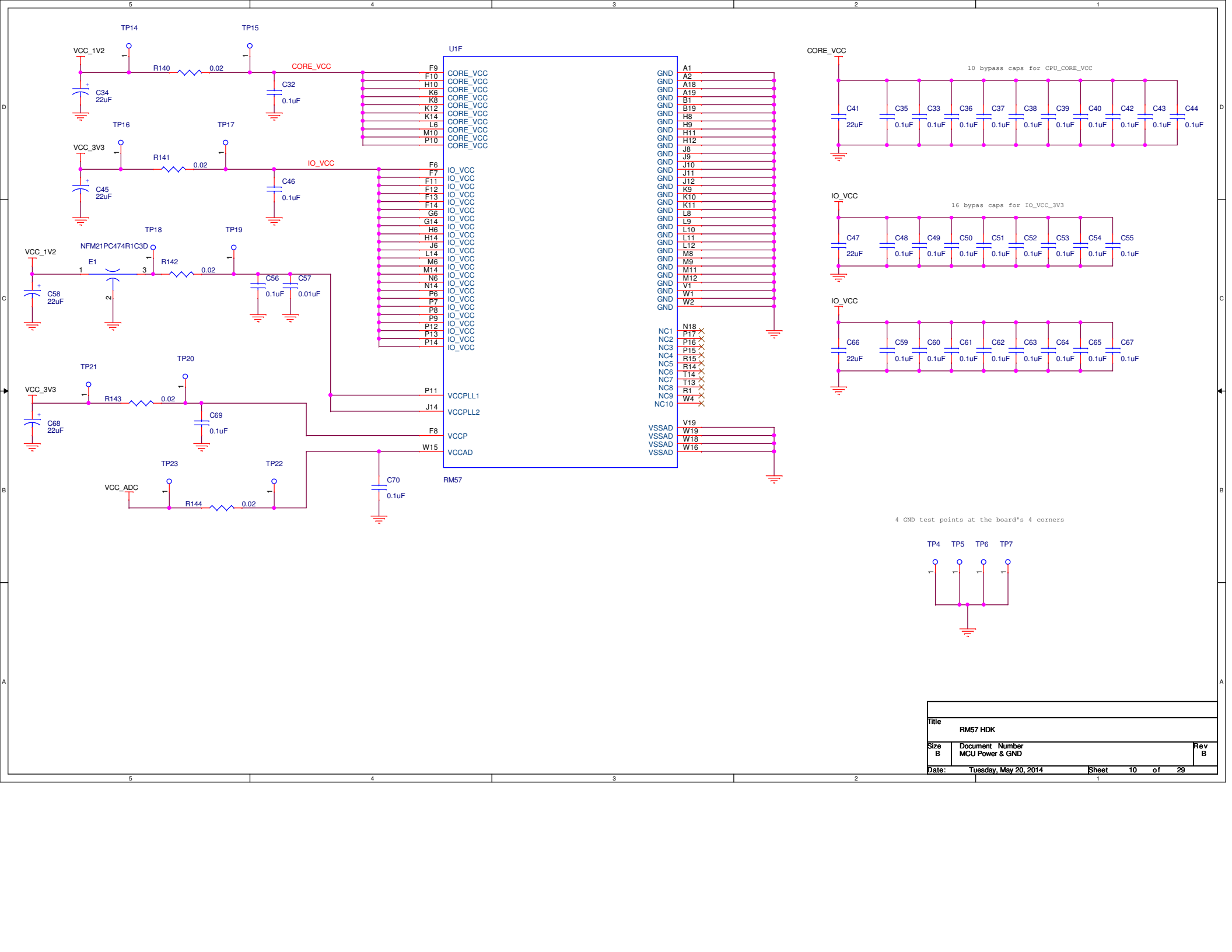

4 GND test points at the board's 4 corners

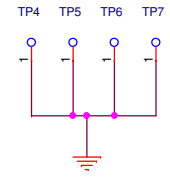

Title		
RM57 HDK		
Size	Document Number	Rev
B	MCU Power & GND	B
Date:	Tuesday, May 20, 2014	Sheet 10 of 29

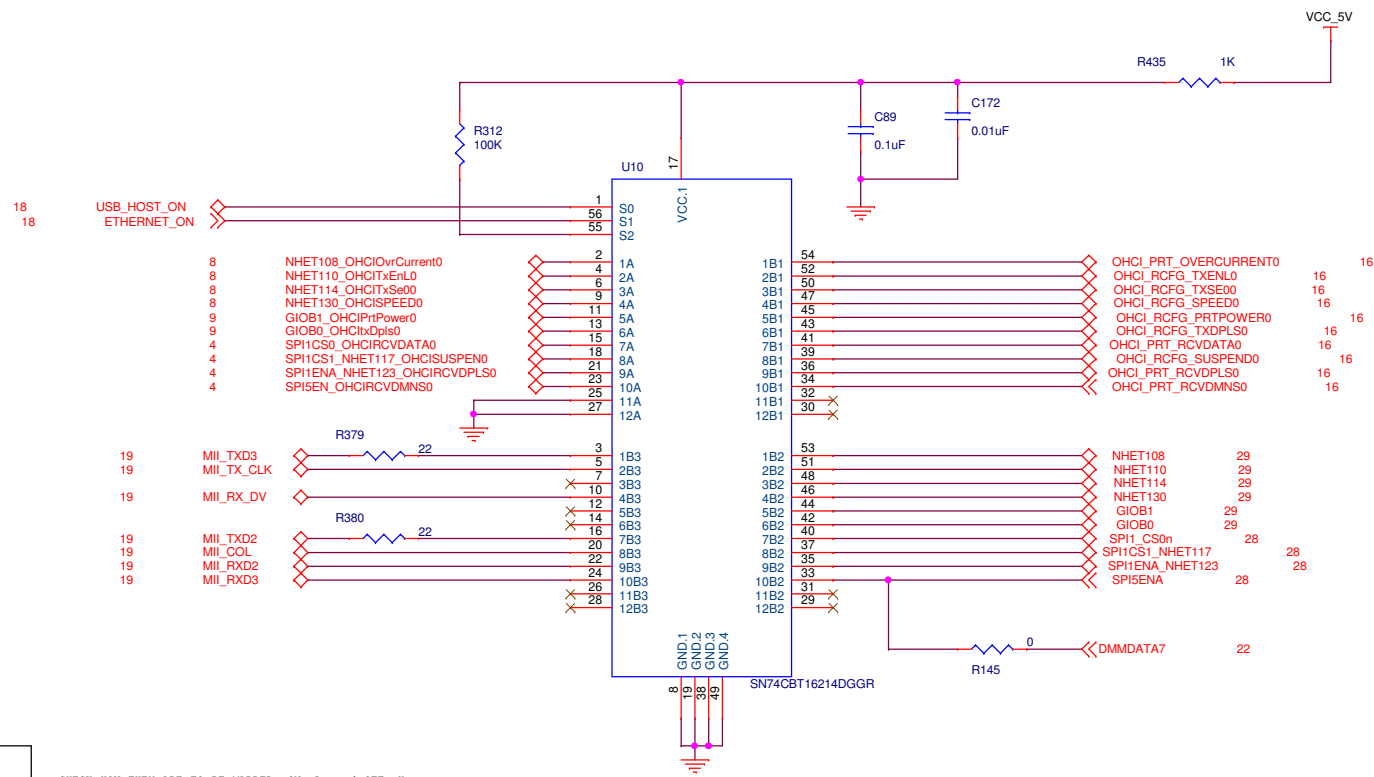

S2	S1	S0	A
1	0	0	Z
1	0	1	B3**
1	1	0	B1 **
1	1	1	B2 **

CHECK HOW THEY ARE TO BE MAPPED. ON--L, and OFF--H

Title		
TMS570LS3x/RM5x CPU CARD		
Size	Document Number	Rev
B	FET SWs FOR 1st USB HOST	B
Date:	Tuesday, May 20, 2014	Sheet 11 of 29

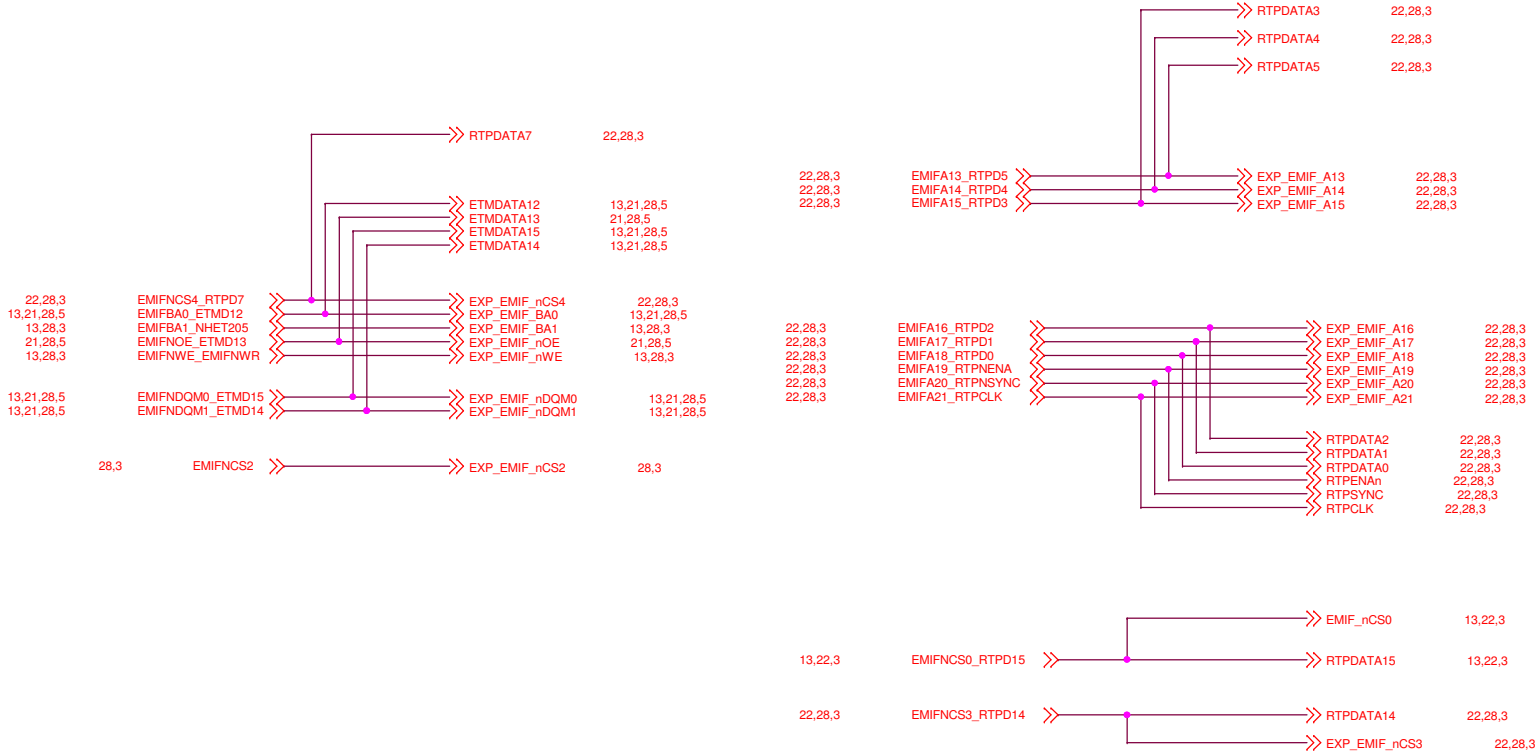

Title			
RM57 HDK			
Size	Document	Number	Rev
B	EMIF DATA and ADDR BUSES		B
Date:	Tuesday, May 20, 2014	Sheet	12 of 29

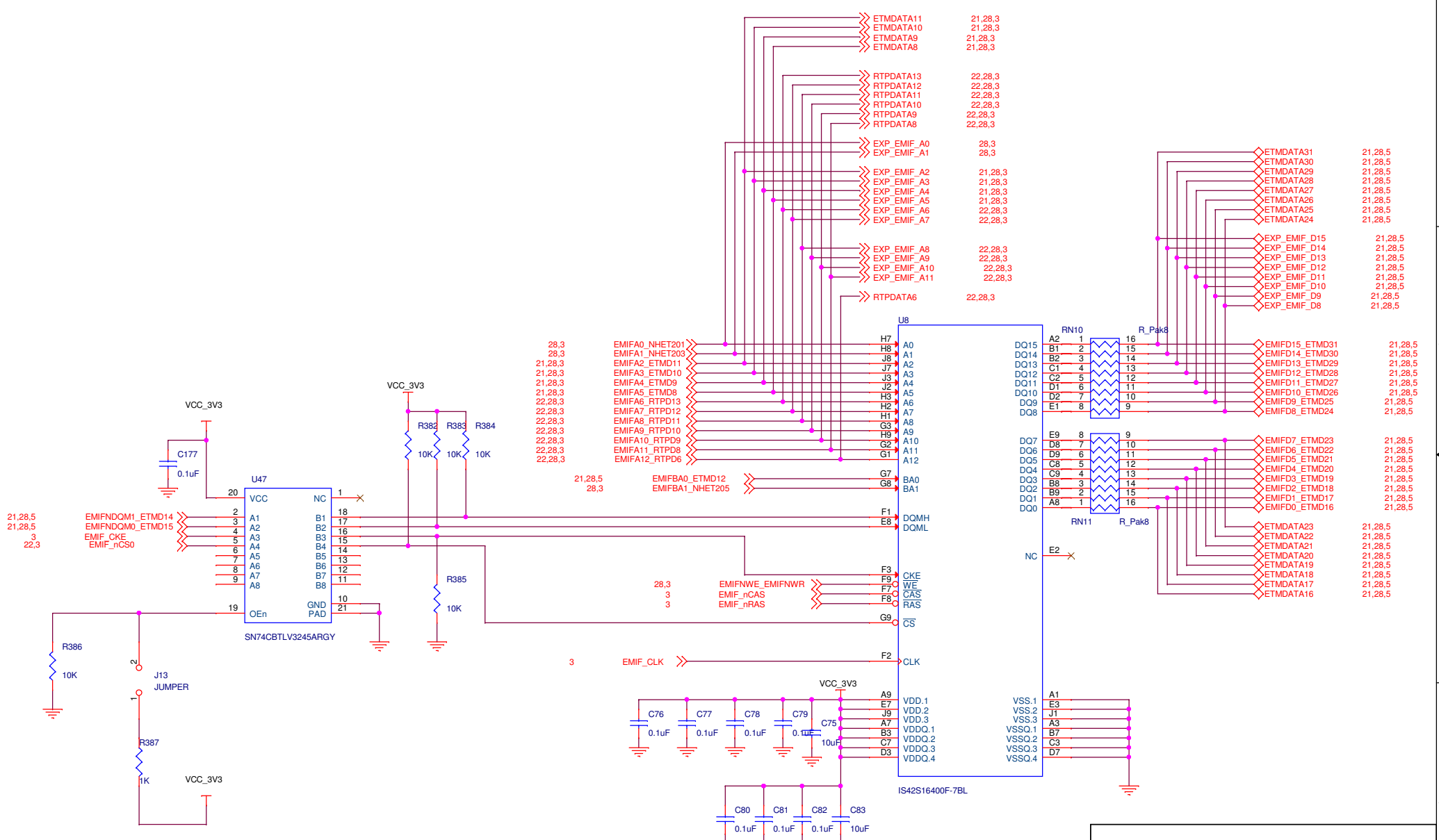

21,28,5
21,28,5
3
22,3

EMIFNDQM1_ETMD14
EMIFNDQM0_ETMD15
EMIF_CKE
EMIF_nCS0

VCC_3V3
C177
0.1uF

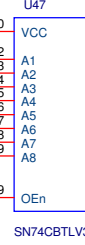

SN74CBTLV3245ARGY

VCC_3V3



J13
JUMPER

R387
1K

VCC_3V3

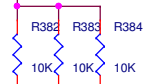

R382
10K
R383
10K
R384
10K

VCC_3V3



R385
10K

28,3
28,3
21,28,3
21,28,3
21,28,3
21,28,3
22,28,3
22,28,3
22,28,3
22,28,3
22,28,3
22,28,3
22,28,3

EMIFA0_NHET201
EMIFA1_NHET203
EMIFA2_ETMD11
EMIFA3_ETMD10
EMIFA4_ETMD9
EMIFA5_ETMD8
EMIFA6_RTPD13
EMIFA7_RTPD12
EMIFA8_RTPD11
EMIFA9_RTPD10
EMIFA10_RTPD9
EMIFA11_RTPD8
EMIFA12_RTPD6

21,28,5
28,3

EMIFBA0_ETMD12
EMIFBA1_NHET205

28,3
3
3

EMIFNWE_EMIFNWR
EMIF_nCAS
EMIF_nRAS



C76
0.1uF
C77
0.1uF
C78
0.1uF



C79
0.1uF
C75
10uF

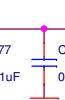

C80
0.1uF
C81
0.1uF
C82
0.1uF

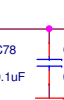

C83
10uF

VCC_3V3
A9
E7
J9
A7
B3
C7
D3

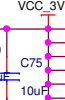

IS42S16400F-7BL

VSS.1
VSS.2
VSS.3
VSSQ.1
VSSQ.2
VSSQ.3
VSSQ.4

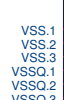

A1
E3
J1
A3
B7
C3
D7

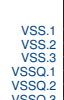

IS42S16400F-7BL

U8

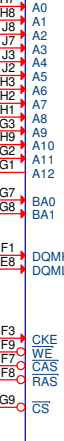

A0
A1
A2
A3
A4
A5
A6
A7
A8
A9
A10
A11
A12
BA0
BA1
DQMH
DQML
F1
E8
F3
F4
F5
F6
F7
F8
F9
G9
CS
F2
CLK

ETMDATA11 21,28,3
ETMDATA10 21,28,3
ETMDATA9 21,28,3
ETMDATA8 21,28,3
RTPDATA13 22,28,3
RTPDATA12 22,28,3
RTPDATA11 22,28,3
RTPDATA10 22,28,3
RTPDATA9 22,28,3
RTPDATA8 22,28,3
EXP_EMIF_A0 28,3
EXP_EMIF_A1 28,3
EXP_EMIF_A2 21,28,3
EXP_EMIF_A3 21,28,3
EXP_EMIF_A4 21,28,3
EXP_EMIF_A5 21,28,3
EXP_EMIF_A6 22,28,3
EXP_EMIF_A7 22,28,3
EXP_EMIF_A8 22,28,3
EXP_EMIF_A9 22,28,3
EXP_EMIF_A10 22,28,3
EXP_EMIF_A11 22,28,3
RTPDATA6 22,28,3

EMIFD15_ETMD31
EMIFD14_ETMD30
EMIFD13_ETMD29
EMIFD12_ETMD28
EMIFD11_ETMD27
EMIFD10_ETMD26
EMIFD9_ETMD25
EMIFD8_ETMD24



EMIFD15_ETMD31 21,28,5
EMIFD14_ETMD30 21,28,5
EMIFD13_ETMD29 21,28,5
EMIFD12_ETMD28 21,28,5
EMIFD11_ETMD27 21,28,5
EMIFD10_ETMD26 21,28,5
EMIFD9_ETMD25 21,28,5
EMIFD8_ETMD24 21,28,5

EMIFD7_ETMD23
EMIFD6_ETMD22
EMIFD5_ETMD21
EMIFD4_ETMD20
EMIFD3_ETMD19
EMIFD2_ETMD18
EMIFD1_ETMD17
EMIFD0_ETMD16



EMIFD7_ETMD23 21,28,5
EMIFD6_ETMD22 21,28,5
EMIFD5_ETMD21 21,28,5
EMIFD4_ETMD20 21,28,5
EMIFD3_ETMD19 21,28,5
EMIFD2_ETMD18 21,28,5
EMIFD1_ETMD17 21,28,5
EMIFD0_ETMD16 21,28,5

Title		
RM57 HDK		
Size	Document Number	Rev
B	SDRAM	B
Date:	Tuesday, May 20, 2014	Sheet 13 of 29

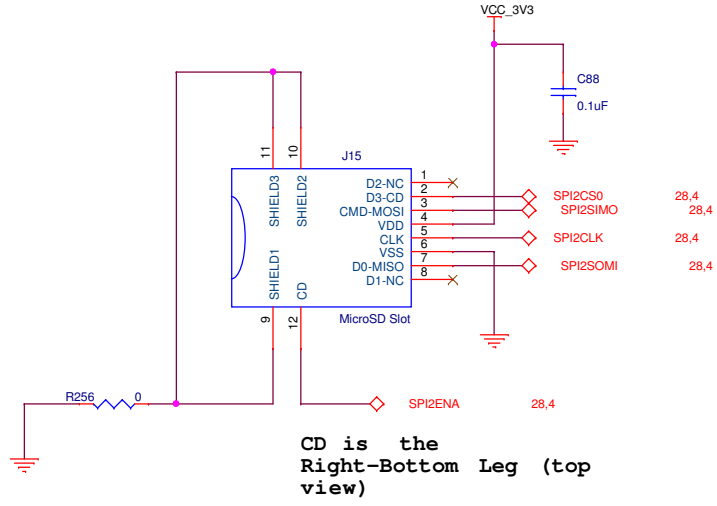
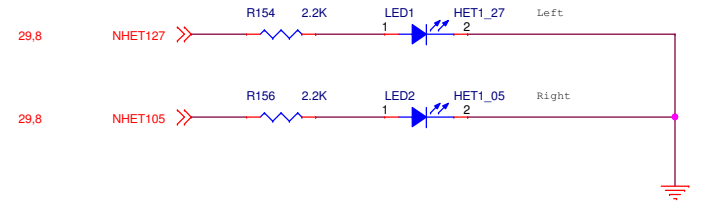
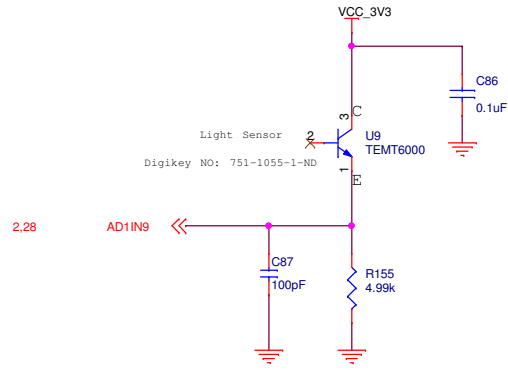
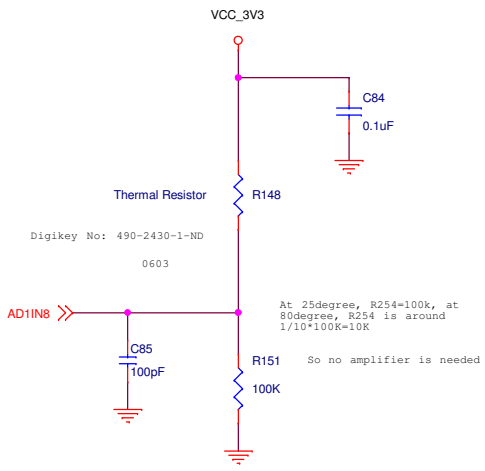

CD is the Right-Bottom Leg (top view)

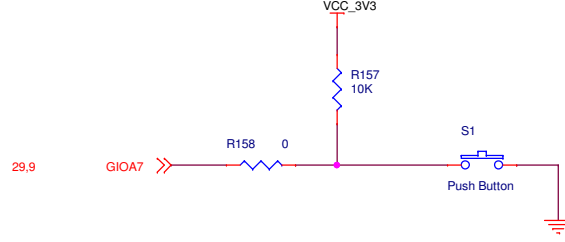

Title		
RM57 HDK		
Size	Document Number	Rev
B	SENSOR, LED, PB	C
Date:	Tuesday, May 20, 2014	Sheet 14 of 29

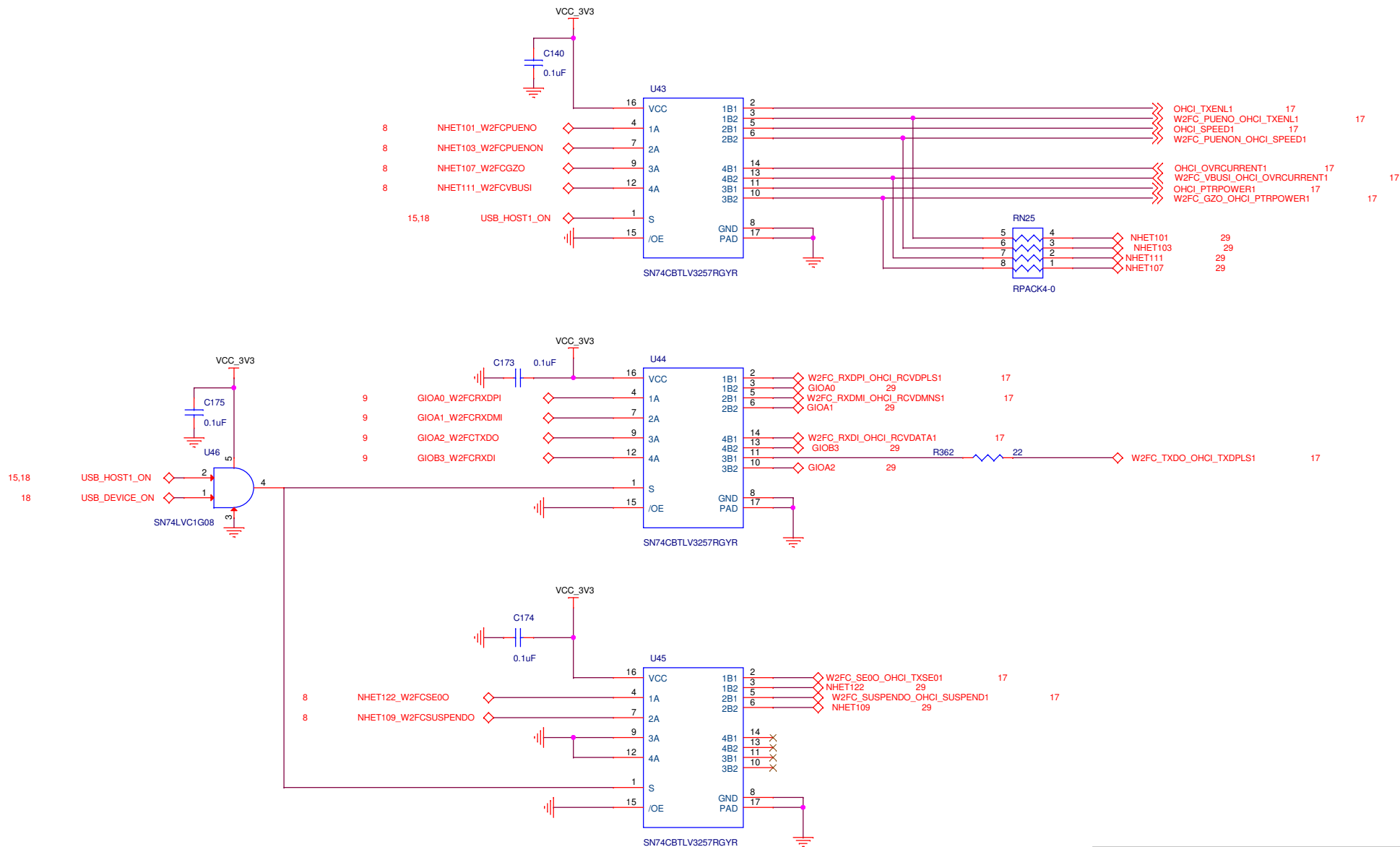

Title		
RM57 HDK		
Size	Document Number	Rev
B	FET SWs FOR USB DEVICE & 2nd HOST	B
Date:	Tuesday, May 20, 2014	Sheet 15 of 29

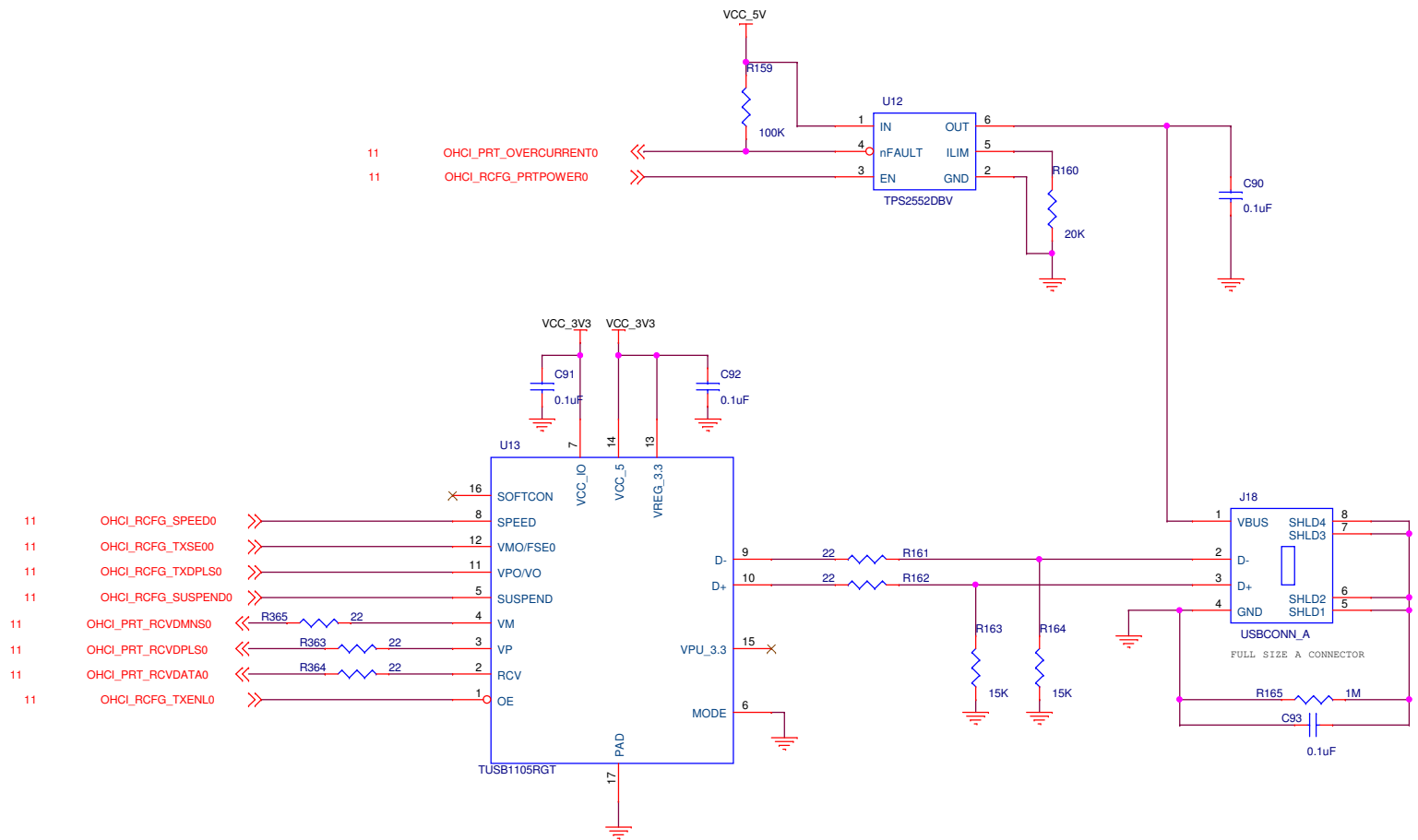

Title		
RM57 HDK		
Size	Document Number	Rev
B	USB 1st OHCI Host	B
Date:	Tuesday, May 20, 2014	Sheet 16 of 29

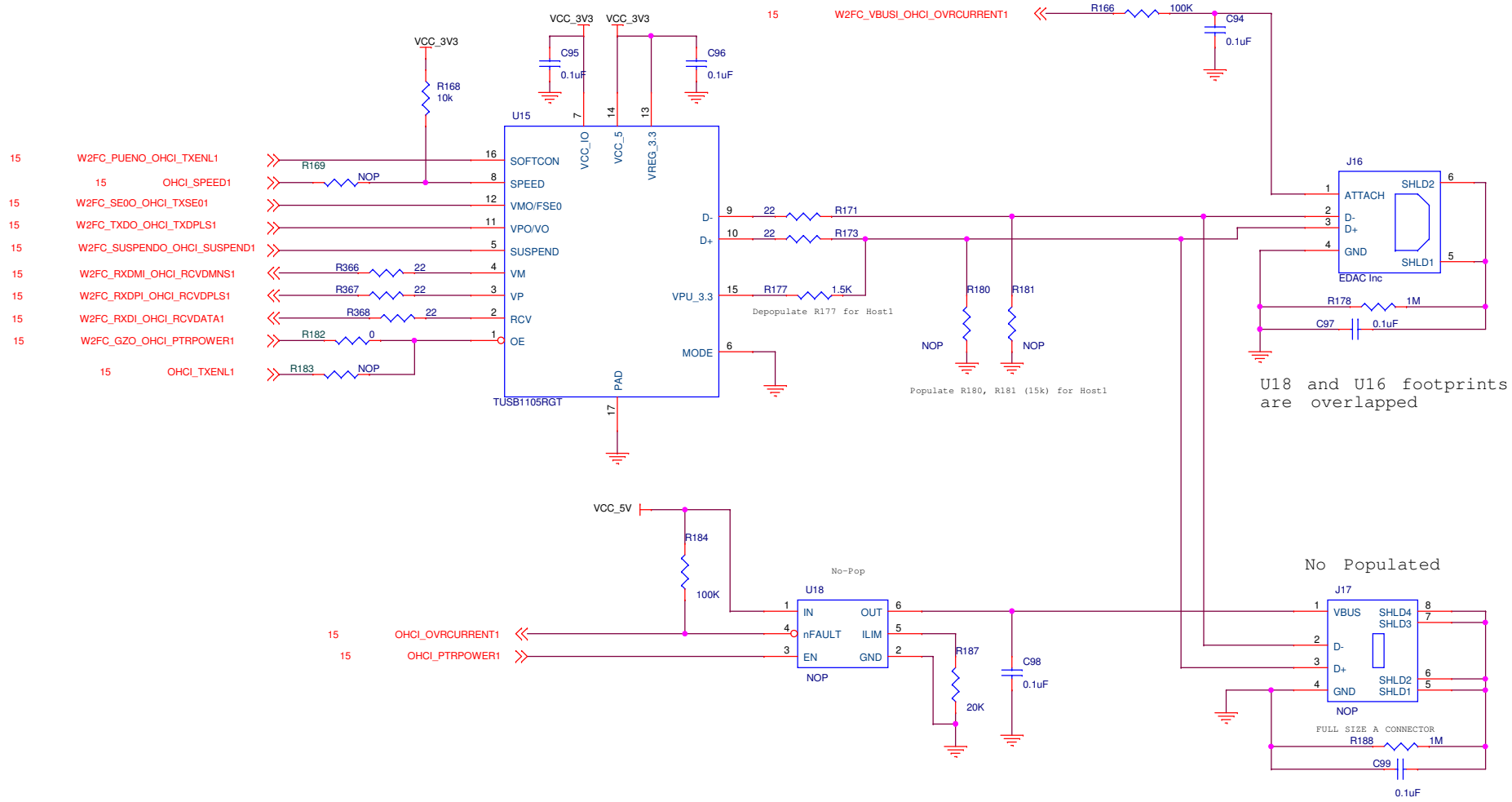

U18 and U16 footprints are overlapped

No Populated

Title		RM57 HDK	
Size B	Document Number	USB Device & 2nd HOST	
Date:	Tuesday, May 20, 2014	Sheet	17 of 29

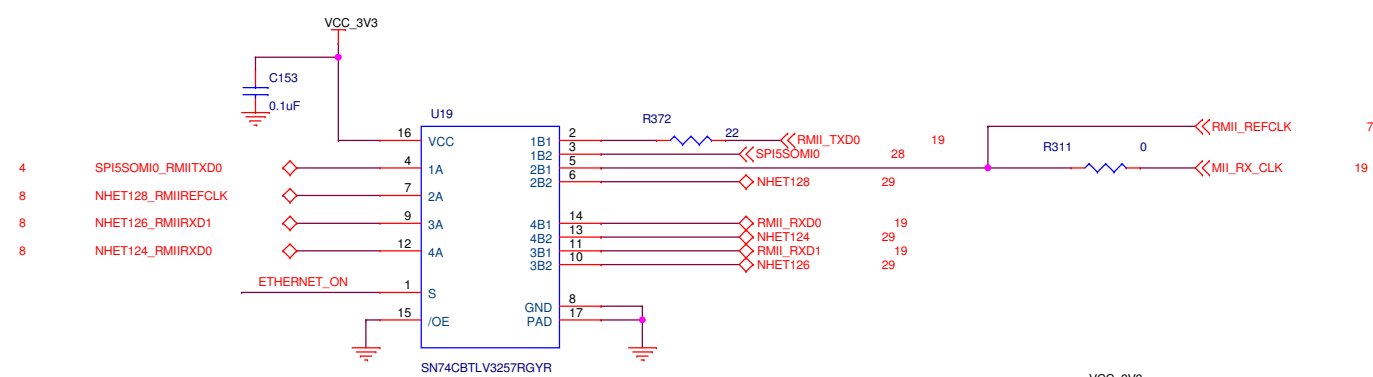
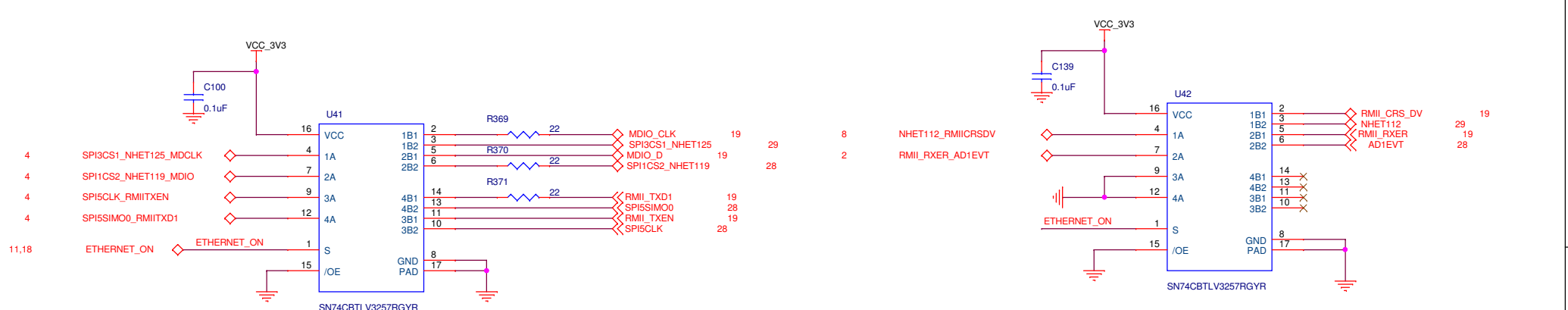

Silkscreen for Dip switch

USB HOST1 ON
 USB Host2 ON
 USB Device ON
 Ethernet ON

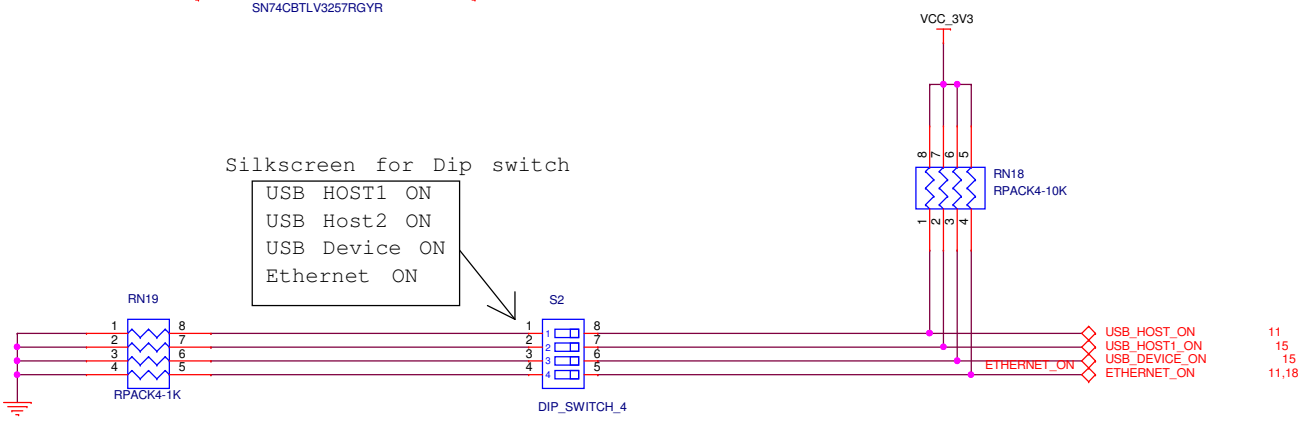

S	A
0	B1
1	B2

Title		RM57 HDK	
Size B	Document Number	FET SW 4 RMII & DIP SW	
Date:	Tuesday, May 20, 2014	Sheet	18 of 29

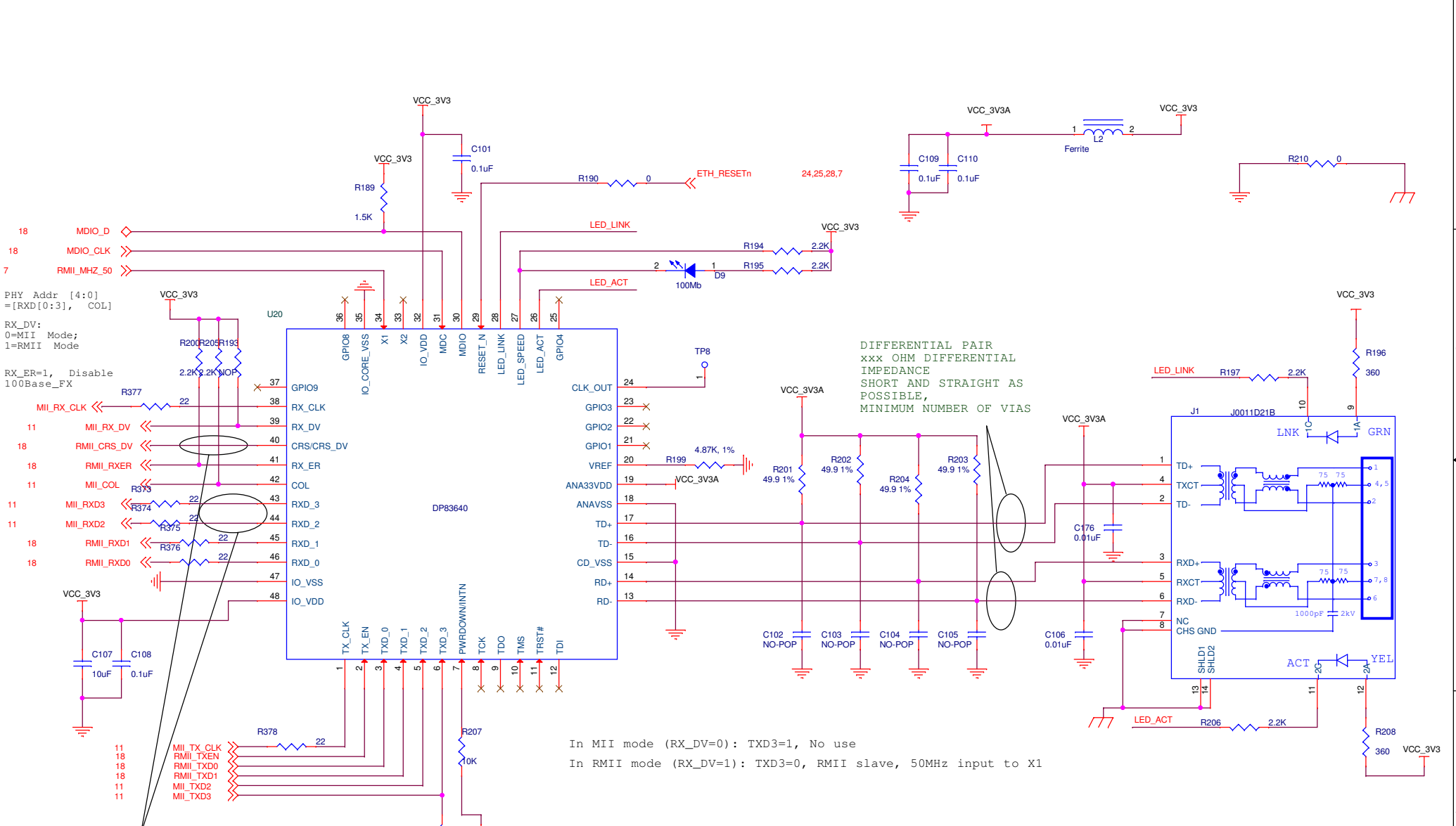

DIFFERENTIAL PAIR
 xxx OHM DIFFERENTIAL
 IMPEDANCE
 SHORT AND STRAIGHT AS
 POSSIBLE,
 MINIMUM NUMBER OF VIAS

In MII mode (RX_DV=0): TXD3=1, No use
 In RMI mode (RX_DV=1): TXD3=0, RMI slave, 50MHz input to X1

- Strongly Recommend:**
1. Add a 2.2K ohms pull-down resistors to RXD_2 and RXD_3 signals.
 2. Add a 2.2K ohms pull-up resistor to CRS/CRS_DV signal

Title		
RM57 HDK		
Size B	Document Number Ethernet PHY & Conn	Rev B
Date: Tuesday, May 20, 2014	Sheet 19	of 29

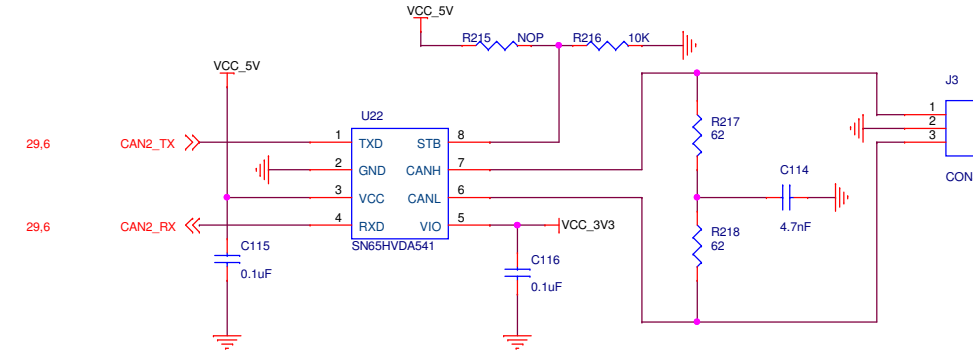
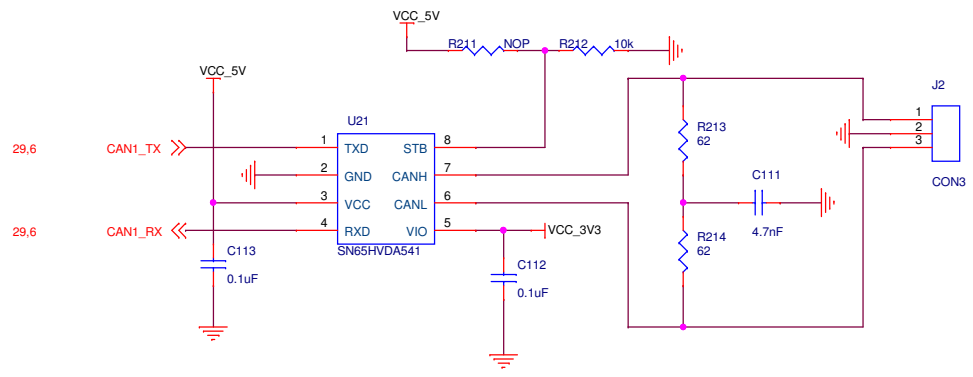

Title		
RM57 HDK		
Size	Document Number	Rev
B	DCAN Transceivers	B
Date:	Tuesday, May 20, 2014	Sheet 20 of 29
		1

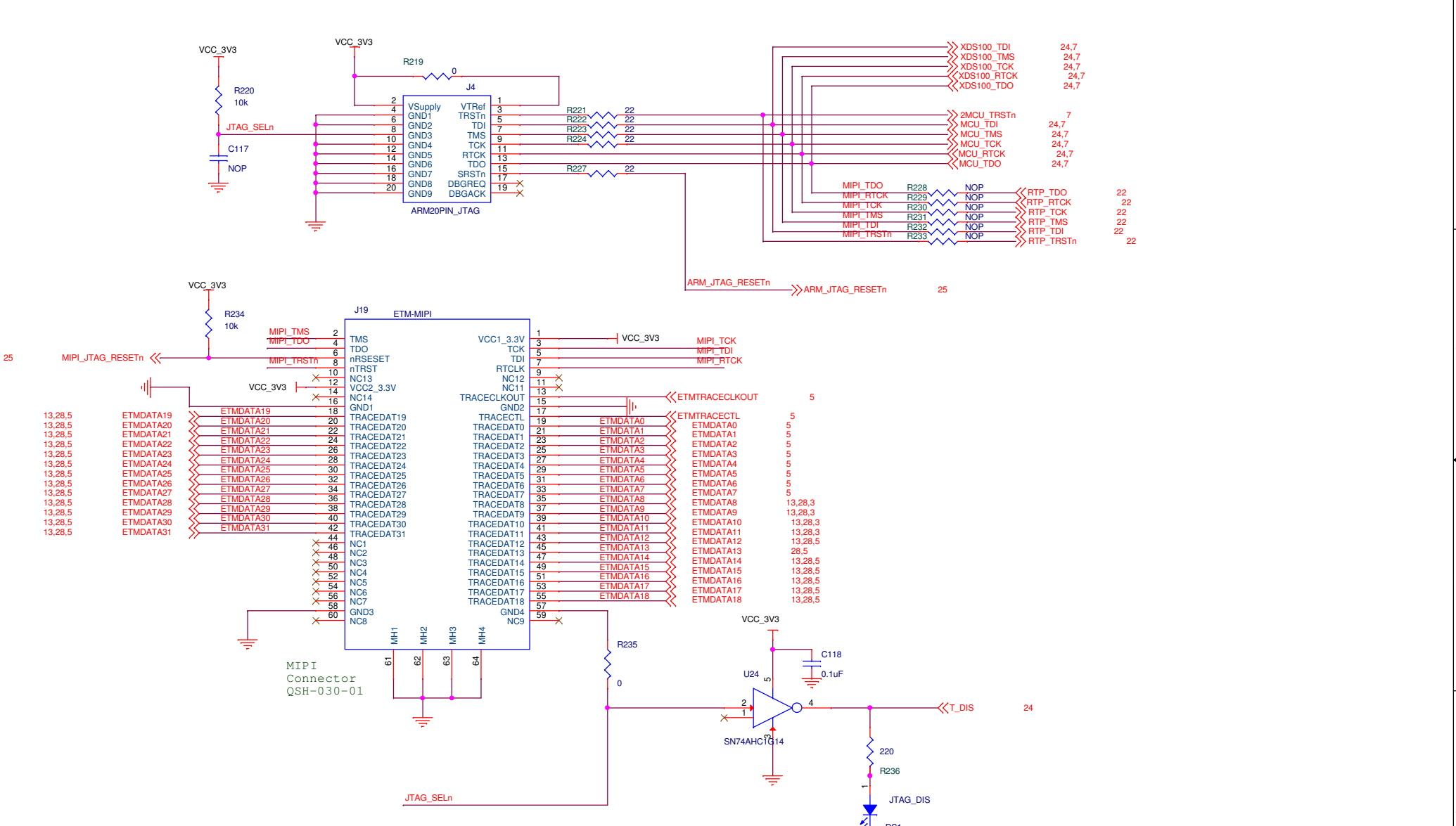

JTAG_SELn = HIGH --> XDS100
 JTAG_SELn = LOW --> ARM
 JTAG and MIPI

Title		
RM57 HDK		
Size B	Document Number	Rev B
JTAG & MIPI Connectors		
Date:	Tuesday, May 20, 2014	Sheet 21 of 29

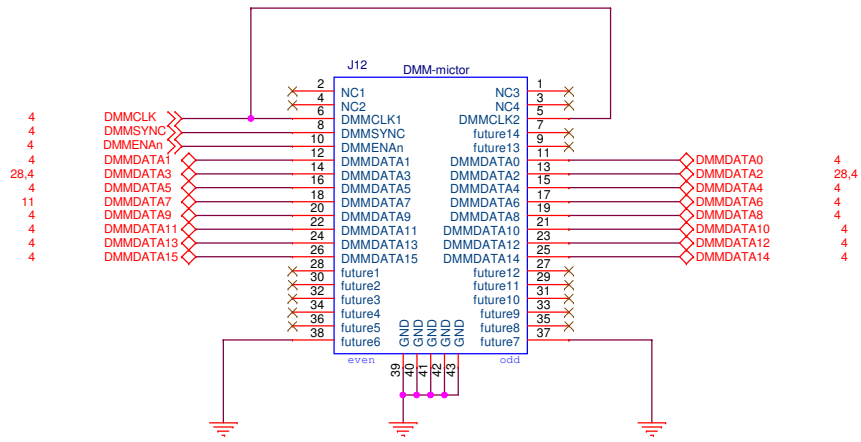

Foot Print Only
Pin39/40/41/42/43 are the central GND

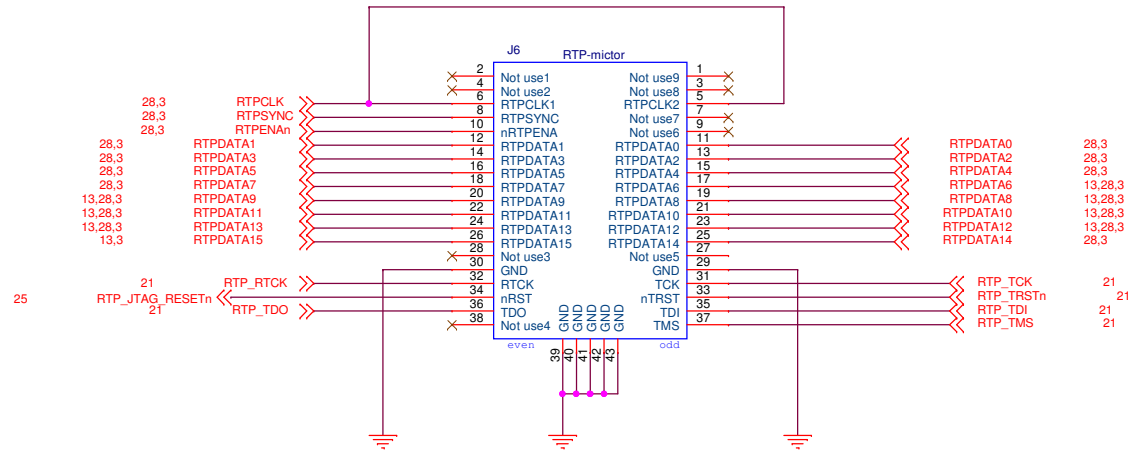

AMP 2-5767004-2
Receptacle, Center Strip Contacts
Foot Print Only

Title			
RM57 HDK			
Size	Document Number	Rev	
B	DMM and RTP Connectors	B	
Date:	Tuesday, May 20, 2014	Sheet	22 of 29

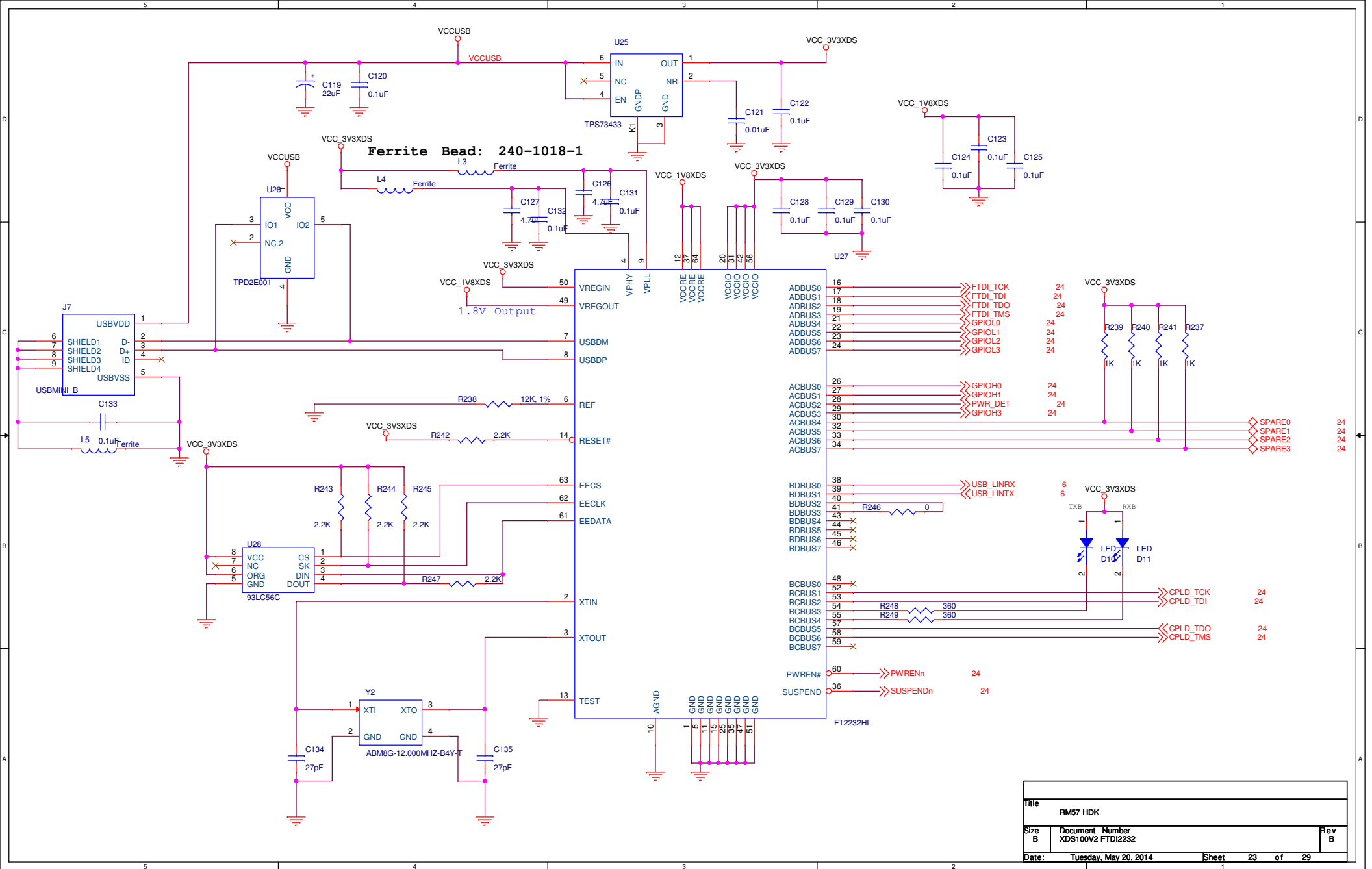

Title		
RM57 HDK		
Size	Document Number	Rev
B	XDS100V2 FTDI2232	B
Date:	Tuesday, May 20, 2014	Sheet 23 of 29

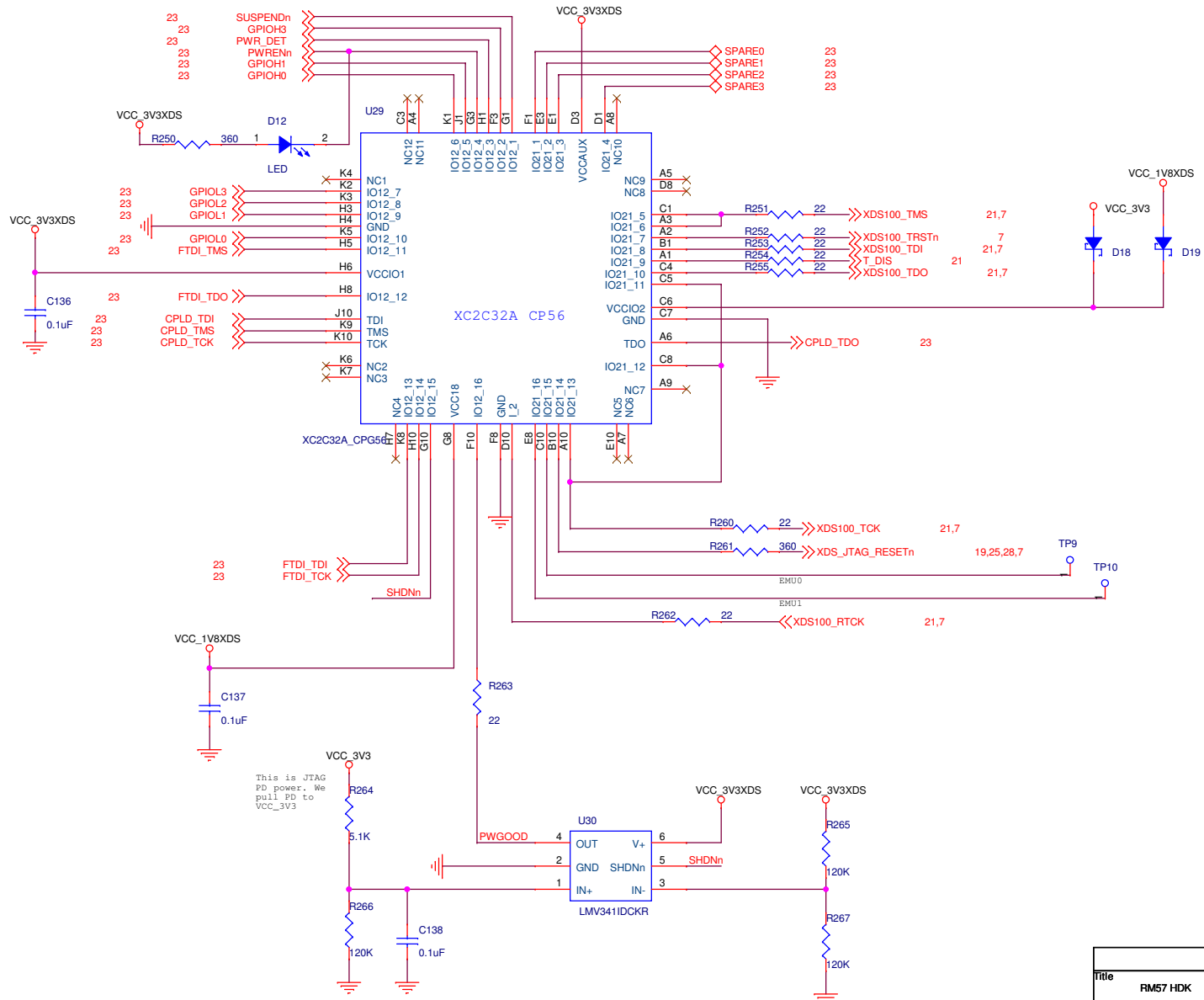

Title		
RM57 HDK		
Size	Document Number	Rev
B	XDS100V2 CPLD	B
Date:	Tuesday, May 20, 2014	Sheet 24 of 29



If VCC_3.3V below 3.0V --> RESET

This is the RESET pin rather than TRST

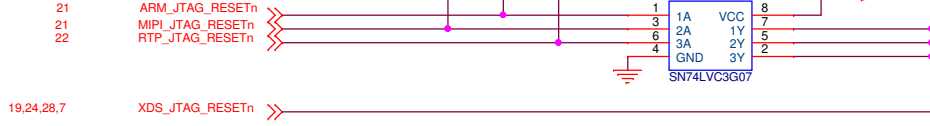

If VCC_3.3V below 3.0V --> RESET

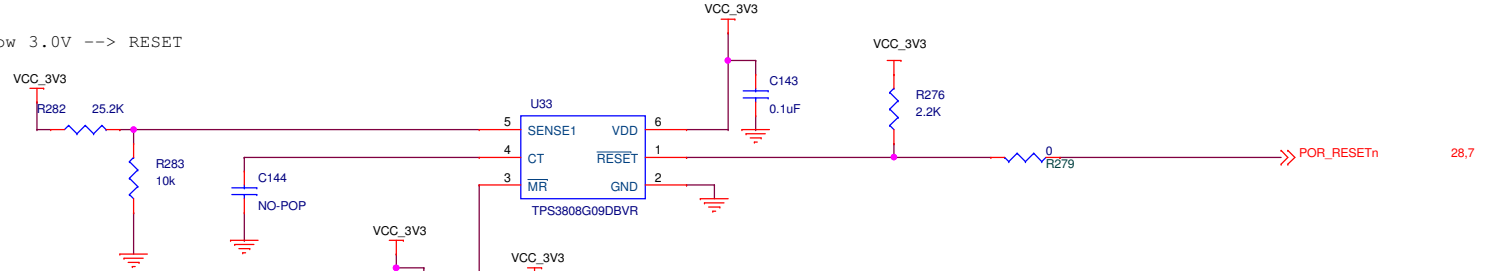

If VCC_1.5V below 1.35V --> RESET

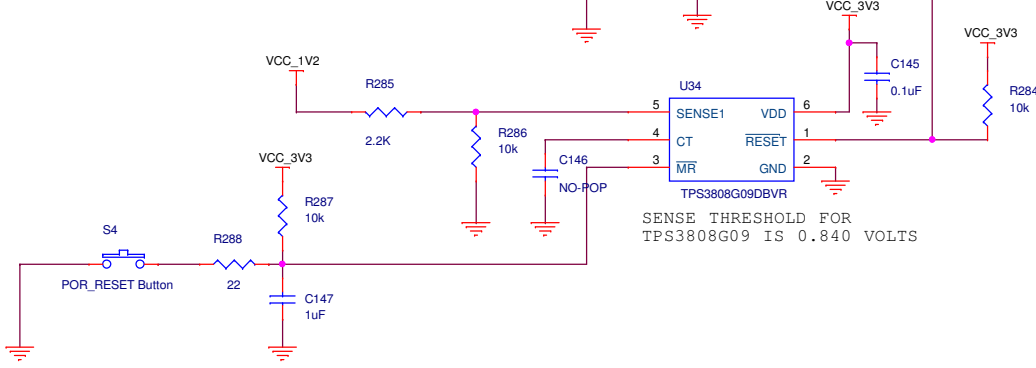

Title		
RM57 HDK		
Size B	Document Number	Rev B
RESET		
Date:	Tuesday, May 20, 2014	Sheet 25 of 29

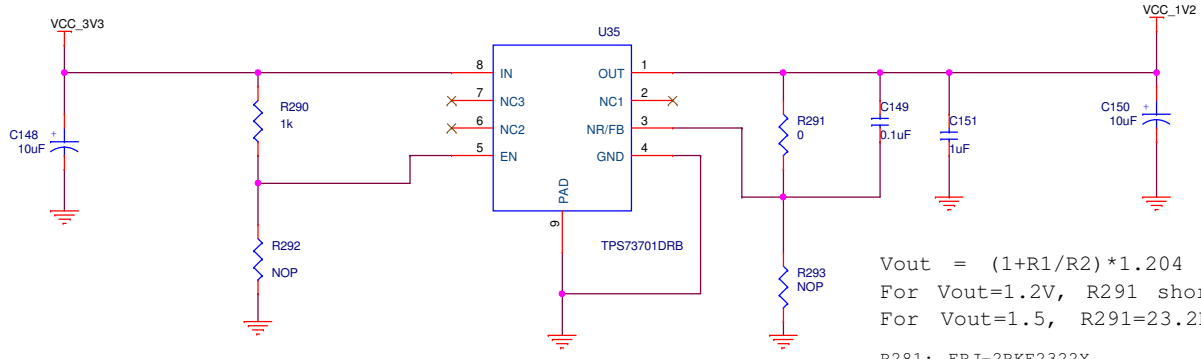

$V_{out} = (1 + R1/R2) * 1.204$
 For $V_{out} = 1.2V$, R291 shorted, and R293 Open
 For $V_{out} = 1.5$, R291 = 23.2Kohms, and R293 = 95.3Kohms
 R281: ERJ-2RKF2322X

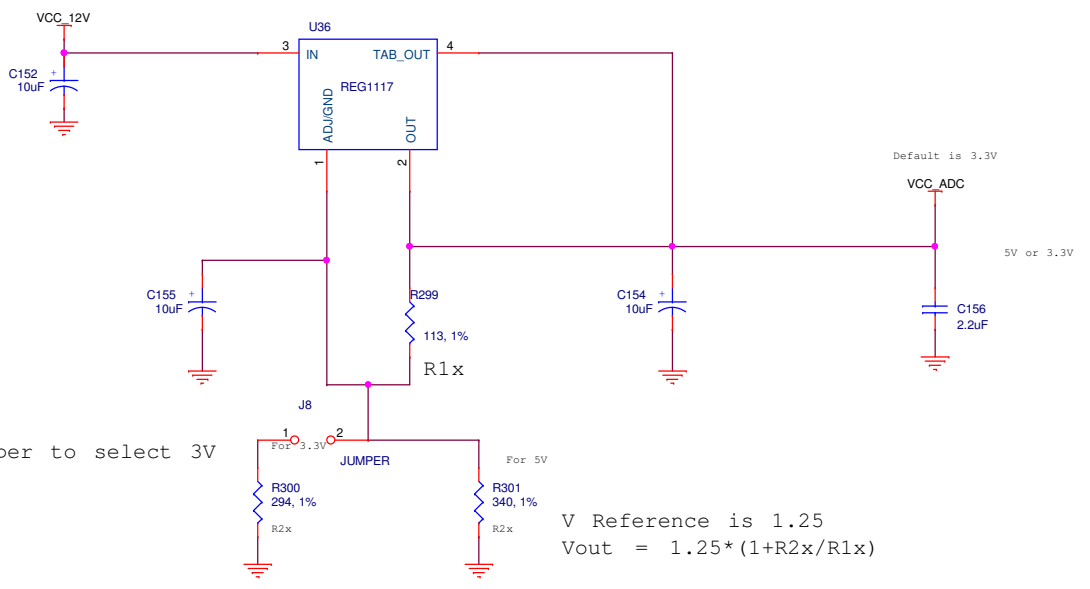
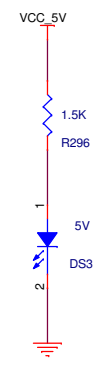
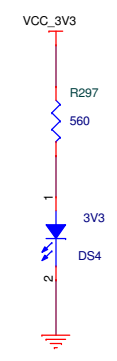
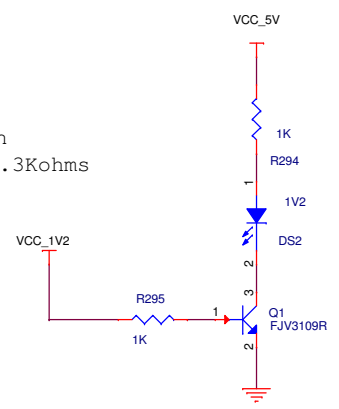

use jumper to select 3V

V Reference is 1.25
 $V_{out} = 1.25 * (1 + R2x/R1x)$

Title		
RM57 HDK		
Size B	Document Number	Rev C
Power Supply		
Date:	Tuesday, May 20, 2014	Sheet 26 of 29

+5V VOLTAGE REGULATOR

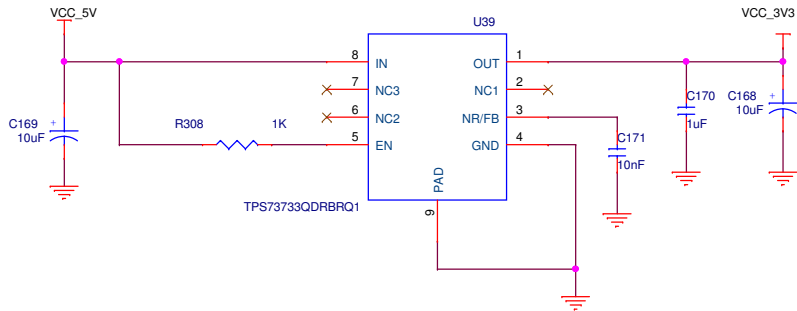
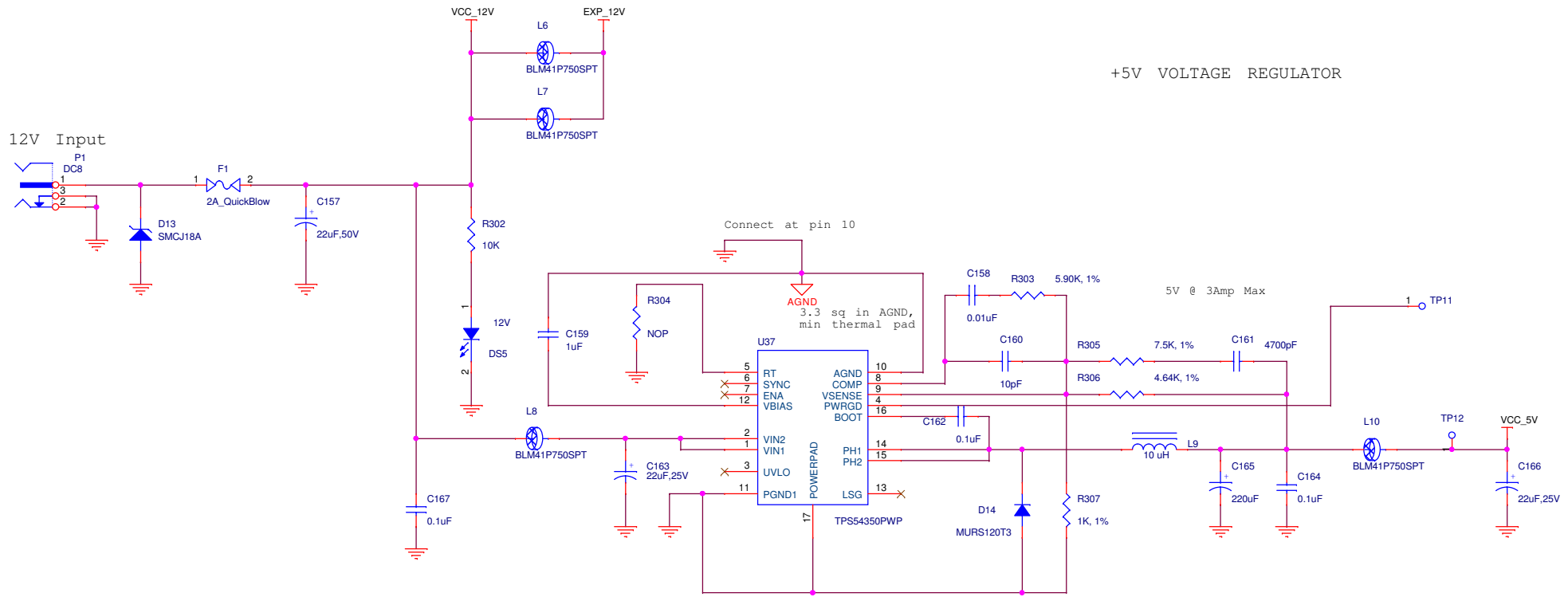

Title		
RM57 HDK		
Size B	Document Number	Rev B
Power Input		
Date:	Tuesday, May 20, 2014	Sheet 27 of 29

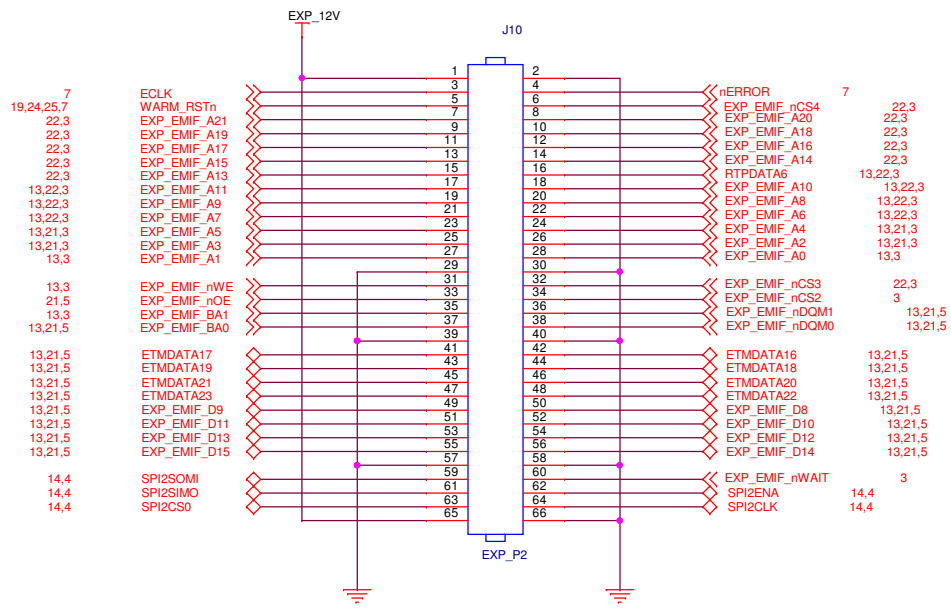
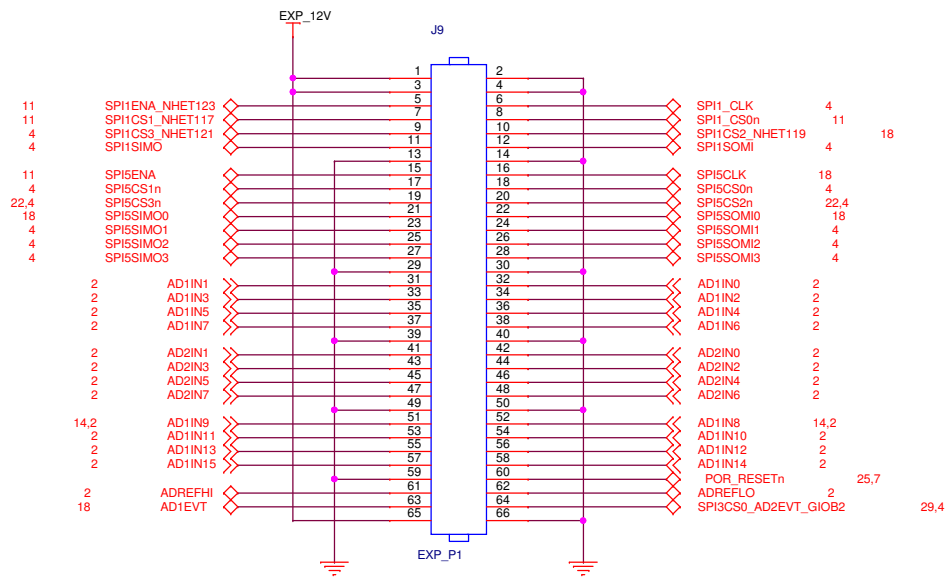

Title		
RM57 HDK		
Size	Document Number	Rev
B	Expansion Connector 1	B
Date:	Tuesday, May 20, 2014	Sheet 28 of 29

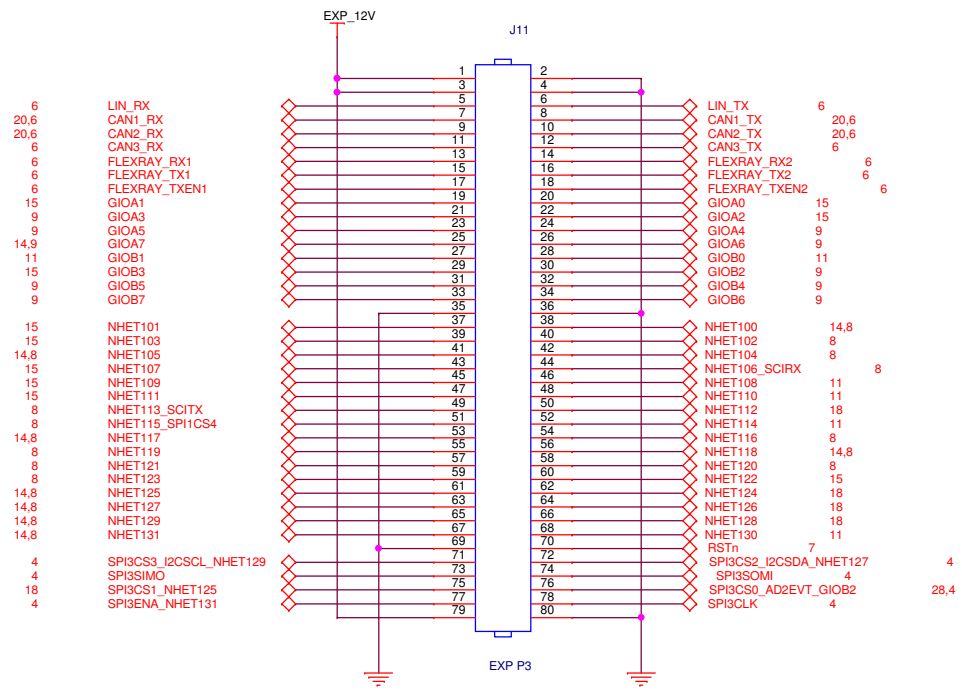

Title		
RM57 HDK		
Size	Document Number	Rev
B	Expansion Connector 2	B
Date:	Tuesday, May 20, 2014	Sheet 29 of 29
		1