

TAS5631DKD2EVM

Audio Products

ABSTRACT

This user's guide describes the operation of the evaluation module for the TAS5631 Digital Amplifier Power Output Stage using TAS5518 Digital Audio PWM Processor from Texas Instruments. The user's guide also provides measurement data and design information like schematic, BOM and PCB layout.

Contents

1	Overview	3
1.1	TAS5631DKD2EVM Features	4
1.2	PCB Key map	5
2	Quick Setup Guide	5
2.1	Electrostatic Discharge Warning	5
2.2	Unpacking the EVM	6
2.3	Power Supply Setup	6
2.4	Speaker Connection	7
2.5	Output configuration BTL and PBTL	8
2.6	GUI Software Installation	8
3	Protection	9
3.1	Short Circuit Protection and Fault Reporting Circuitry	9
3.2	Fault Reporting	10
4	TAS5631DKD2EVM Performance	11
4.1	THD+N vs. Power (BTL – 4 Ω)	13
4.2	THD+N vs. Power (BTL – 8 Ω)	13
4.3	THD+N vs. Power (PBTL – 2 Ω)	14
4.4	THD+N vs. Frequency (BTL – 4 Ω)	14
4.5	THD+N vs. Frequency (BTL – 8 Ω)	15
4.6	THD+N vs. Frequency (PBTL – 2 Ω)	15
4.7	FFT Spectrum with -60 dBFS Tone (BTL)	16
4.8	FFT Spectrum with -60 dBFS Tone (PBTL).....	16
4.9	Idle Noise FFT Spectrum (BTL).....	17
4.10	Idle Noise FFT Spectrum (PBTL)	17
4.11	Channel Separation	18
4.12	Frequency Response (BTL).....	19
4.13	Frequency Response (PBTL)	19
4.14	High Current Protection (BTL)	20
4.15	High Current Protection (PBTL).....	20
4.16	Pop/Click (BTL)	21
4.17	Pop/Click (PBTL)	21
4.18	Output Stage Efficiency	22
5	Related Documentation from Texas Instruments	23
5.1	Additional Documentation	24
Appendix A. Design Documents		25
A.1	TAS5631DKD2EVM Schematic.....	25
A.2	TAS5631DKD2EVM Partslist.....	25
A.3	TAS5631DKD2EVM PCB Specification.....	25
A.4	TAS5631DKD2EVM PCB Layers	25
A.5	Heat Sink Drawing.....	25

Figures

Figure 1.	Integrated PurePath Digital™ Amplifier System	4
Figure 2.	Physical structure for the TAS5631DKD2EVM (Approximate Layout)	5

PurePath Digital, Equibit are trademarks of Texas Instruments

Windows is a trademark of Microsoft Corporation.

TAS5631DKD2EVM User's Guide (1.00).doc

Figure 3.	PBTL Mode Configuration.....	8
Figure 4.	TAS5518 GUI window	9
Figure 5.	THD+N vs. Power (BTL – 4 Ω).....	13
Figure 6.	THD+N vs. Power (BTL – 8 Ω).....	13
Figure 7.	THD+N vs. Power (PBTL – 2 Ω).....	14
Figure 8.	THD+N vs. Frequency (BTL – 4 Ω).....	14
Figure 9.	THD+N vs. Frequency (BTL – 8 Ω).....	15
Figure 10.	THD+N vs. Frequency (PBTL – 2 Ω)	15
Figure 11.	FFT Spectrum with -60 dBFS Tone (BTL)	16
Figure 12.	FFT Spectrum with -60 dBFS Tone (PBTL)	16
Figure 13.	Idle Noise FFT Spectrum (BTL).....	17
Figure 14.	Idle Noise FFT Spectrum (PBTL)	17
Figure 15.	Channel Separation	18
Figure 16.	Frequency Response (BTL)	19
Figure 17.	Frequency Response (PBTL).....	19
Figure 18.	High Current Protection (BTL).....	20
Figure 19.	High Current Protection (PBTL).....	20
Figure 20.	Pop/Click (BTL)	21
Figure 21.	Pop/Click (PBTL).....	21
Figure 22.	Output Stage Efficiency.....	22

Tables

Table 1.	TAS5631DKD2EVM Specification.....	3
Table 2.	Recommended supply voltages	7
Table 3.	TAS5631 Warning/error signal decoding.....	10
Table 4.	General Test Conditions.....	11
Table 5.	TAS5518 Register Settings	11
Table 6.	Electrical Data	11
Table 7.	Audio Performance	12
Table 8.	Thermal specification	12
Table 9.	Physical Specifications	12
Table 10.	Related Documentation from Texas Instruments	23

1 Overview

The TAS5631DKD2EVM PurePath™ HD customer evaluation module demonstrates the integrated circuits TAS5631DKD and TAS5518PAG from Texas Instruments (TI).

The TAS5631DKD is a high-performance, integrated Stereo Feedback Digital Amplifier Power Stage designed to drive 4 Ohm speakers at up to 300 W per channel. The device incorporates TI's Equibit™ technology and is designed to be used with TI's Equibit™ modulators. This system requires only a simple passive demodulation filter to deliver high-quality, high-efficiency audio amplification.

TAS5518PAG is a high performance 32 bit (24 bit input) multi channel PurePath Digital™ Pulse Width Modulator (PWM) based on Equibit™ technology with fully symmetrical AD modulation scheme. The device also has Digital Audio Processing (DAP) that provides 48 bit signal processing, advanced performance and a high level of system integration. The device has interfaces for headphone output and Power Supply Volume Control (PSVC).

This EVM is easy configurable to 2 BTL channels for stereo evaluation or 1 PBTL (parallel BTL) channel for subwoofer evaluation.

This EVM, together with a TI input-USB board 2, is a complete stereo digital audio amplifier system which includes digital input (S/PDIF), analog inputs, interface to PC and DAP features like digital volume control, input and output mixers, automute, tone controls, loudness, EQ filters and dynamic range compression (DRC). There are configuration options for power stage failure protection.

Table 1. TAS5631DKD2EVM Specification

Key Parameters	
Output Stage Supply Voltage:	20V – 50 V
Number of Channels	2 x BTL or 1 x PBTL
Load Impedance BTL:	4-8 Ohm
Load Impedance PBTL:	2-3 Ohm
Output power BTL	330 W / 4 Ohm 10% THD or 180 W / 8 Ohm / 10% THD
Output power PBTL	600 W / 2 Ohm / 10% THD
DNR	>105 dB
PWM Processor	TAS5518PAG
Output Stage	TAS5631DKD

This document covers EVM specifications, audio performance & power efficiency measurements graphs, and design documentation that includes schematics, parts list, layout and mechanical design.

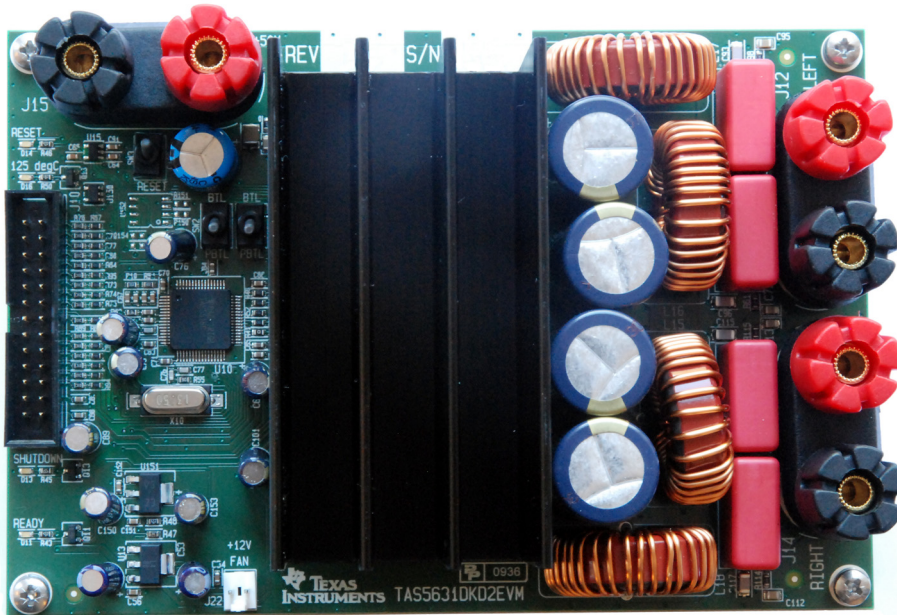

Gerber (layout) files are available at www.ti.com.

The EVM is delivered with cables and Input-USB board 2 to connect to an input source and be controlled from a PC.

1.1 TAS5631DKD2EVM Features

- Stereo PurePath Digital™ evaluation module.
- Self-contained protection system (short circuit & thermal).
- Standard I²S and I²C / Control connector for TI input board
- Double-sided plated-through PCB layout.

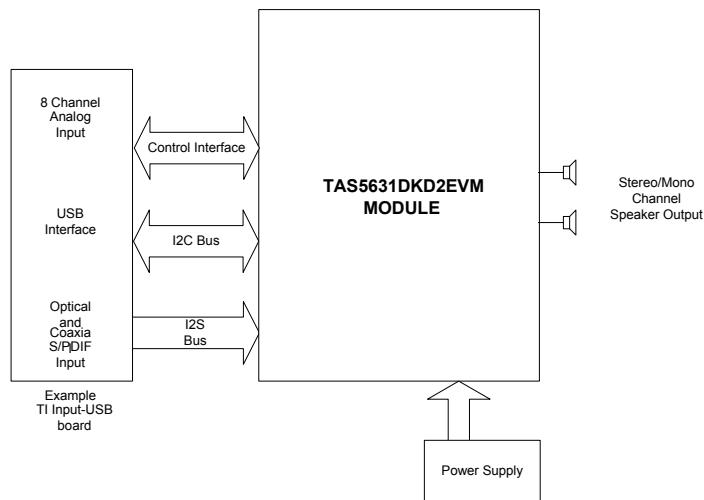

Figure 1. Integrated PurePath Digital™ Amplifier System

1.2 PCB Key map

Physical structure for the TAS5631DKD2EVM is illustrated in the figure below.

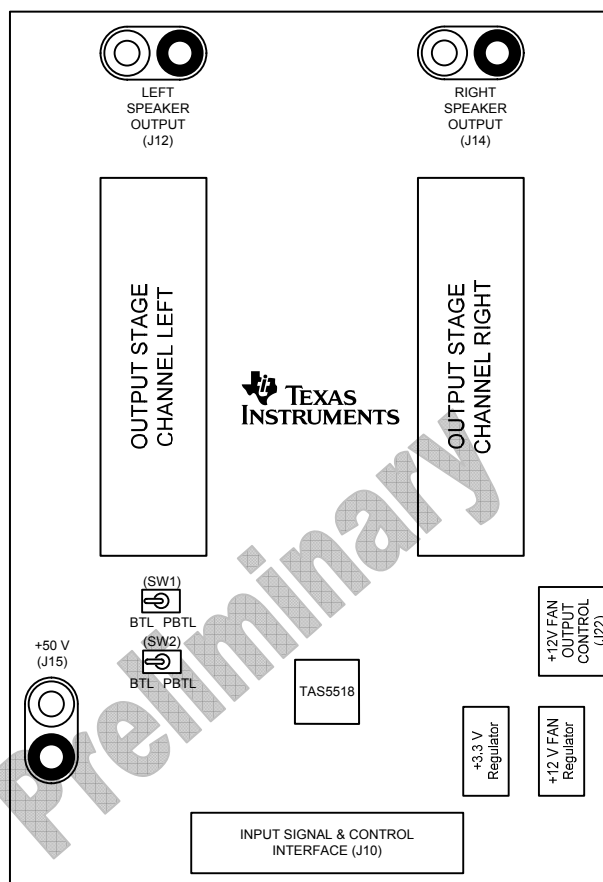

Figure 2. Physical structure for the TAS5631DKD2EVM (Approximate Layout)

2 Quick Setup Guide

This chapter describes the TAS5631DKD2EVM board in regards to power supplies and system interfaces. The chapter provides information regarding handling and unpacking, absolute operating conditions, and a description of the factory default switch and jumper configuration.

This chapter provides a step-by-step guide to configuring the TAS5631DKD2EVM for device evaluation.

2.1 Electrostatic Discharge Warning

Many of the components on the TAS5631DKD2EVM are susceptible to damage by electrostatic discharge (ESD). Customers are advised to observe proper ESD handling precautions when unpacking and handling the EVM, including the use of a grounded wrist strap at an approved ESD workstation.

Caution: Failure to observe ESD handling procedures may result in damage to EVM components.

CAUTION

2.2 Unpacking the EVM

Upon opening the TAS5631DKD2EVM package, please check to make sure that the following items are included:

- 1 pc. TAS5631DKD2EVM board using one TAS5518PAG and one TAS5631DKD.
- 1 pc. TI Input-USB board 2 for interfacing TAS5631DKD2EVM w. SPDIF/analog sources and PC for control.
- 1 pc. Signal & Control Interface IDC cable for connection to an I2S front-end like the attached TI Input-USB board 2.
- 1 pc. Cable for connecting Input-USB board 2 to a USB port on a PC for TAS5518 control by software.
- 1 pc. AC to DC External 15 V Power supply (System supply).
- 4 pcs. AC Input Clips for External 15 V Power Supply (US, Europe, UK and Australia).
- 1 pc. PurePath CD-ROM.

If any of these items are missing, please contact the Texas Instruments Product Information Center nearest you to inquire about a replacement.

Connect Input-micro board to TAS5631DKD2EVM using the delivered IDC cable.

2.3 Power Supply Setup

To power up the EVM, two power supplies are needed. One for system power, logic and gate-drive, and one for output stage supply. H-bridge Power supply is connected to the EVM using banana cables. System Power Supply is supplied from the enclosed External 15 V wall plug adapter.

Table 2. Recommended supply voltages

Description	Voltage limitations	Current requirement	Cable
Output stage power supply	20 – 50 V	16 A	J15 (marked +50V)

Caution: Applying voltages above the limitations given in table above may cause permanent damage to your hardware

CAUTION

Note:

The length of power supply cable must be minimized. Increasing length of PSU cable is equal to increasing the distortion for the amplifier at high output levels and low frequencies.

2.4 Speaker Connection

Caution: Both positive and negative speaker outputs are floating and may not be connected to ground (e.g. through an oscilloscope)

CAUTION

2.5 Output configuration BTL and PBTL

When changing mode e.g. from BTL to PBTL make sure that RESET is activated before changing the state of mode switches SW1 and SW2. Switch SW1 and SW2 has to be synchronized in state BTL or PBTL.

In PBTL mode the load has to be connected according to the figure below:

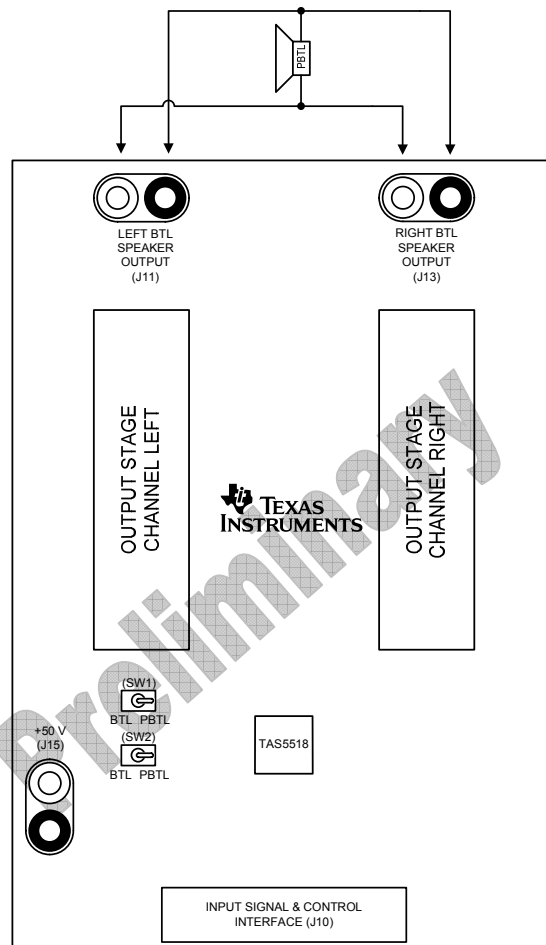

Figure 3. PBTL Mode Configuration

2.6 GUI Software Installation

The TAS5518 GUI provides easy control of all registers in TAS5518. To install the GUI run setup file from the PurePath CD-rom.

After installation turn on power supplies and connect USB cable to Input-USB board 2.

Start GUI program from windows menu. Start up of GUI will take a few seconds.

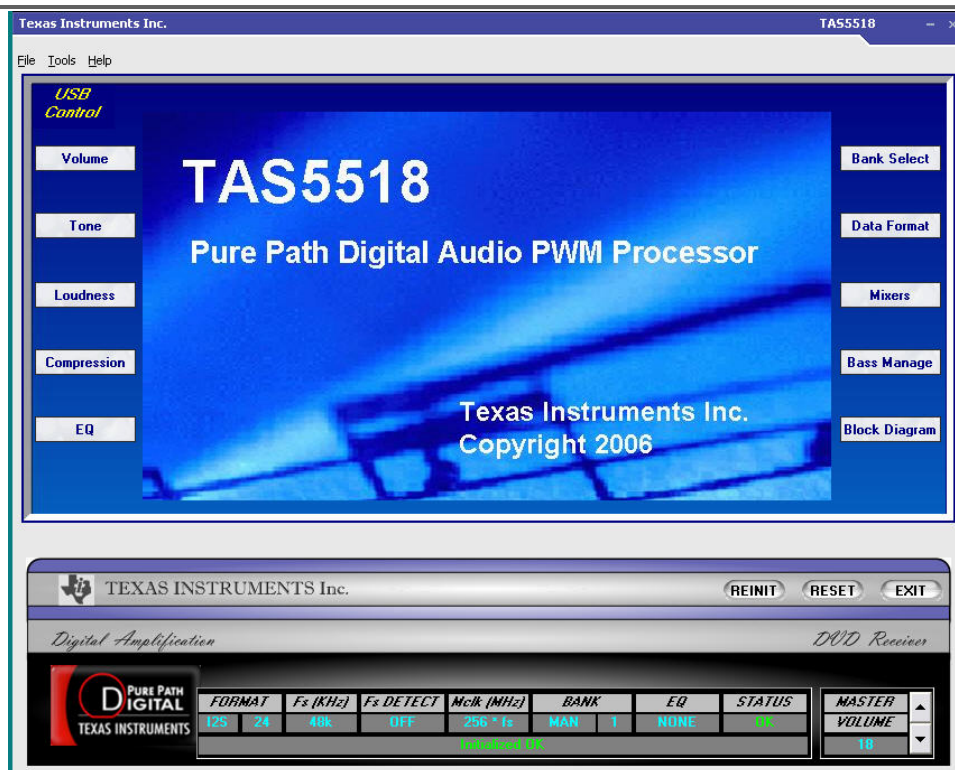

Figure 4. TAS5518 GUI window

From the files menu load the configuration file:

TAS5631DKD2EVM Configuration (1.00).cfg

The file is located on the PurePath CD-rom. This file contains all settings for a default setup of the EVM.

For easy access of the file it is recommended to copy the files into directory where the GUI is installed. Default is C:\Program Files\Texas Instruments Inc\TAS5518\

For more advanced use of the GUI please refer to GUI User's Guide and data manual for TAS5518.

3 Protection

This chapter describes the short circuit protection and fault reporting circuitry of the TAS5631 device.

3.1 Short Circuit Protection and Fault Reporting Circuitry

The TAS5631 is a self-protecting device that provides fault reporting (including high-temperature protection and short circuit protection). TAS5631 is configured in back-end auto-recovery mode and therefore resets automatically after all errors (M1, M2 and M3 is set low), see datasheet for further explanation. This mean that the device will re-start it self after an error occasion and report shortly through the /SD error signal.

3.2 Fault Reporting

The /OTW and /SD outputs from TAS5631 indicate fault conditions. Please refer to the TAS5631 data manual for a description of these pins.

Table 3. TAS5631 Warning/error signal decoding

/SD	/OTW1	/OTW2	Device Condition
0	0	0	High temperature error and/or high current error
0	0	1	Under voltage lockout or high current error. 100°C temperature warning.
0	1	1	Under voltage lockout or high current error
1	0	0	125°C temperature warning
1	0	1	100°C temperature warning
1	1	1	Normal operation, no errors/warnings

The shutdown signals will together with the temperature warning signal give chip state information as described in the table above. Device fault reporting outputs are open-drain outputs.

Preliminary

4 TAS5631DKD2EVM Performance

Table 4. General Test Conditions

General Test Conditions		Notes
Output Stage Supply Voltage:	50.0 V	Laboratory Power Supply (EA-PS 7065-10A)
Load Impedance BTL:	4-8 Ohm	
Load Impedance PBTL:	2 Ohm	
Input Signal	1kHz Sine	
Sampling Frequency	48 kHz	
Gain setting in TAS5518	0 dB	
Measurement Filter	AES17 and AUX0025	
TI Input Board	Input-USB 2	Rev 1
EVM configuration file	Ver 1.00	TAS5631DKD2EVM Configuration (1.00).cfg

Note: These test conditions are used for all tests, unless otherwise specified.

Table 5. TAS5518 Register Settings

Register	Register	Value	Notes
System Control Register 2	0x04	0x60	PWM Automute Detection Disabled
Master Volume Register	0xD9	00 00 00 48	Master Volume set to 0 dB

Note: These register settings are used for all test, unless otherwise specified.

Table 6. Electrical Data

Electrical Data		Notes/Conditions
Output Power, BTL, 4 Ohm:	180 W	1 kHz, unclipped (0dBFS), $T_A = 25^\circ\text{C}$
Output Power, BTL, 4 Ohm:	330 W	1 kHz, 10% THD+N, $T_A = 25^\circ\text{C}$
Output Power, BTL, 8 Ohm:	100 W	1 kHz, unclipped (0dBFS), $T_A = 25^\circ\text{C}$
Output Power, BTL, 8 Ohm:	180 W	1 kHz, 10% THD+N, $T_A = 25^\circ\text{C}$
Output Power, PBTL, 2 Ohm:	330 W	1 kHz, unclipped (0 dBFS), $T_A = 25^\circ\text{C}$
Output Power, PBTL, 2 Ohm:	600 W	1 kHz, 10% THD+N, $T_A = 25^\circ\text{C}$, $T_C < 50^\circ\text{C}$
Maximum Peak Current, BTL:	>16 A	1 kHz burst, 1 Ohm, $R_{OC} = 24\text{ kOhm}$
Maximum Peak Current, PBTL:	>28 A	1 kHz burst, 1 Ohm, $R_{OC} = 24\text{ kOhm}$
Output Stage Efficiency:	>94 %	2 x channels, 8 Ohm
Damping Factor BTL:	>16	1 kHz, relative to 4 Ohm load
Damping Factor PBTL:	>18	1 kHz, relative to 2 Ohm load
H-Bridge Supply Current:	<65 mA	1 kHz, -60dBFS signal
Idle Power Consumption:	3.3 W	H-Bridge supply, -60dBFS input signal

Table 7. Audio Performance

Audio Performance	Notes/Conditions		
THD+N, BTL, 4 Ohm:	1 W	<0.02 %	1 kHz
THD+N, BTL, 4 Ohm:	10 W	<0.02 %	1 kHz
THD+N, BTL, 4 Ohm:	50 W	<0.02 %	1 kHz
THD+N, BTL, 4 Ohm:	200 W	<0.5 %	1 kHz
THD+N, BTL, 8 Ohm:	1 W	<0.02 %	1 kHz
THD+N, BTL, 8 Ohm:	10 W	<0.02 %	1 kHz
THD+N, BTL, 8 Ohm:	50 W	<0.02 %	1 kHz
THD+N, BTL, 8 Ohm:	100 W	<0.5 %	1 kHz
THD+N, PBTL, 2 Ohm:	1 W	<0.02 %	1 kHz
THD+N, PBTL, 2 Ohm:	10 W	<0.02 %	1 kHz
THD+N, PBTL, 2 Ohm:	100 W	<0.03 %	1 kHz
THD+N, PBTL, 2 Ohm:	200 W	<0.05 %	1 kHz
THD+N, PBTL, 2 Ohm:	400 W	<0.5 %	1 kHz
Dynamic Range:	>105 dB	Ref: rated power, A-weighted, AES17 filter, 4 ch avg	
Noise Voltage:	<190 μV_{rms}	A-weighted, AES17 filter	
Click/Pop, DC step BTL:	18 mV	Mute/Unmute, No signal, 6 Ohm	
Click/Pop, DC step PBTL:	18 mV	Mute/Unmute, No signal, 4 Ohm	
Channel Separation:	>80 dB	1 kHz,	
Frequency Response:	+0.5 / -1 dB	100 W / 8 Ohm	

Table 8. Thermal specification

Thermal specification**	T_{HEATSINK}*	Notes/Conditions
Idle, All Channels Switching	28 °C	1 kHz, 15 min, -60dBFS signal, T _A = 25°C
2x40 W, 4 Ohm (1/8 power)	42 °C	1 kHz, 1 hour, T _A = 25°C
2x200 W, 4 Ohm	62 °C	1 kHz, 5 min, T _A = 25°C

*Measured on surface of heat sink.

Table 9. Physical Specifications

Physical Specifications	Notes/Conditions	
PCB Dimensions:	94 x 140 x 55	Width x Length x Height (mm)
Total Weight:	380 gr.	Components + PCB + Heat-sink + Mechanics

Note: All electrical and audio specifications are typical values.

4.1 THD+N vs. Power (BTL – 4 Ω)

Gain: +2.5dB set in TAS5518

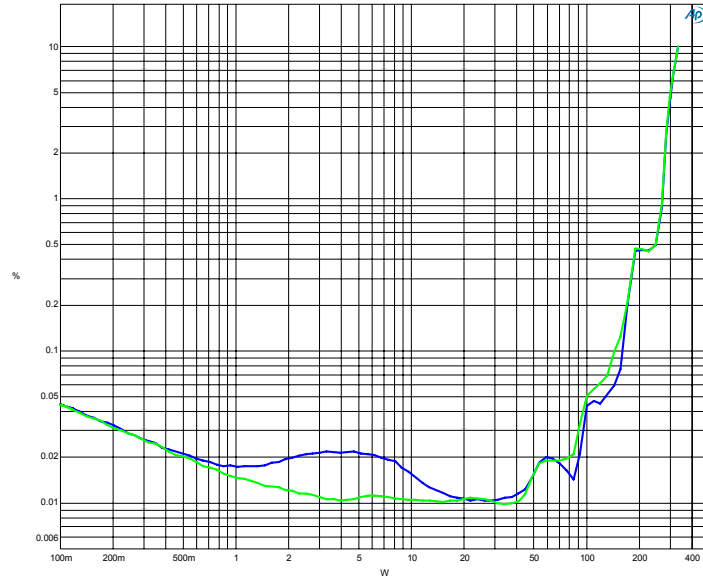

Figure 5. THD+N vs. Power (BTL – 4 Ω)

4.2 THD+N vs. Power (BTL – 8 Ω)

Gain: +2.5dB set in TAS5518

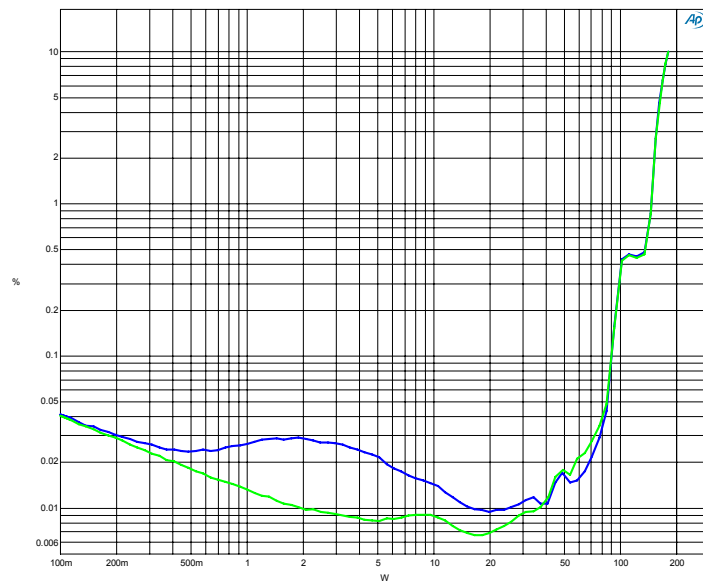

Figure 6. THD+N vs. Power (BTL – 8 Ω)

4.3 THD+N vs. Power (PBTL – 2 Ω)

Gain: +2.5dB set in TAS5518

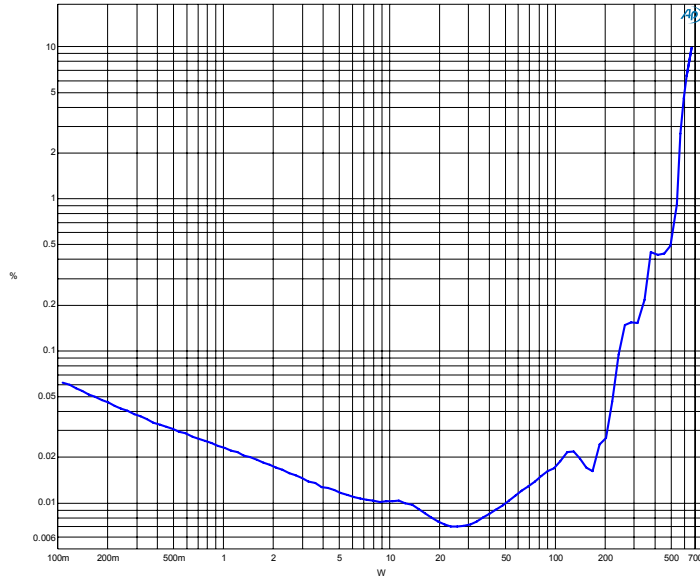
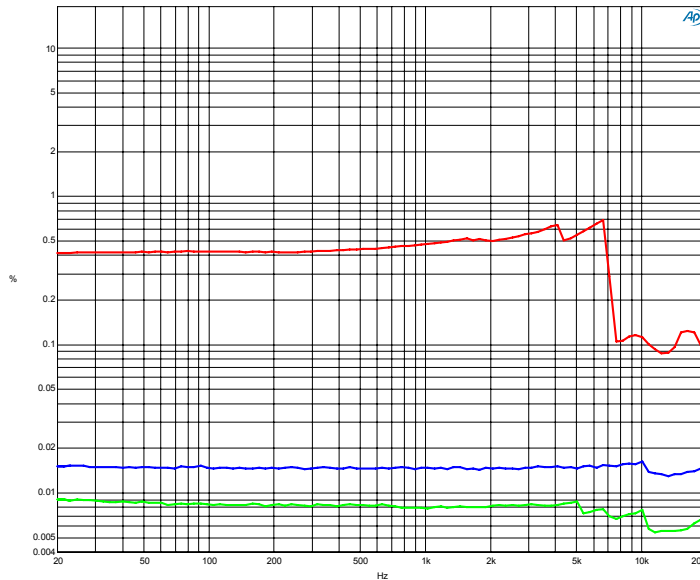

Figure 7. THD+N vs. Power (PBTL – 2 Ω)

4.4 THD+N vs. Frequency (BTL – 4 Ω)



Comments: Blue: 1 watt Green: 10 watts Red: 200 watts (-2 dBFS)

Figure 8. THD+N vs. Frequency (BTL – 4 Ω)

4.5 THD+N vs. Frequency (BTL – 8 Ω)

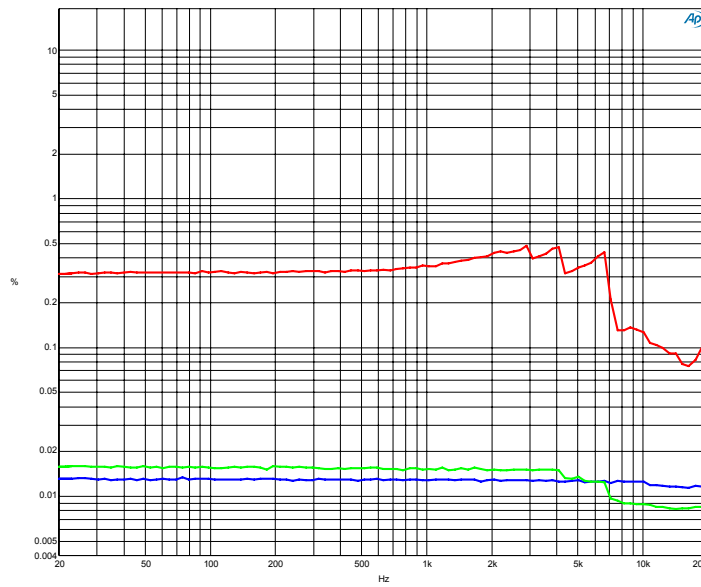

Comments: Blue: 1 watt Green: 10 watts Red: 100 watts (-2 dBFS)

Figure 9. THD+N vs. Frequency (BTL – 8 Ω)

4.6 THD+N vs. Frequency (PBTL – 2 Ω)

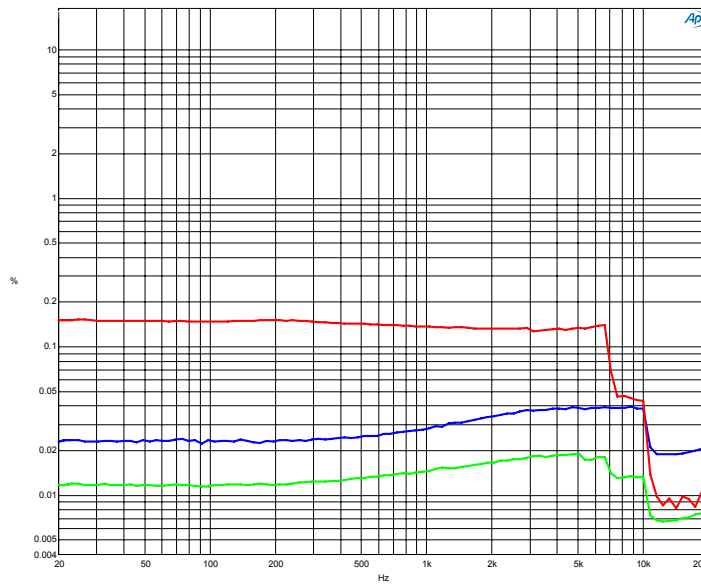

Comments: Blue: 1 watt Green: 10 watts Red: 300 W (-3 dBFS)

Figure 10. THD+N vs. Frequency (PBTL – 2 Ω)

4.7 FFT Spectrum with -60 dBFS Tone (BTL)

Reference voltage is 32.5Vrms. FFT size 16k.

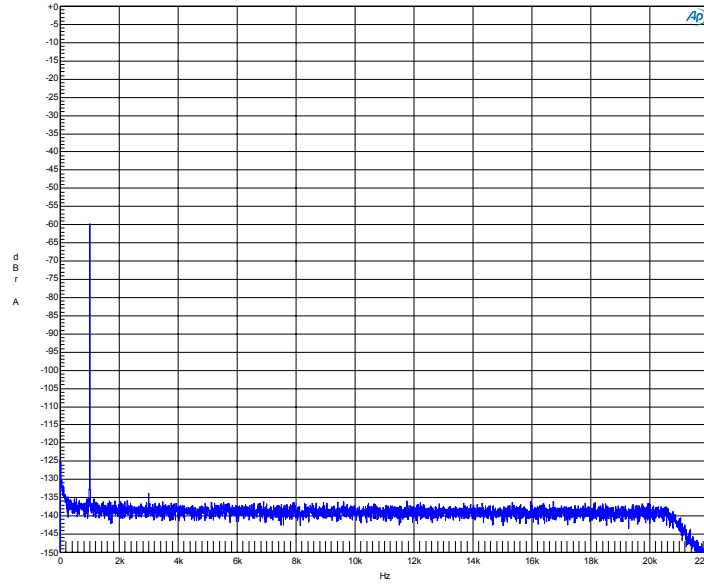

Figure 11. FFT Spectrum with -60 dBFS Tone (BTL)

4.8 FFT Spectrum with -60 dBFS Tone (PBTl)

Reference voltage is 24.8Vrms. FFT size 16k.

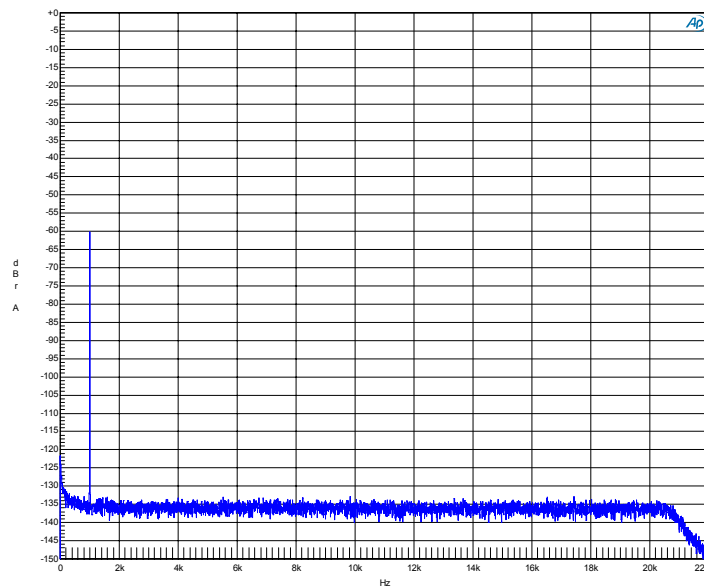

Figure 12. FFT Spectrum with -60 dBFS Tone (PBTl)

4.9 Idle Noise FFT Spectrum (BTL)

Automute disabled – Register x04h set to x60h. Reference voltage is 32.5 V. FFT size 16k.

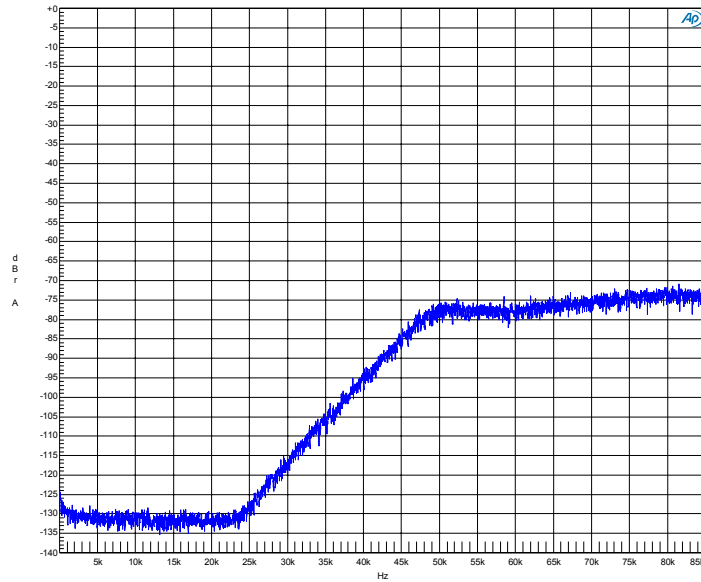

Figure 13. Idle Noise FFT Spectrum (BTL)

4.10 Idle Noise FFT Spectrum (PBTL)

Automute disabled – Register x04h set to x60h. Reference voltage is 24.8 V. FFT size 16k.

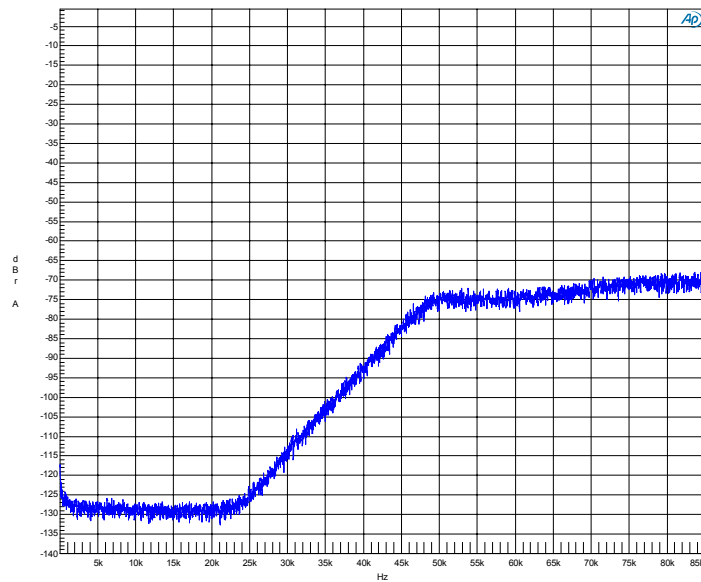
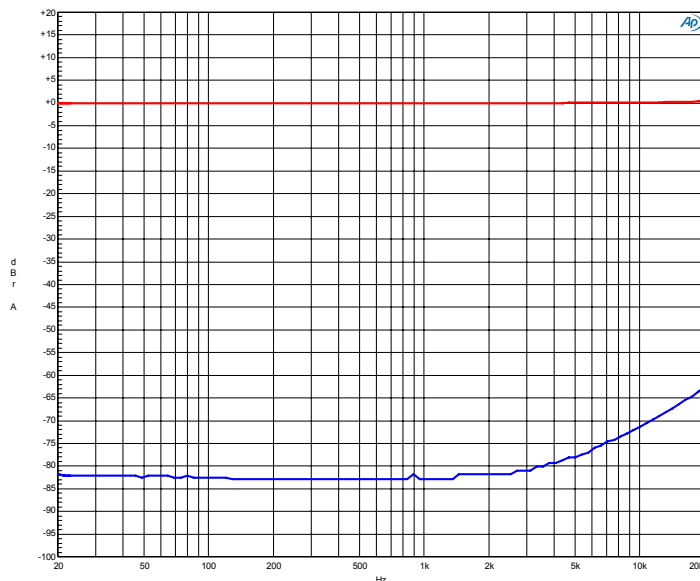

Figure 14. Idle Noise FFT Spectrum (PBTL)

4.11 Channel Separation

Channel 2 input signal is 100 W, channel 1 muted.



Comments: Blue: Channel 1 Red: Channel 2

Figure 15. Channel Separation

Preliminary

4.12 Frequency Response (BTL)

Measurement bandwidth filter 80kHz.

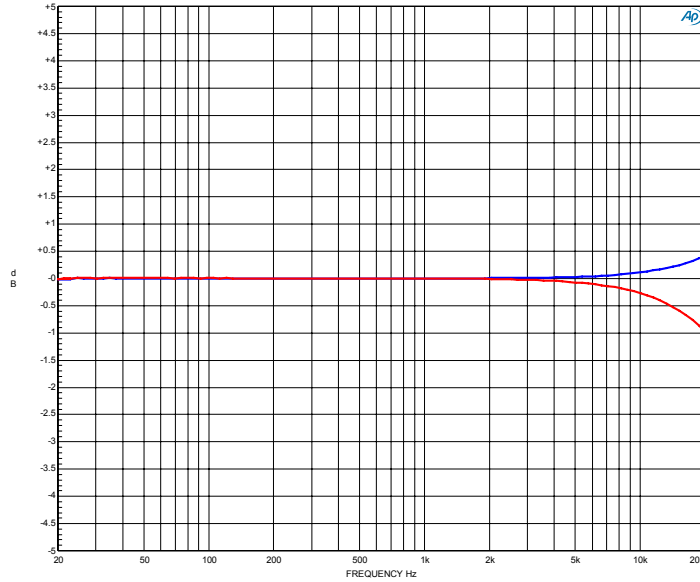

Comments: Blue: 8 Ohm Red: 4 Ohm

Figure 16. Frequency Response (BTL)

4.13 Frequency Response (PBTL)

Measurement bandwidth filter 80kHz.

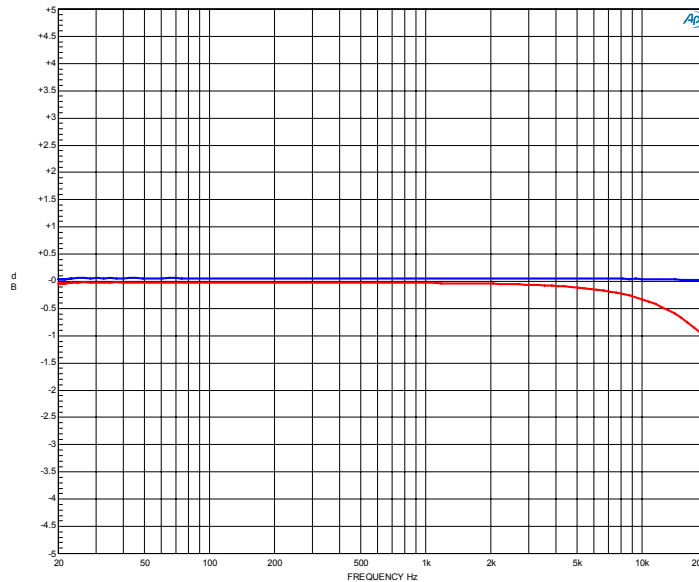

Comments: Blue: 3 Ohm Red: 2 Ohm

Figure 17. Frequency Response (PBTL)

4.14 High Current Protection (BTL)

Input 1kHz bursted signal, Load 1 Ohm.

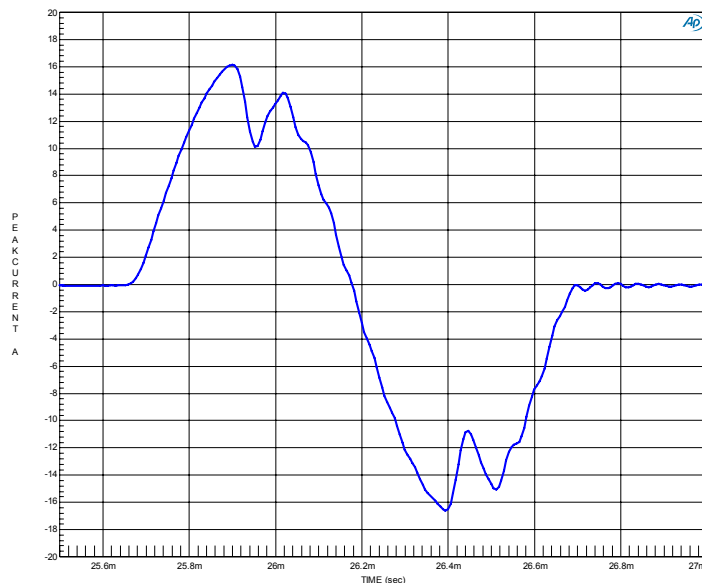

Figure 18. High Current Protection (BTL)

4.15 High Current Protection (PBTL)

Input 1kHz bursted signal, Load 1 Ohm.

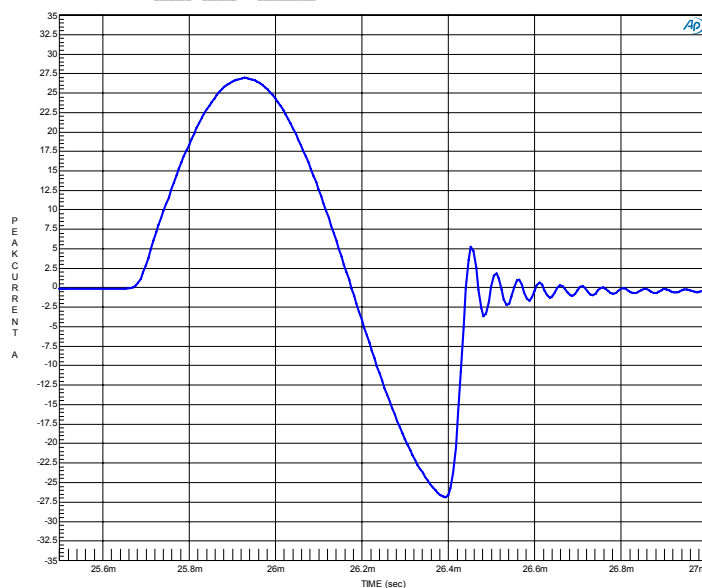

Figure 19. High Current Protection (PBTL)

4.16 Pop/Click (BTL)

No input signal applied. The measurement results are presented in time domain.

Test with automute disabled – Register x04h set to x60h. No input signal applied. Load 4 Ohm.

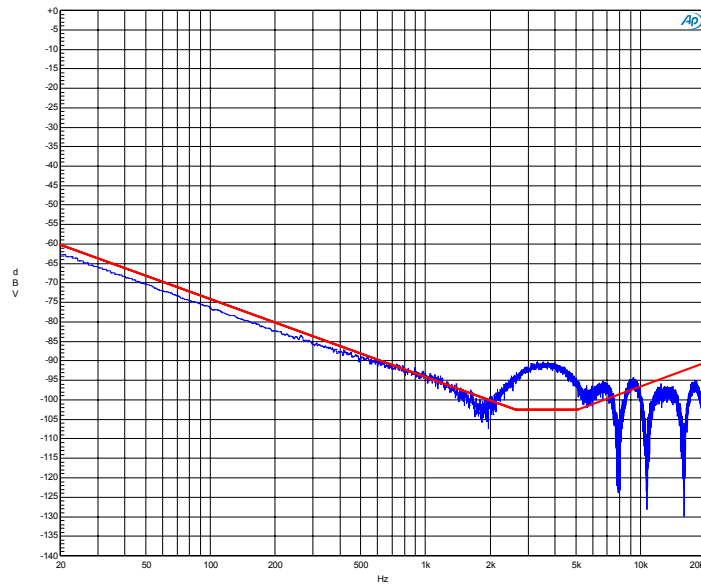

Figure 20. Pop/Click (BTL)

4.17 Pop/Click (PBTL)

No input signal applied. The measurement results are presented in time domain.

Test with automute disabled – Register x04h set to x60h. No input signal applied. Load 2 Ohm

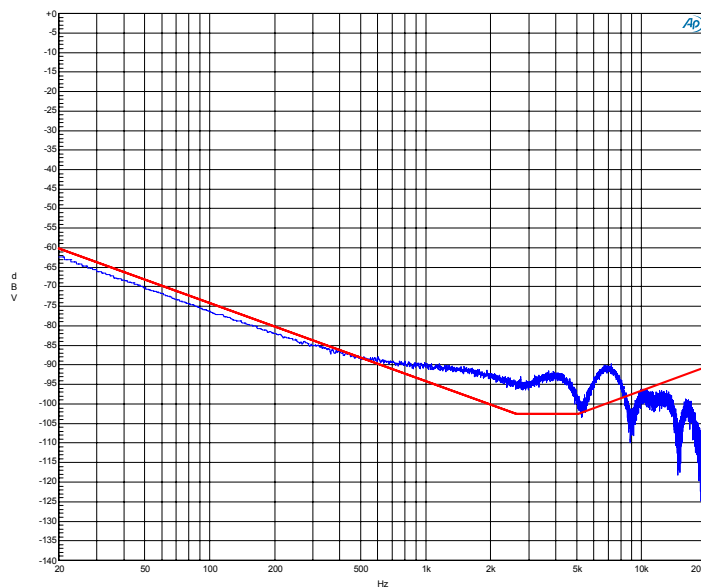

Figure 21. Pop/Click (PBTL)

4.18 Output Stage Efficiency

Efficiency is tested with 2 channels loaded 4 Ohm.

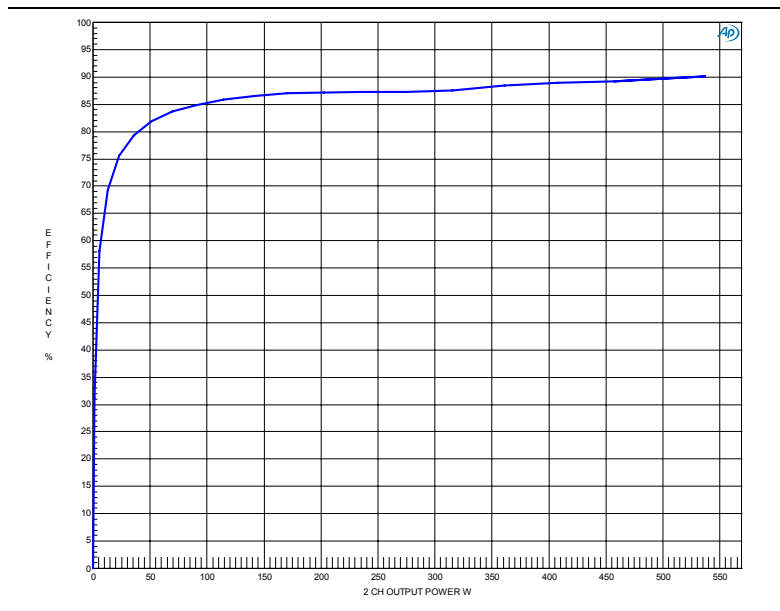

Figure 22. Output Stage Efficiency

Preliminary

5 Related Documentation from Texas Instruments

The following table contains a list of data manuals that have detailed descriptions of the integrated circuits used in the design of the TAS5631DKD2EVM. The data manuals can be obtained at the URL <http://www.ti.com>.

Table 10. Related Documentation from Texas Instruments

Part Number	Literature Number
TAS5518	SLES115
TAS5631	SLES221
TLV271	SLOS351
TPS3825-33	SLVS165
TLV1117-33C	SLVS561

Preliminary

5.1 Additional Documentation

1. *PC Configuration Tool for TAS5518* (TAS5518 GUI ver. 4.0 or later)
2. *System Design Considerations for True Digital Audio Power Amplifiers* (SLAA117)
3. *Digital Audio Measurements* (SLAA114)
4. *PSRR for PurePath Digital Audio Amplifiers* (SLEA049)
5. *Power Rating in Audio Amplifier* (SLEA047)
6. *PurePath Digital AM Interference Avoidance* (SLEA040)
7. *Click & Pop Measurements Technique* (SLEA044)
8. *Power Supply Recommendations for DVD-Receivers* (SLEA027)
9. *Implementation of Power Supply Volume Control* (SLEA038)

Preliminary

Appendix A. Design Documents

A.1	TAS5631DKD2EVM Schematic	Version 2.00	5 pages
A.2	TAS5631DKD2EVM Partslist	Version 2.00	2 pages
A.3	TAS5631DKD2EVM PCB Specification	Version 2.00	1 page
A.4	TAS5631DKD2EVM PCB Layers	Version 2.00	8 pages
A.5	Heat Sink Drawing	Version 2.00	1 Page

Preliminary



Design Name: **TAS5631DKD2EVM**
 Type: Mass Market EVM
 File Name: A853-SCH-001.DSN
 Version: 2.00
 Date: 17 Aug. 2009
 Design Engineer: Jonas L. Holm

Audio Configuration: PurePath Premire Pro Digital Amplifier Design
 1 x TAS5631DKD, 1 x TAS5518

Interfaces: J10: 26 pin IDC Header
 for I2S Audio, Control, I2C, +5V and +12V
 J12, J14: Banana binding posts for speaker connection.
 J15: Banana binding post for H-Bridge Supply
 J22: 2 pins 2.54 mm Header for Supply & control of optional external Fan

Setup: 4-8 Ohm (BTL) Speaker Loads
 +50 V H-Bridge Supply Voltage

Performance: 2 x 300 W / 4 Ohm (BTL) 10% THD+N
 > 104 dB Dynamic Range

Page
 1/5: Front Page and Schematic Disclaimer
 2/5: Frontend overview
 3/5: TAS5631 Amplifier
 4/5: Power Supply
 5/5: Mechanics

NOTE1

SCHEMATIC DISCLAIMER

The preliminary schematic information and materials ("Materials") provided here are provided by Texas Instruments Incorporated ("TI") as a service to its customers and/or suppliers, and may be used for informational purposes only, and only subject to the following terms. By downloading or viewing these Materials, you are signifying your assent to these terms.

- 1.) These preliminary evaluation schematics are intended for use for PRELIMINARY ENGINEERING DEVELOPMENT AND EVALUATION PURPOSES ONLY and are not considered by Texas Instruments to be fit as a basis for establishing production products or systems. This information may be incomplete in several respects, including but not limited to information relating to required design, marketing, and/or manufacturing-related protective considerations and product safety measures typically found in the end-product incorporating the goods.
- 2.) Accordingly, neither TI nor its suppliers warrant the accuracy or completeness of the information, text, graphics, links or other items contained within the Materials. TI may make changes to the Materials, or to the products described therein, at any time without notice. TI makes no commitment to update the Materials.
- 3.) TI assumes no liability for applications assistance, customer product design, software performance, or services that may be described or referenced in the Materials. The user assumes all responsibility and liability for proper and safe design and handling of goods. Accordingly, the user indemnifies TI from all claims arising from its use of the Materials.
- 4.) TI currently deals with various customers for products, and therefore our arrangement with the user will not be exclusive. TI makes no representations regarding the commercial availability of non-TI components that may be referenced in the Materials.
- 5.) No license is granted under any patent right or other intellectual property right of TI covering or relating to any combination, machine, or process in which such TI products or services might be or are used. Except as expressly provided herein, TI and its suppliers do not grant any express or implied right to you under any patents, copyrights, trademarks, or trade secret information.
- 6.) Performance tests and ratings, to the extent referenced in the Materials, are measured using specific computer systems and/or components and reflect the approximate performance of TI products as measured by those tests. Any difference in system hardware or software design or configuration may affect actual performance. Buyers should consult other sources of information to evaluate the performance of systems or components they are considering purchasing.
- 7.) Resale of TI's products or services with statements different from or beyond the parameters stated by TI for that product or service in official TI data books or data sheets voids all express and any implied warranties for the associated TI product or service, and is an unfair and deceptive business practice, and TI is not responsible for any such use.
- 8.) The Materials are copyrighted and any unauthorized use may violate copyright, trademark, and other laws. You may only download one copy for your internal use only, unless you are specifically licensed to do otherwise by TI in writing. This is a license, not a transfer of title, and is subject to the following restrictions: You may not: (a) modify the Materials (including any associated warranties, conditions, limitations or notices) or use them for any commercial purpose, or any public display, performance, sale or rental; (b) decompile, reverse engineer, or disassemble software Materials except and only to the extent permitted by applicable law; (c) remove any copyright or other proprietary notices from the Materials; (d) transfer the Materials to another person. You agree to prevent any unauthorized copying of the Materials. TI may terminate this license at any time if you are in breach of the terms of this Agreement. Upon termination, you will immediately destroy the Materials.
- 9.) THE MATERIALS ARE PROVIDED "AS IS" WITHOUT ANY EXPRESS OR IMPLIED WARRANTY OF ANY KIND INCLUDING WARRANTIES OF MERCHANTABILITY, NONINFRINGEMENT OF INTELLECTUAL PROPERTY, OR FITNESS FOR ANY PARTICULAR PURPOSE. IN NO EVENT SHALL TI OR ITS SUPPLIERS BE LIABLE FOR ANY DAMAGES WHATSOEVER (INCLUDING, WITHOUT LIMITATION, DAMAGES FOR LOSS OF PROFITS, BUSINESS INTERRUPTION, LOSS OF INFORMATION) ARISING OUT OF THE USE OF OR INABILITY TO USE THE MATERIALS, EVEN IF TI HAS BEEN ADVISED OF THE POSSIBILITY OF SUCH DAMAGES.

Not Used

TAS5631 Parts list 2.00



AUDIO/IMAGING GROUP
 Home Audio Amplifiers
 ALL RIGHTS RESERVED
 TEXAS INSTRUMENTS INCORPORATED

Project: TAS5631DKD2EVM	Rev: 2.00
Page Title: Disclaimer	Size: A3
File Name: A853-SCH-001.DSN	Engineer: JLH & JSV
Date: Wednesday, September 30, 2009	Page: 1 of 5

Input and Output Interface: Control, I2C, +5V, +12V and for I2S Audio

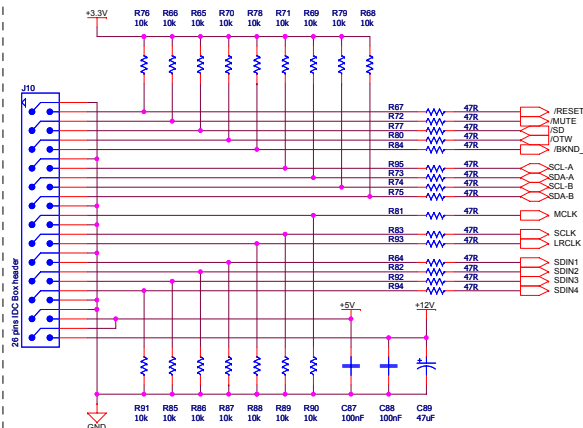

ON/OFF CONTROL

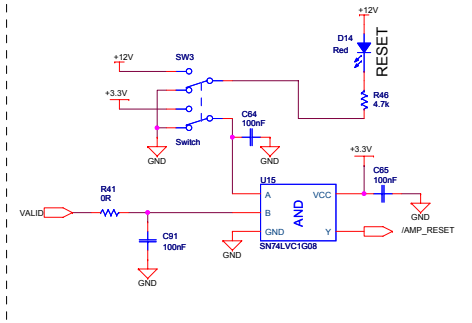

TAS5631 STATUS MONITOR

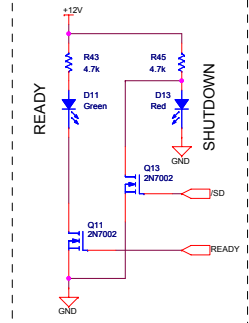

2 SPEED FAN CONTROL & TEMPERATURE INDICATOR

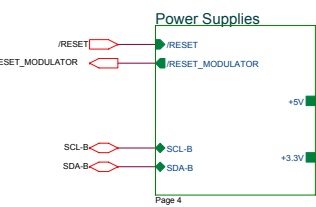
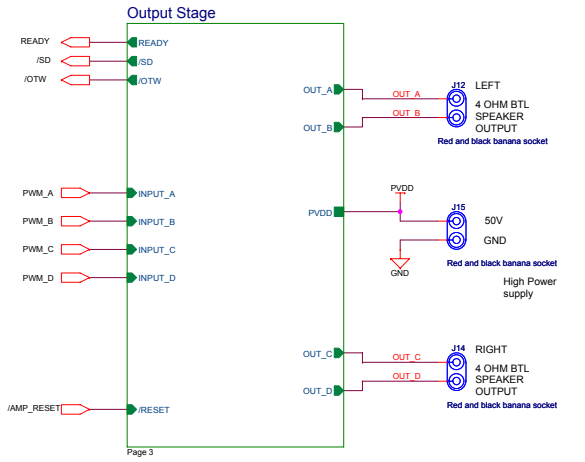
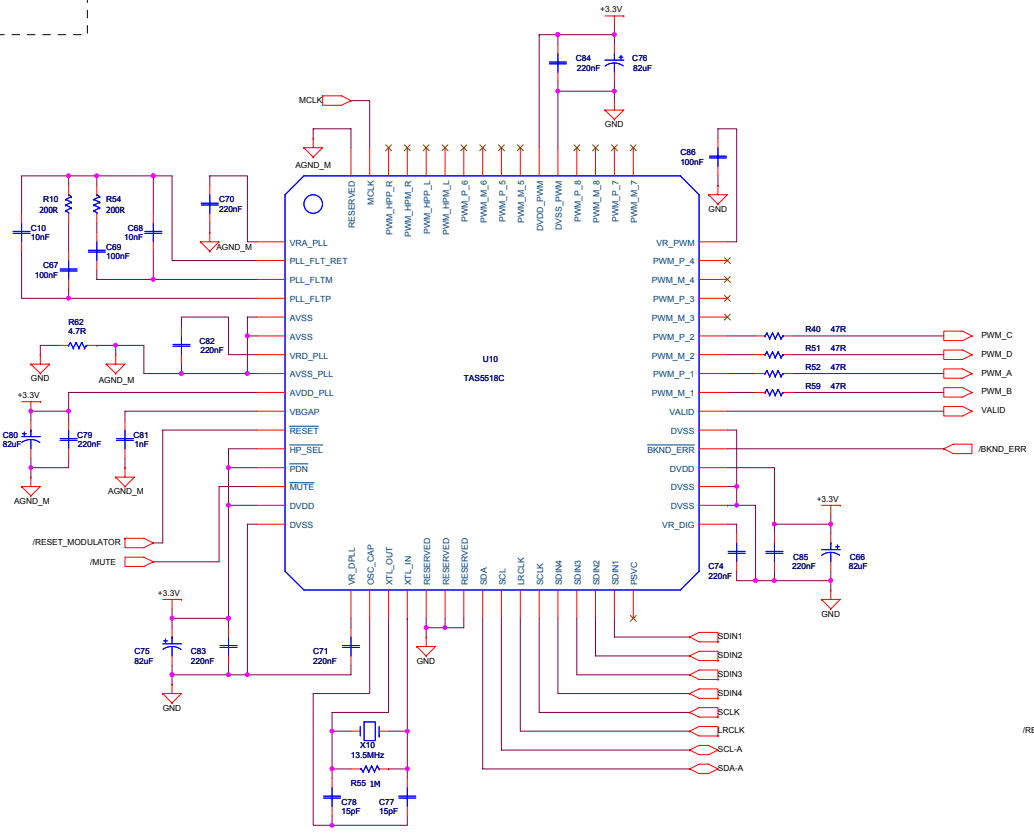
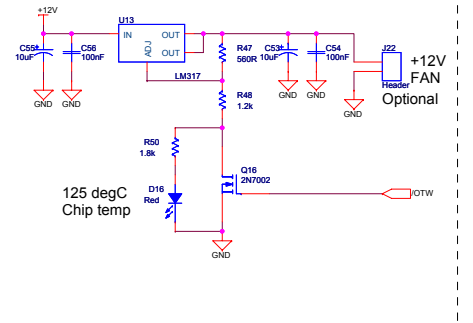

TAS5631 Parts list 2.00

TEXAS INSTRUMENTS
 AUDIO/IMAGING GROUP
 Home Audio Amplifiers
 ALL RIGHTS RESERVED
 TEXAS INSTRUMENTS INCORPORATED

Project: TAS5631DK02EVM	Rev: 2.00
Page Title: Input Stage	Size: A2
File Name: ABS-SCM-Q01.DSN	Engineer: JLM & JSV
Date: Monday, August 24, 2009	Page 2 of 5

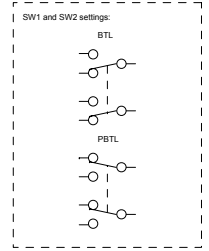
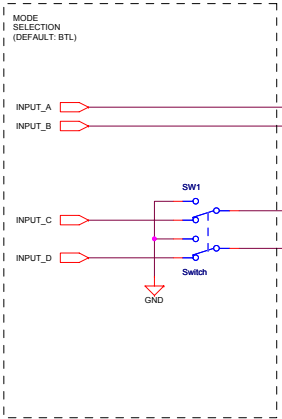
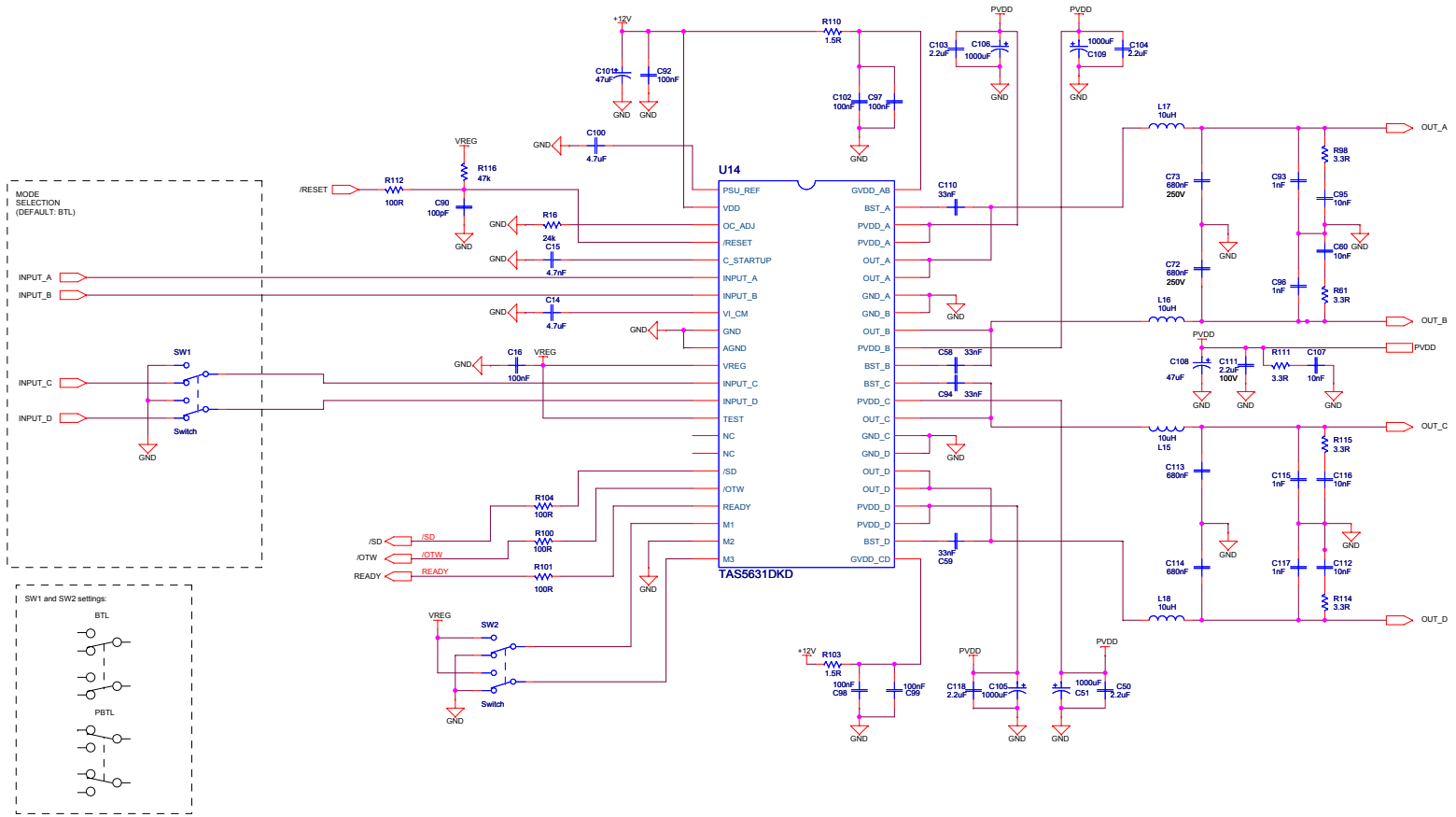

POWER SUPPLIES

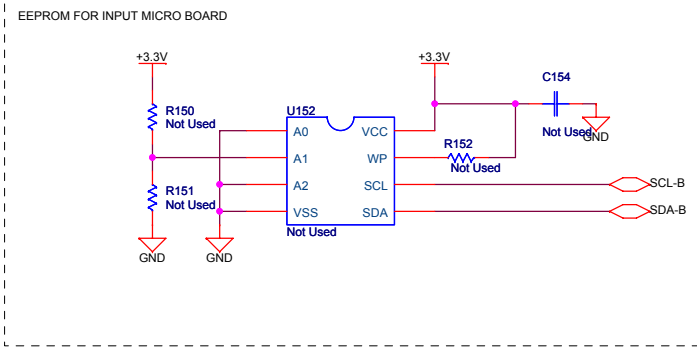
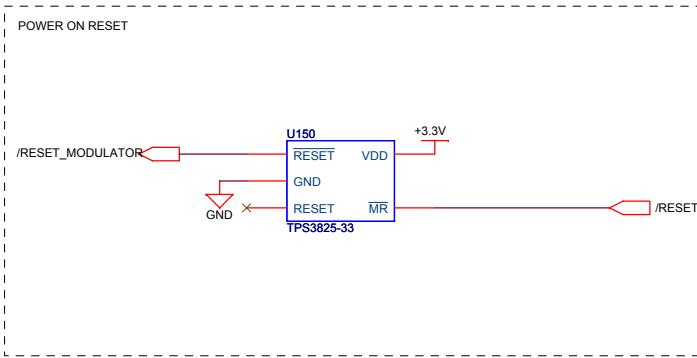
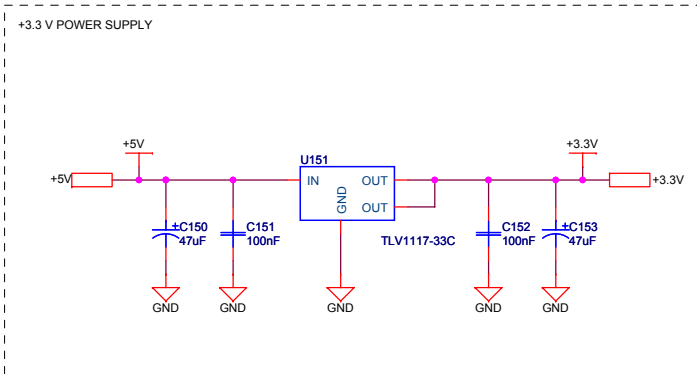

TAS5631 Parts list 2.00



AUDIO/IMAGING GROUP
Home Audio Amplifiers
ALL RIGHTS RESERVED
TEXAS INSTRUMENTS INCORPORATED

Project: TAS5631DKD2EVM	Rev: 2.00
Page Title: Power Supplies	Size: A3
File Name: A853-SCH-001.DSN	Engineer: JLH & JSV
Date: Monday, August 24, 2009	Page: 4 of 5

MECHANICS

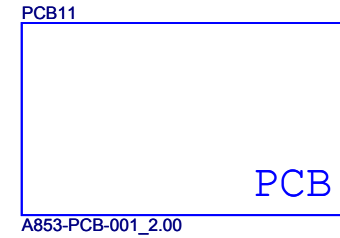
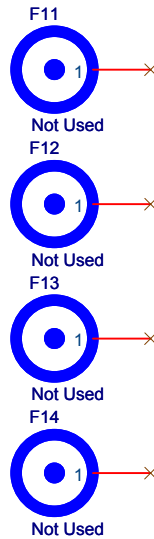
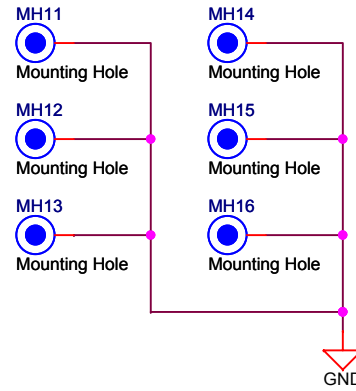
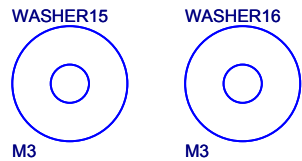
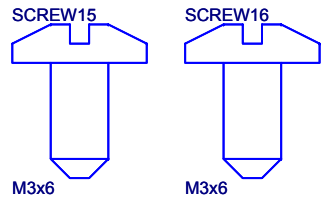
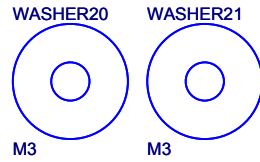
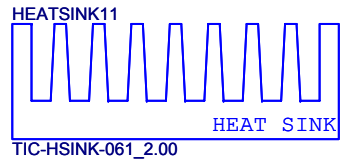
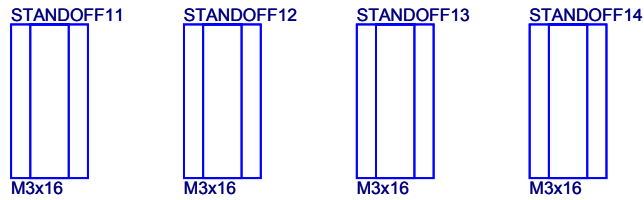
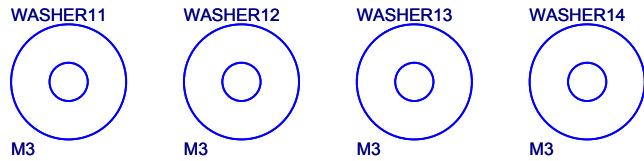
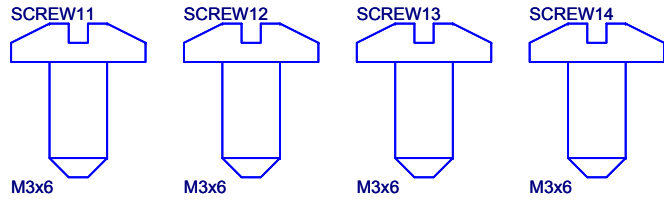

TAS5631 Parts list 2.00



AUDIO/IMAGING GROUP
Home Audio Amplifiers
ALL RIGHTS RESERVED
TEXAS INSTRUMENTS INCORPORATED

Project: TAS5631DKD2EVM	Rev: 2.00
Page Title: Mechanics	Size: A4
File Name: A853-SCH-001.DSN	Engineer: JLH & JSV
Date: Monday, August 24, 2009	Page: 5 of 5

Qty	Part Reference	Description	Manufacture	First Mfr P/N
1	R41	0R / 5% / 0603 Thick Film Resistor	Yageo	RC0603JR-070RL
4	R100 R101 R104 R112	100R / 100mW / 5% / 0603 Thick Film Resistor	Yageo	RC0603JR-07100RL
16	R65 R66 R68 R69 R70 R71 R76 R78 R79 R85 R86 R87 R88 R89 R90 R91	10k / 100mW / 5% / 0603 Thick Film Resistor	Yageo	RC0603JR-0710KL
1	R55	1M / 100mW / 5% / 0603 Thick Film Resistor	Yageo	RC0603JR-071ML
1	R48	1.2k / 100mW / 5% / 0603 Thick Film Resistor	Yageo	RC0603JR-071K2L
2	R103 R110	1.5R / 100mW / 5% / 0603 Thick Film Resistor	Yageo	RC0603JR-071R5L
1	R50	1.8k / 100mW / 5% / 0603 Thick Film Resistor	Yageo	RC0603JR-071K8L
2	R10 R54	200R / 100mW / 5% / 0603 Thick Film Resistor	Yageo	RC0603JR-07200RL
1	R16	24k / 100mW / 1% / 0603 Thick Film Resistor	Yageo	RC0603FR-0724KL
5	R61 R98 R111 R114 R115	3.3R / 100mW / 5% / 0603 Thick Film Resistor	Yageo	RC0603JR-073R3L
3	R43 R45 R46	4.7k / 100mW / 5% / 0603 Thick Film Resistor	Yageo	RC0603JR-074K7L
1	R116	47k / 100mW / 5% / 0603 Thick Film Resistor	Yageo	RC0603JR-0747KL
1	R62	4.7R / 100mW / 5% / 0603 Thick Film Resistor	Yageo	RC0603JR-074R7L
20	R40 R51 R52 R59 R64 R67 R72 R73 R74 R75 R77 R80 R81 R82 R83 R84 R92 R93 R94 R95	47R / 100mW / 5% / 0603 Thick Film Resistor	Yageo	RC0603JR-0747RL
1	R47	560R / 100mW / 5% / 0603 Thick Film Resistor	Yageo	RC0603JR-07560RL
5	C60 C95 C107 C112 C116	Ceramic 10nF / 100V / 20% X7R 0805 Capacitor	BC Components	0805B103M101NT
4	C93 C96 C115 C117	Ceramic 1nF / 100V / 10% NP0 1206 Capacitor	BC Components	1206N102K101NT
5	C50 C103 C104 C111 C118	Ceramic 2.2uF / 100V / 20% X7R 1210 Capacitor	Murata	GRM32ER72A225KA35L
2	C10 C68	Ceramic 10nF / 50V / 20% X7R 0603 Capacitor	Vishay	VJ0603Y103MXA
18	C16 C54 C56 C64 C65 C67 C69 C86 C87 C88 C91 C92 C97 C98 C99 C102 C151 C152	Ceramic 100nF / 16V / 20% X7R 0603 Capacitor	Vishay	VJ0603Y104MXJ
8	C70 C71 C74 C79 C82 C83 C84 C85	Ceramic 220nF / 16V / 20% X7R 0603 Capacitor	BC Components	VJ0603Y224MXJ
4	C58 C59 C94 C110	Ceramic 33nF / 25V / 20% X7R 0603 Capacitor	BC Components	0603B333M250NT
1	C15	Ceramic 4.7nF / 50V / 20% X7R 0603 Capacitor	BC Components	0603B472M500NT
2	C14 C100	Ceramic 4.7uF / 6.3V / 20% X5R 0603 Capacitor	Panasonic	ECJ-1V50J475M
1	C90	Ceramic 100pF / 50V / 10% NP0 0603 Capacitor	BC Components	0603N101K500NT
1	C81	Ceramic 1nF / 50V / 10% NP0 0603 Capacitor	BC Components	0603N102K500NT
2	C77 C78	Ceramic 15pF / 50V / 10% NP0 0603 Capacitor	BC Components	0603N150K500NT
4	C72 C73 C113 C114	Metal Film 680nF / 250V / 20% Polypropylene 15mm (W:8mm L:18mm) Capacitor	Wima	MKP 4 0.68uF/20%/250Vdc PCM15
2	C53 C55	Electrolytic 10uF / 16V / 20% Aluminium 2mm ø5mm M Series - General Purpose Capacitor	Panasonic	ECA1CM100
4	C51 C105 C106 C109	Electrolytic 1000uF / 63V / 20% Aluminium 7.5mm ø16mm FC Series - Low Impedance Capacitor	Panasonic	EEUFC1J102
1	C108	Electrolytic 47uF / 63V / 20% Aluminium 5mm ø10mm Capacitor	BC Components	2222 136 68479
4	C89 C101 C150 C153	Electrolytic 47uF / 16V / 20% Aluminium 2mm ø5mm FC Series - Low Impedance Capacitor	Panasonic	EEUFC1C470
4	C66 C75 C76 C80	Electrolytic 82uF / 16V / 20% Aluminium 2mm ø5mm FC Series - Low Impedance Capacitor	Panasonic	EEUFC1C820
4	L15 L16 L17 L18	10uH / Ferrite Inductor	Toko	C3B-A0336



3	D13 D14 D16	Light Emitting Red Red LED (0603)	Toshiba	TLSU1008
1	D11	Light Emitting Green Green LED (0603)	Toshiba	TLGU1008
3	Q11 Q13 Q16	0.115A / 60V N-ch Power 2N7002 Mosfet (SOT-23)	Fairchild	2N7002
1	U10	TAS5518C / 8 ch PWM processor (AD, DAP, 192kHz, PWM-VOL) (TQFP64)	Texas Instruments	TAS5518CPAG
1	U14	TAS5631DKD / 300 W STEREO FEEDBACK DIGITAL AMPLIFIER (PSOP3-44)	Texas Instruments	TAS5631DKD
1	U15	SN74LVC1G08 / Single AND gate, LVC (SOT23-5)	Texas Instruments	SN74LVC1G08DBVR
1	U150	TPS3825-33 / 3.3V Supply Voltage Supervisor (SOP5-DBV)	Texas Instruments	TPS3825-33DBVT
1	U13	LM317 / 0.5A Positive Adjustable Regulator (DCY)	Texas Instruments	LM317MDCY
1	U151	TLV1117-33C / 3.3V/800mA Positive Voltage Regulator (SOT4-DCY)	Texas Instruments	TLV1117-33CDCYR
6	SCREW11 SCREW12 SCREW13 SCREW14 SCREW15 SCREW16	M3x6 Pan Head, Pozidriv, A2 Screw	Bossard	BN 81882 M3x6
2	WASHER20 WASHER21 WASHER11 WASHER12 WASHER13 WASHER14 WASHER15 WASHER16	M3 White Nylon (o/d:9.0 i/d:3.2 t:0.8) Washer	Bossard	BN1075 M3
6	STANDOFF11 STANDOFF12 STANDOFF13 STANDOFF14	M3 Stainless Steel Spring Washer	Bossard	BN 760 M3
4	STANDOFF11 STANDOFF12 STANDOFF13 STANDOFF14	M3x16 nickel plated brass Stand-off	Bossard	BN 3320 M3x16
1	J22	2 pins / 1 row / 2.54mm Pitch Vertical Male Friction lock Pin header Header	Molex	22-27-2021
1	J10	26 pins / 2 rows / 2.54mm Pitch Vertical Male Low profile IDC 26 pins IDC Box header	Molex	87834-2611
3	J12 J14 J15	2 pins / Vertical Female Banana Red and black banana socket	Cliff	TPP-3CT
1	X10	13.5MHz 13.5MHz SMD Crystal (HCM49)	Citizen	HCM49-13.500MABJT
3	SW1 SW2 SW3	Switch DPDT PCB Mount Switch	NKK-Nikkai	G-22-AP
1	PCB11	A853-PCB-001_2.00 / TAS5631DKD2EVM Printed Circuit Board (ver. 2.00)	Printline	A853-PCB-001(2.00)
1	HEATSINK11	TIC-HSINK-061_2.00 / Heatsink for 1 DKD44 package, length 78 mm	Phonotech	TIC-HSINK-061(2.00)

TAS5631DKD2EVM

PCB SPECIFICATION

Version 2.00

BOARD IDENTIFICATION:	A853-PCB-001(2.00)
BOARD TYPE:	DOUBLE-SIDED PLATED-THROUGH BOARD
LAMINATE TYPE:	FR4
LAMINATE THICKNESS:	1.6mm
TOP LAYER COPPER THICKNESS:	70 μ m (INCL. PLATING EXTERIOR LAYER)
BOTTOM LAYER COPPER THICKNESS:	70 μ m (INCL. PLATING EXTERIOR LAYER)
COPPER PLATING OF HOLES:	>25 μ m
MINIMUM HOLE DIAMETER	0.3 mm
SILKSCREEN COMPONENT SIDE:	WHITE - REMOVE SILKSCREEN FROM SOLDER AREA & PRE-TINNED AREAS
SILKSCREEN SOLDER SIDE:	None
SOLDER MASK COMPONENT SIDE:	GREEN
SOLDER MASK SOLDER SIDE:	GREEN
PROTECTIVE COATING:	SOLDER COATING AND CHEMICAL SILVER ON FREE COPPER
ELECTRICAL TEST:	PCB MUST BE ELECTRICAL TESTED
MANUFACTURED TO:	PERFAG 2E (www.perfag.dk)
APERTURE TABLE:	PERFAG 10A (www.perfag.dk)
BOARD SIZE:	95 x 140 mm
Aprox. Number of holes	420
COMMENTS:	SEE DRILL INFORMATION FILE (A853-PCB-001(2.00).pdf)

COMPONENT SIDE	Dps 5349 090818
TI Denmark A853-PCB-001 (2.00)	

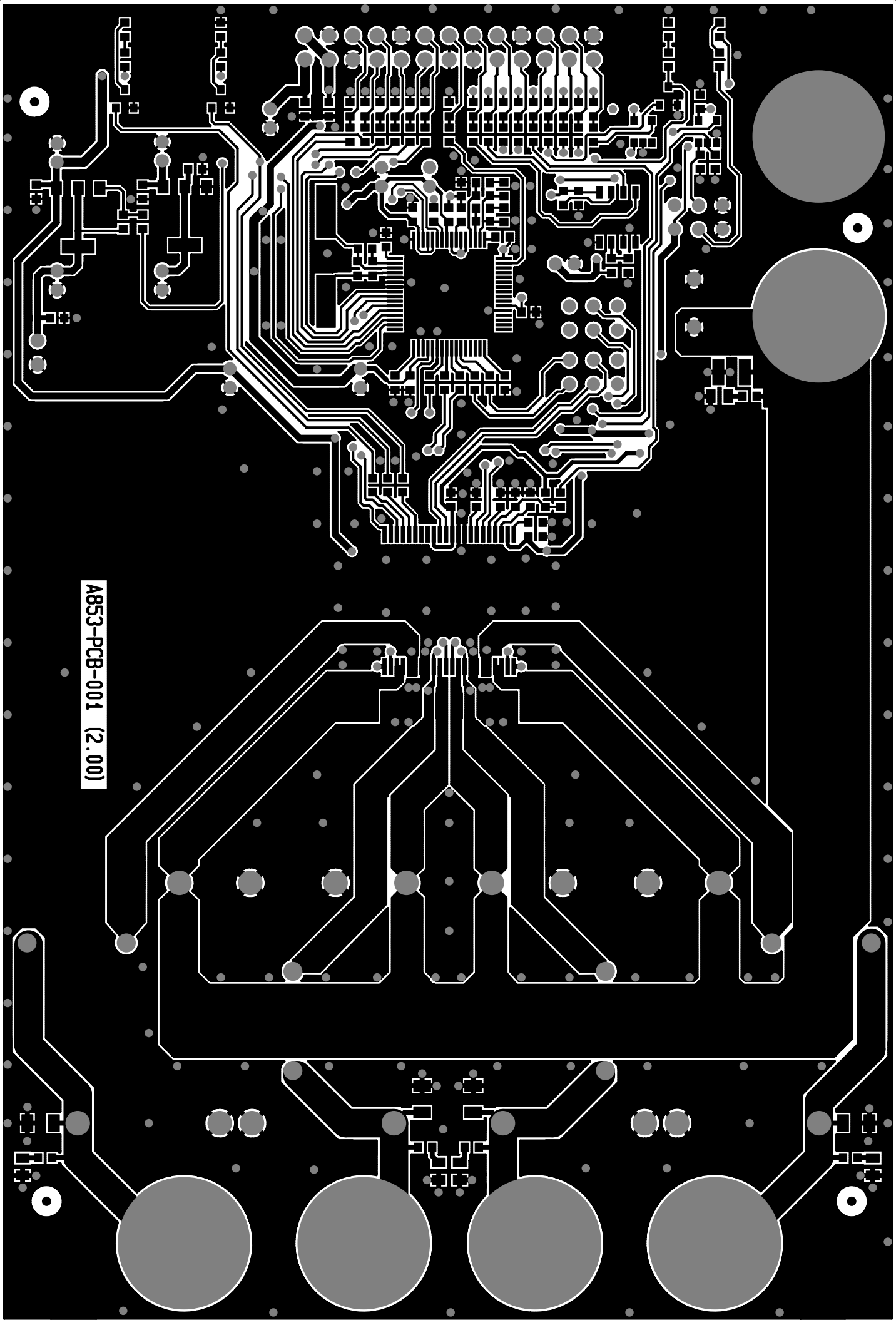

COMPONENT LAYOUTS ICOMP	DpS 5349 090818
TI Denmark A853-PCB-001 (2.00)	

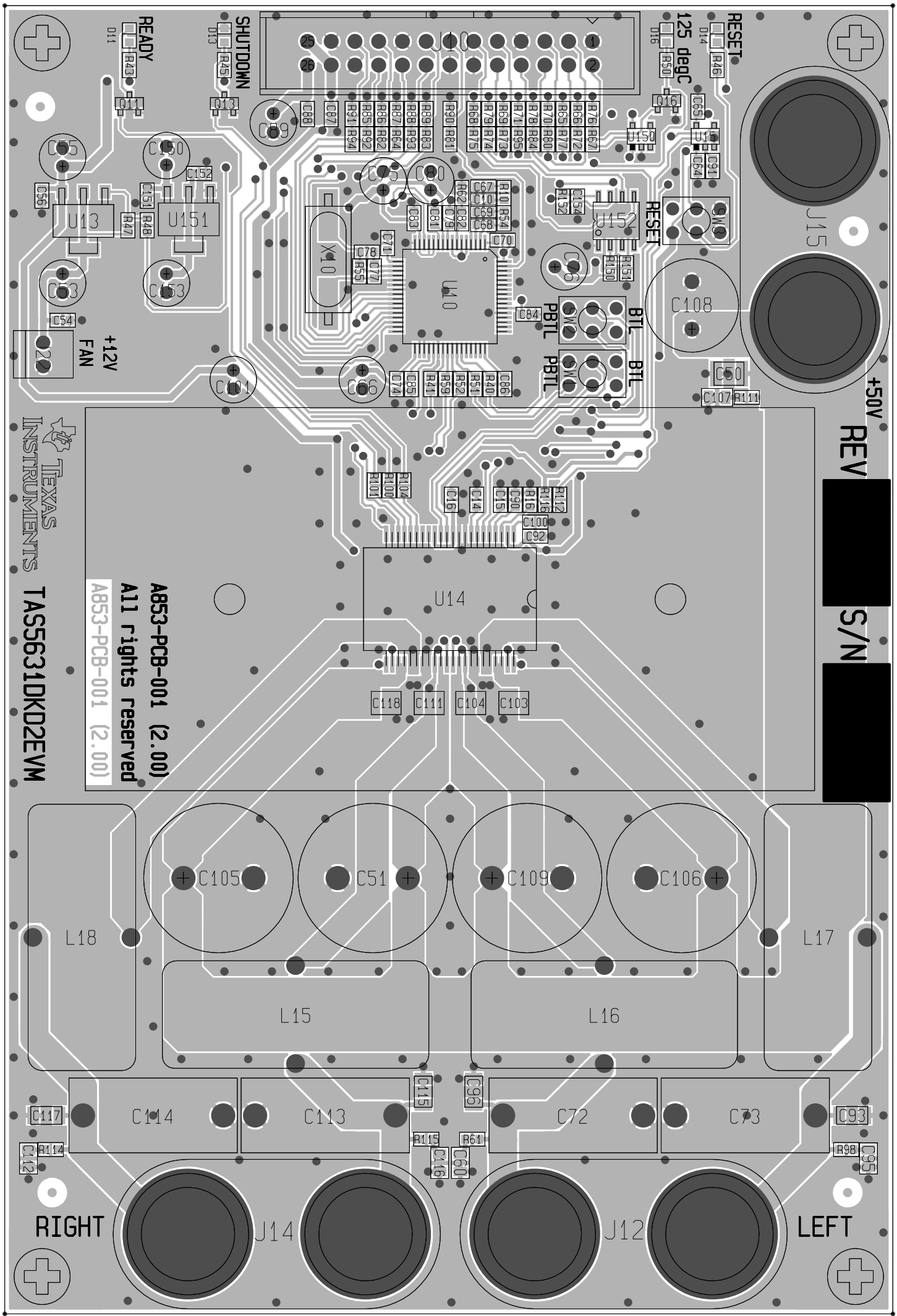

818090 2432 2q0	2012 930J02
TI Dgnmark A823-PCB-001 (S.00)	

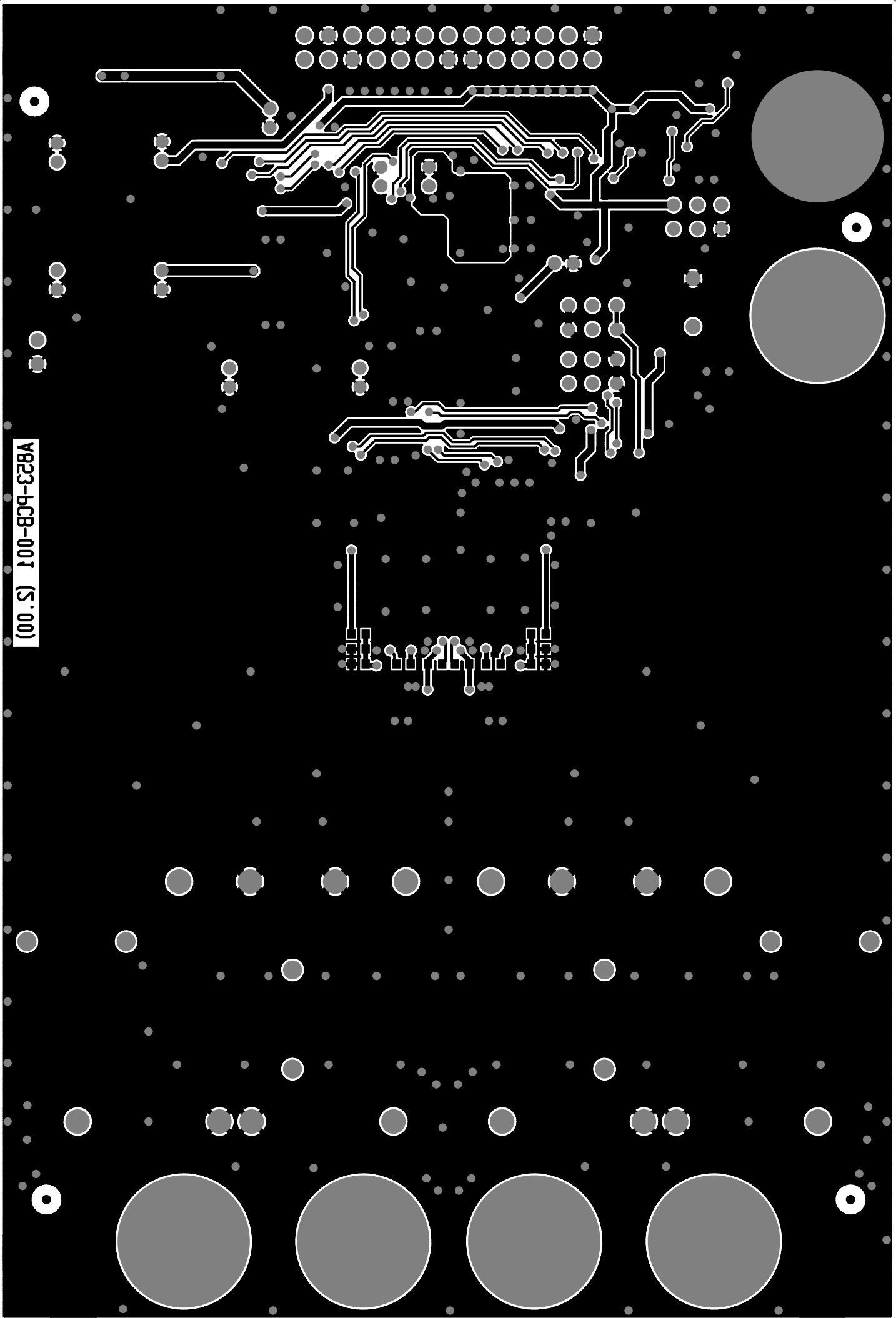

TI Dgumark A823-PCB-001 (S.00)	SILKSCREEN 20LD 0ps 234a 0a0818
--------------------------------	---------------------------------

ATT Lrghts L629L69
A823-PCB-001 (S.00)

STIMULI
SAYET
JEXX2



R110
C105
C87
C110 C28 C84 C29
C88
R103
C89

+

+

+

+

TI Dgumark A823-PCB-001 (S.00)
COMP. LAYOUT 20LD 0b2 2342 020818

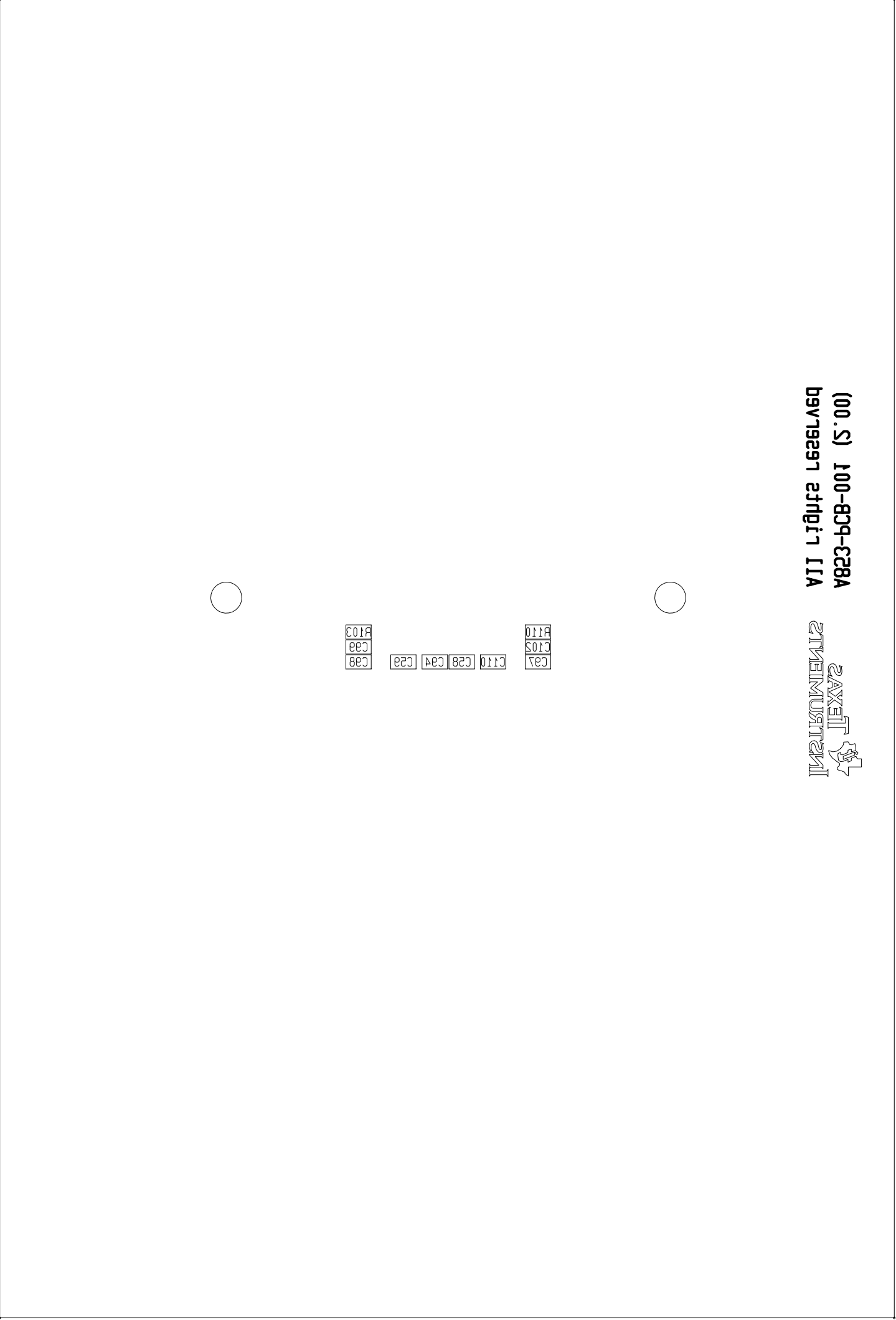

ATT Lrghtz L626LV69
A823-PCB-001 (S.00)



Ca2 C110 C28 Ca4 C29
Ca8 Ca9 P103
Ca2 C105 P110

TI Dgnmark A823-PCB-001 (S.00)
COMPERLAYOUT 2010 02 23 09 020818

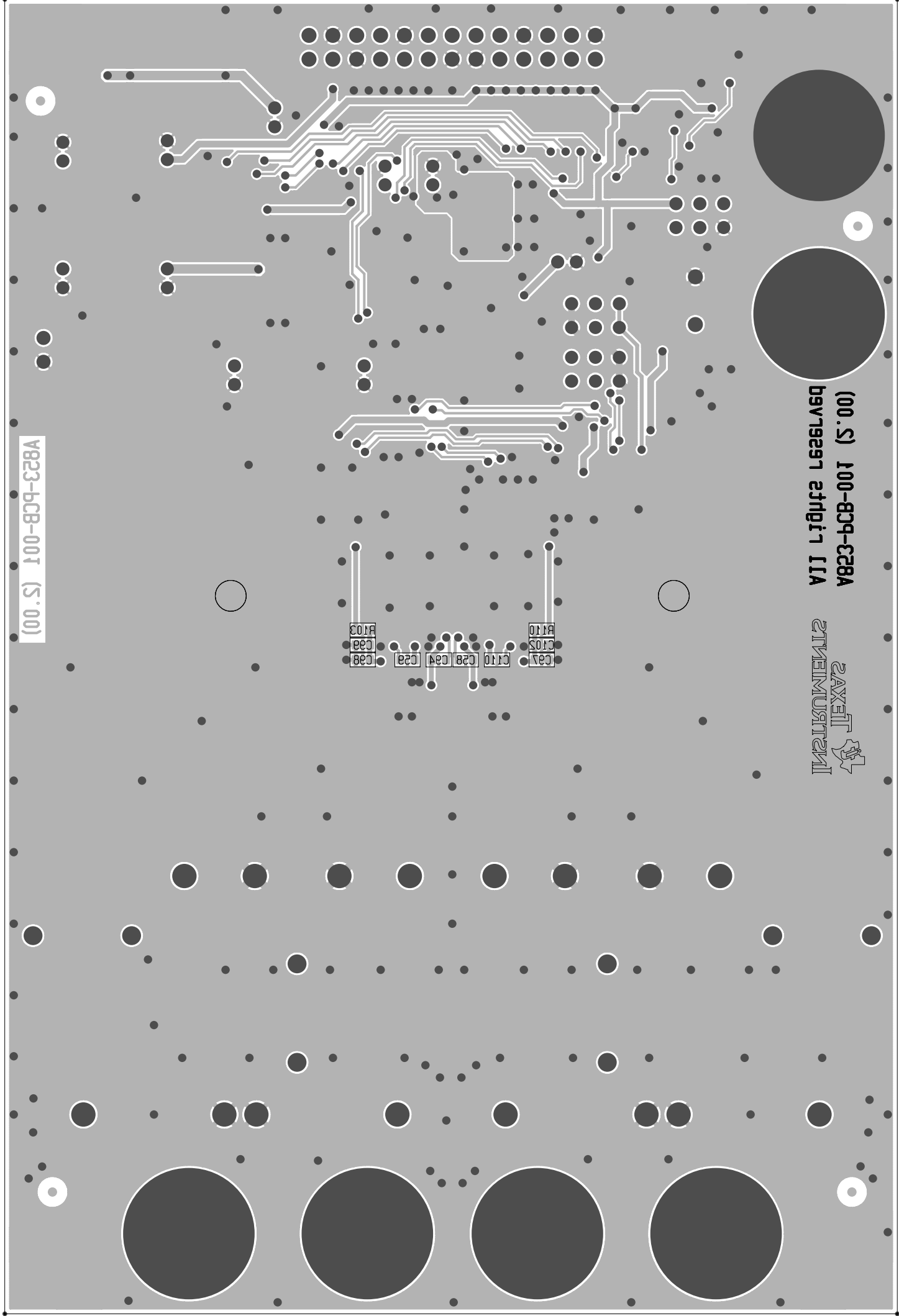

A823-PCB-001 (S.00)

TI Dgnmark A823-PCB-001 (S.00)



TIC-HSINK-061 (2.00)

Heat sink for 1 DKD44 package

8.July 2008
TIC-HSINK-061 (2.00).dwg

Jonas L. Holm

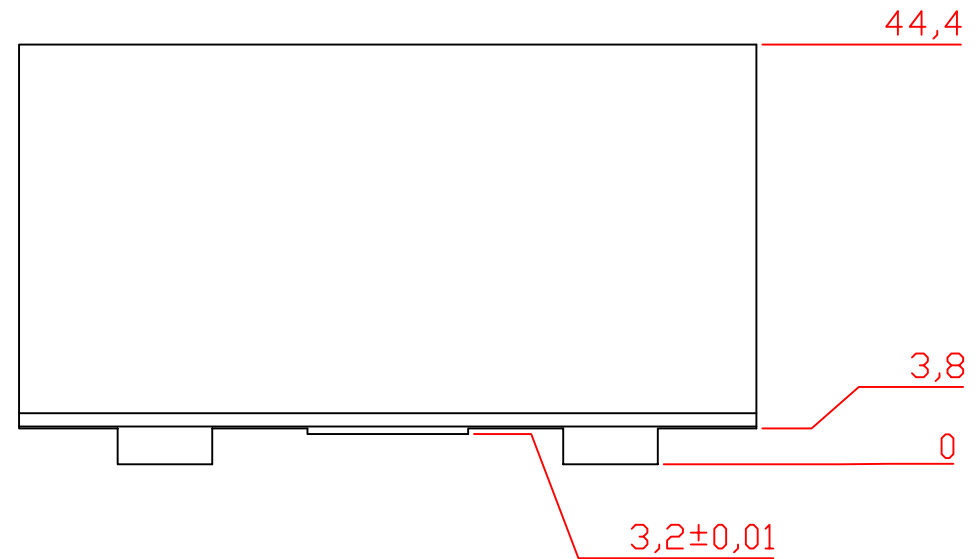
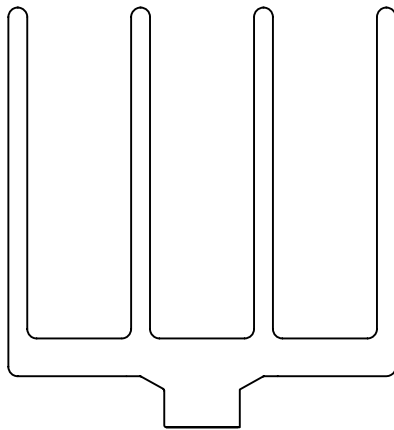
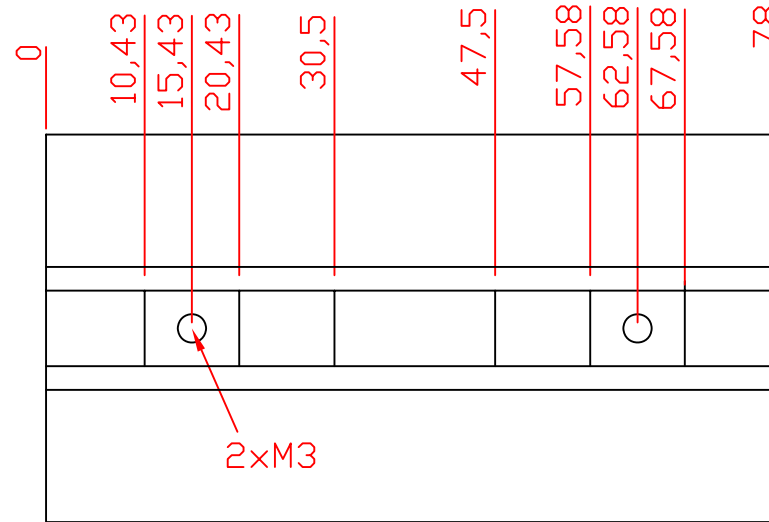

APPROX. SCALE: 1.25:1

DIMENSIONS: mm

MATERIAL: Profile TIC-HSINK-050(1.00), ALUMINUM

SURFACE: FREE OF SHARP EDGES

SURFACE TREATMENT: BLACK ANODIZED

TOLERANCES: +/- 0.1 mm