

(Place all components within this block close together)

+1.538V @ 2A Max

$$(V_{OUT} = 0.8 \times (1 + R1/R2))$$

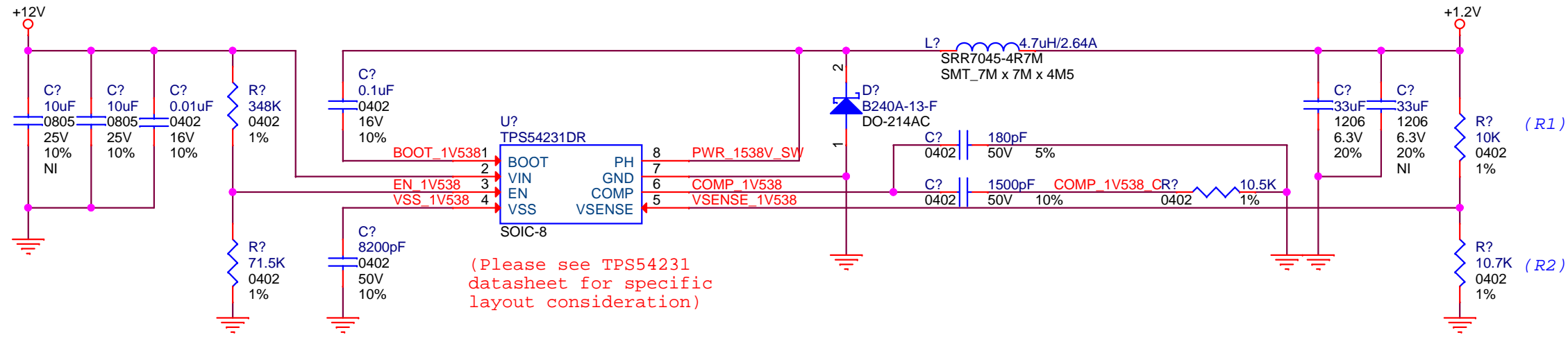

(Please see TPS54231 datasheet for specific layout consideration)

(Place all components within this block close together)

+1.2V @ 2A Max

$$(V_{OUT} = 0.8 \times (1 + R1/R2))$$

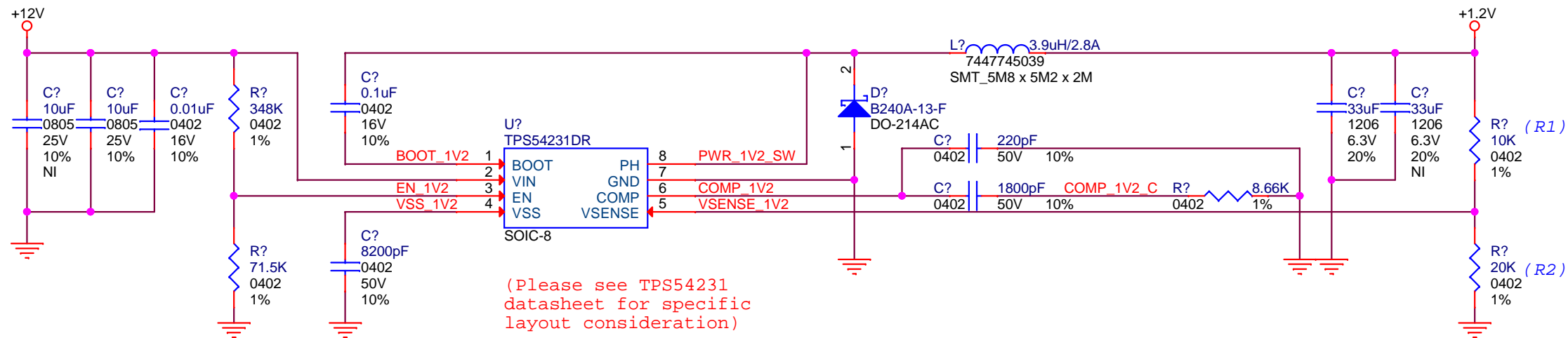

(Please see TPS54231 datasheet for specific layout consideration)