

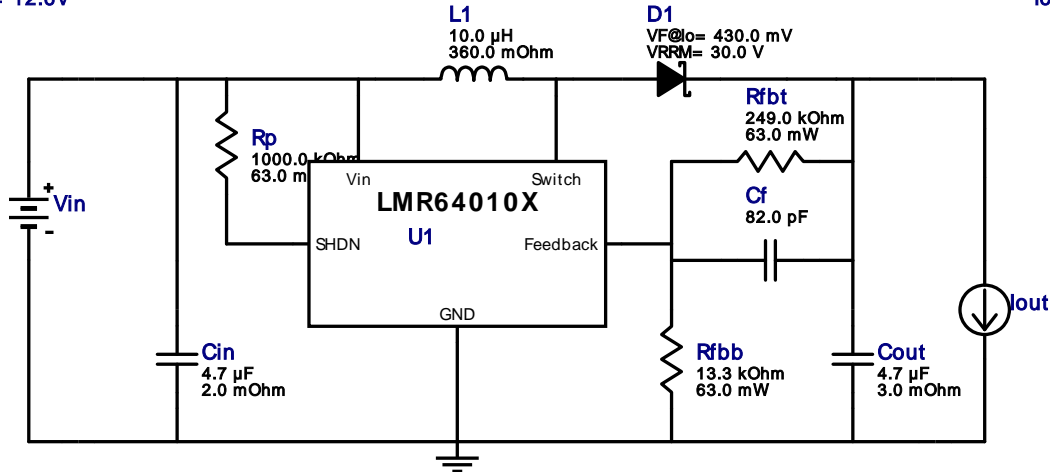









**WEBENCH® Design Report**

 Design : 3979678/17 LMR64010XMF/NOPB  
 LMR64010XMF/NOPB 11.4V-12.6V to 24.0V @ 0.03A

**VinMax = 12.6V**
**Iout = 0.03A**

**Electrical BOM**

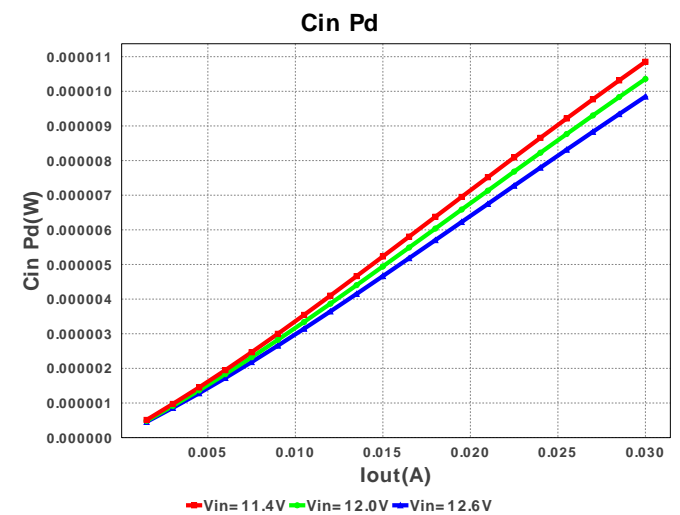
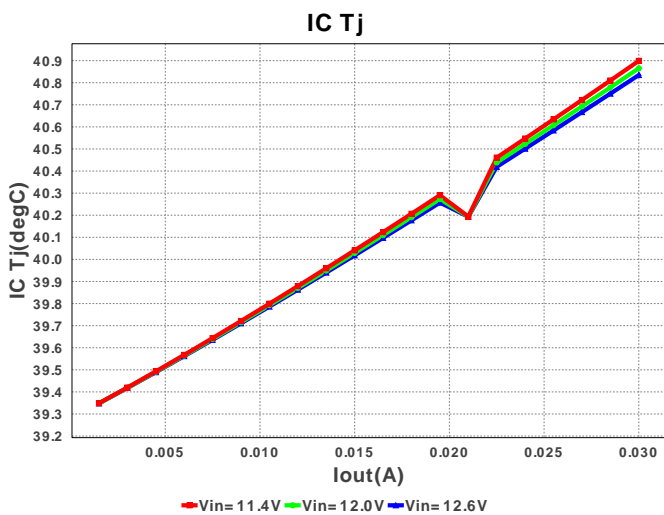
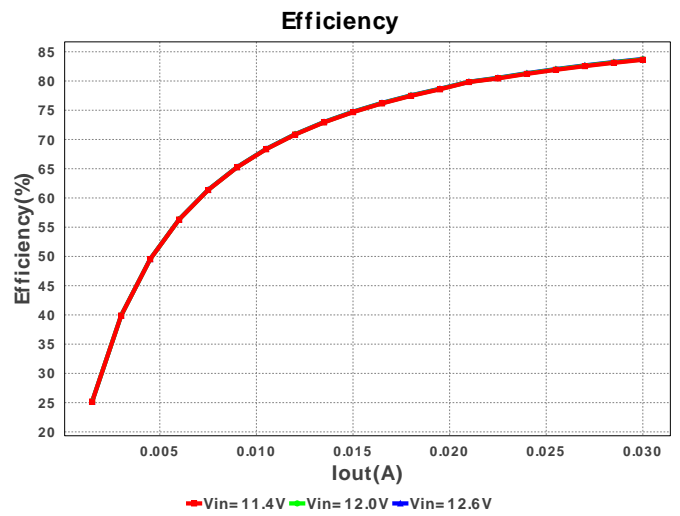
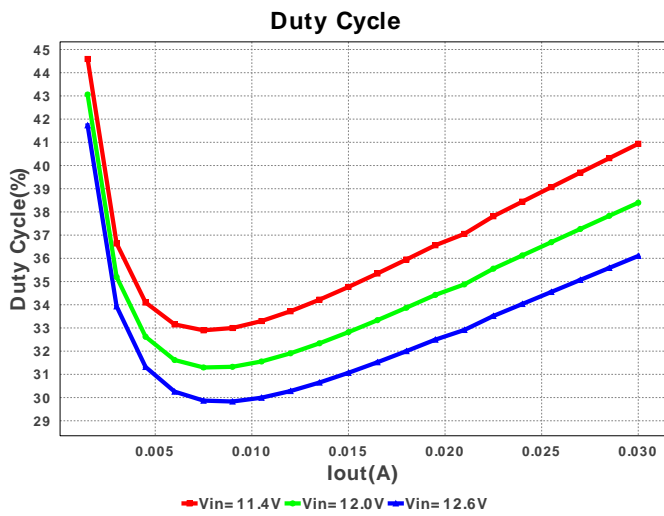
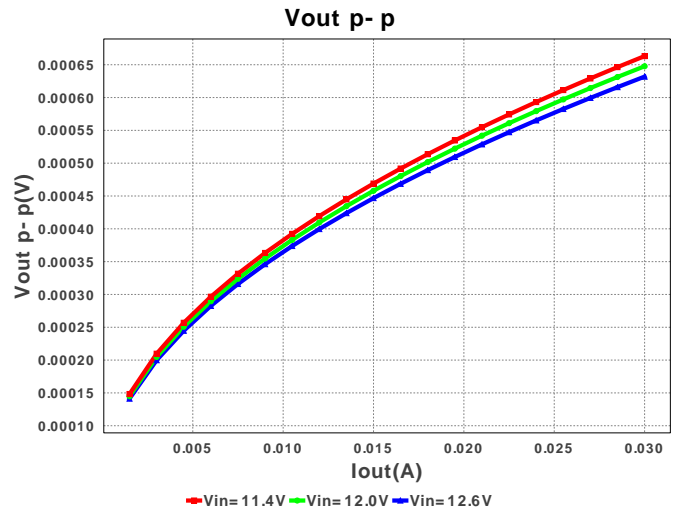
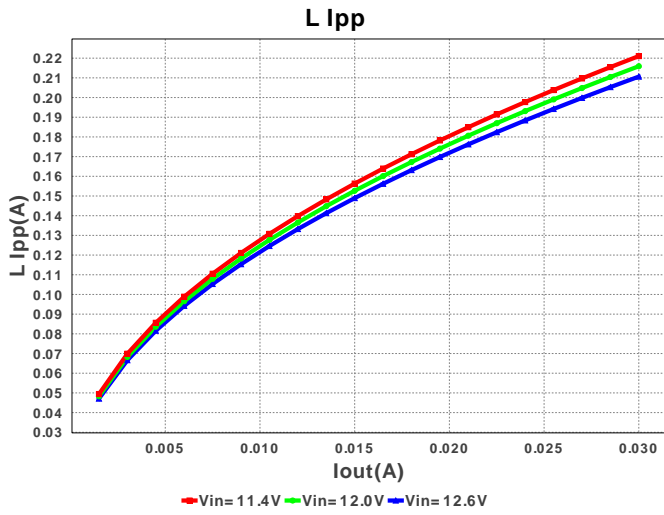
#	Name	Manufacturer	Part Number	Properties	Qty	Price	Footprint
1.	Cf	Yageo America	CC0805JRNPO9BN820 Series= C0G/NP0	Cap= 82.0 pF VDC= 50.0 V IRMS= 0.0 A	1	\$0.01	 0805 7mm2
2.	Cin	MuRata	GRM21BR61E475MA12L Series= X5R	Cap= 4.7 uF ESR= 2.0 mOhm VDC= 25.0 V IRMS= 7.29 A	1	\$0.06	 0805 7mm2
3.	Cout	MuRata	GRM31CR71H475KA12L Series= X7R	Cap= 4.7 uF ESR= 3.0 mOhm VDC= 50.0 V IRMS= 4.98 A	1	\$0.10	 1206 11mm2
4.	D1	ON Semiconductor	MBR0530T1G	VF@Io= 430.0 mV VRRM= 30.0 V	1	\$0.06	 SOD-123 13mm2
5.	L1	Taiyo Yuden	CBC2518T100M	L= 10.0 uH DCR= 360.0 mOhm	1	\$0.05	 CBC2518 10mm2
6.	Rfbb	Vishay-Dale	CRCW040213K3FKED Series= CRCW..e3	Res= 13.3 kOhm Power= 63.0 mW Tolerance= 1.0%	1	\$0.01	 0402 3mm2
7.	Rfbt	Vishay-Dale	CRCW0402249KFKED Series= CRCW..e3	Res= 249.0 kOhm Power= 63.0 mW Tolerance= 1.0%	1	\$0.01	 0402 3mm2
8.	Rp	Vishay-Dale	CRCW04021M00FKED Series= CRCW..e3	Res= 1000.0 kOhm Power= 63.0 mW Tolerance= 1.0%	1	\$0.01	 0402 3mm2
9.	U1	Texas Instruments	LMR64010XMF/NOPB	Switcher	1	\$0.60	 MF05A 15mm2

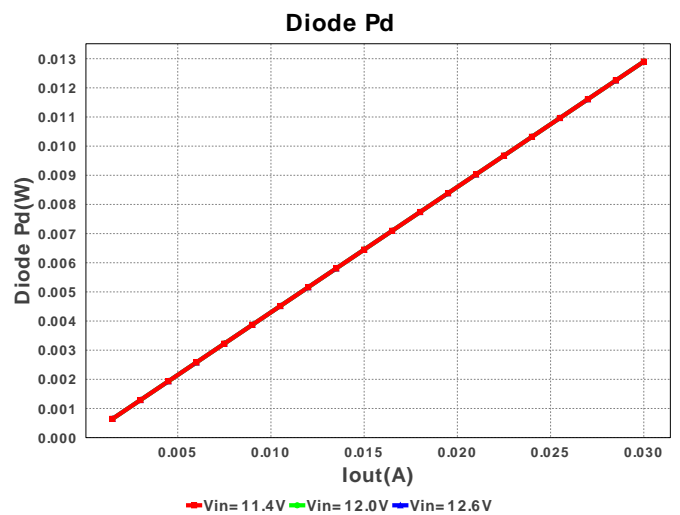
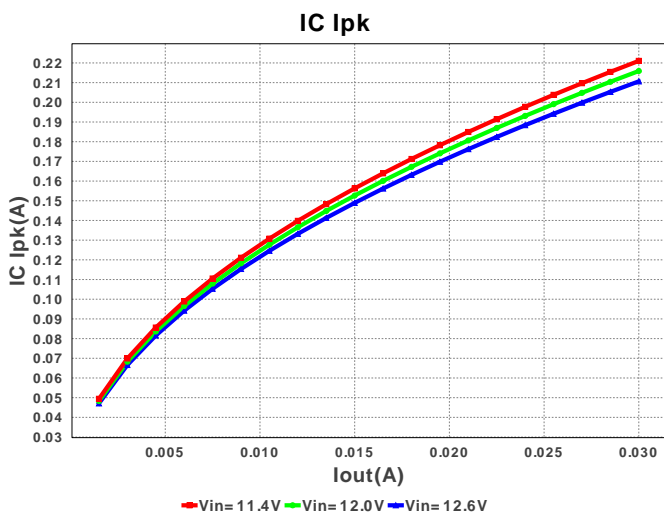
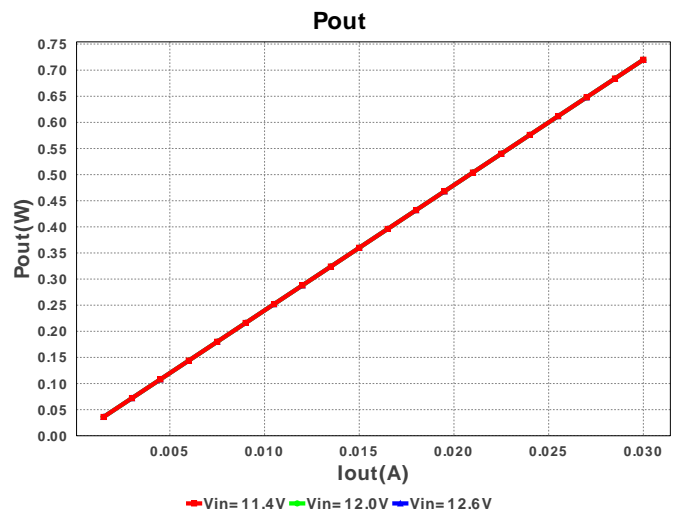
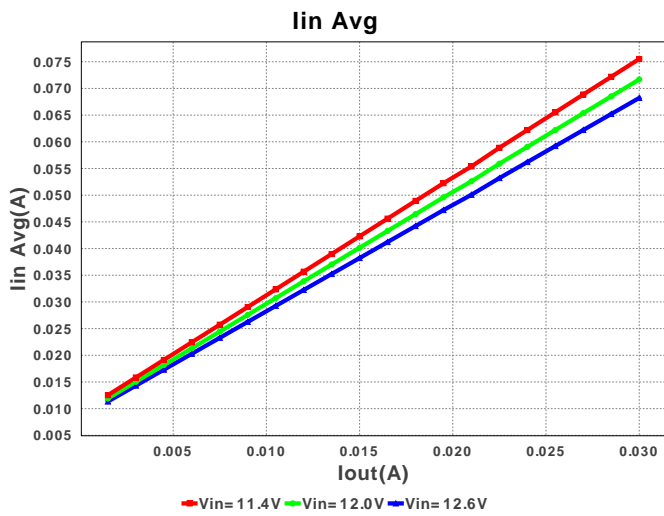
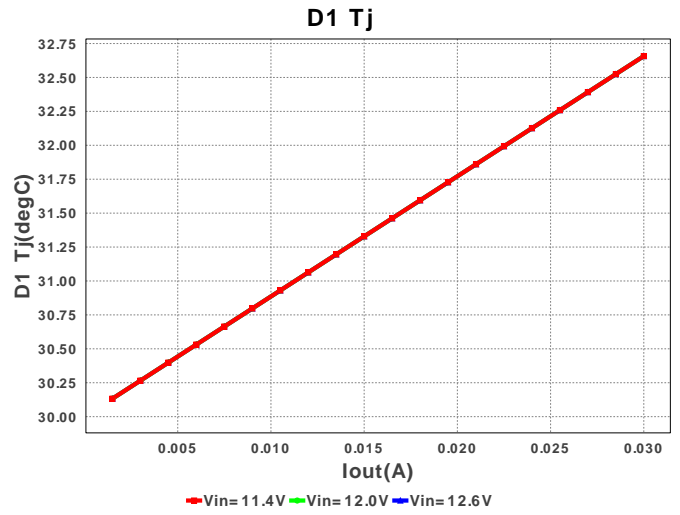
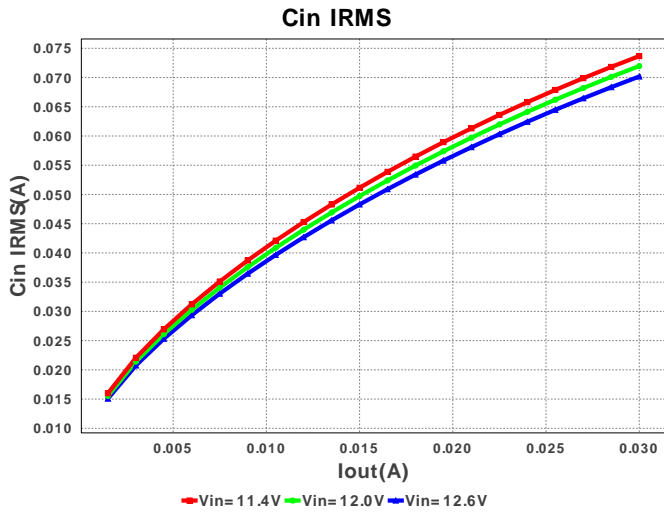

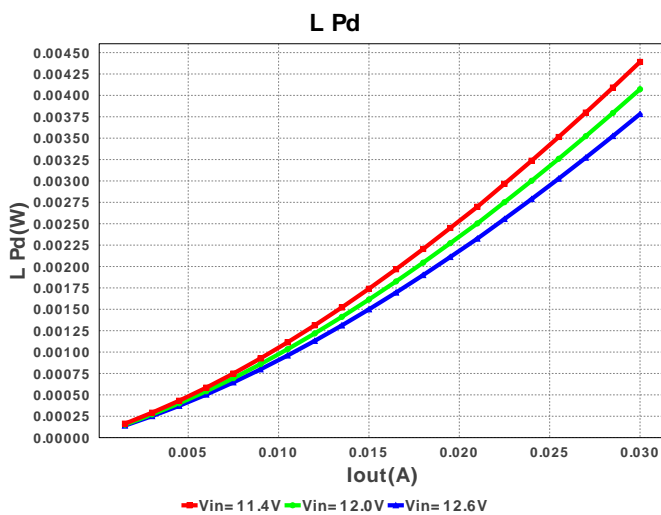
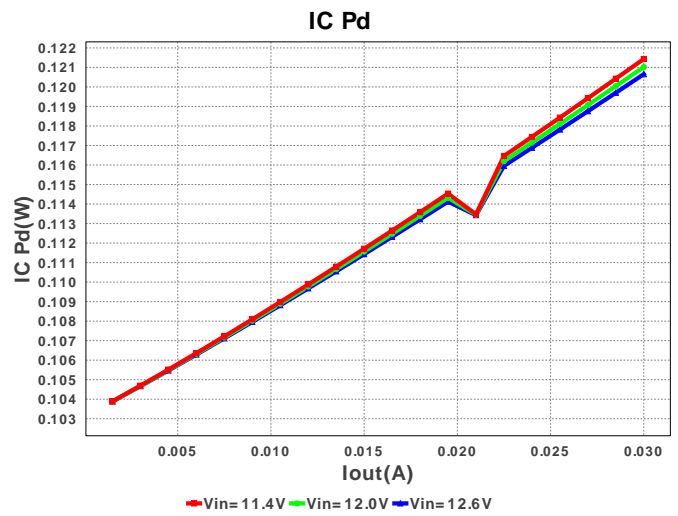
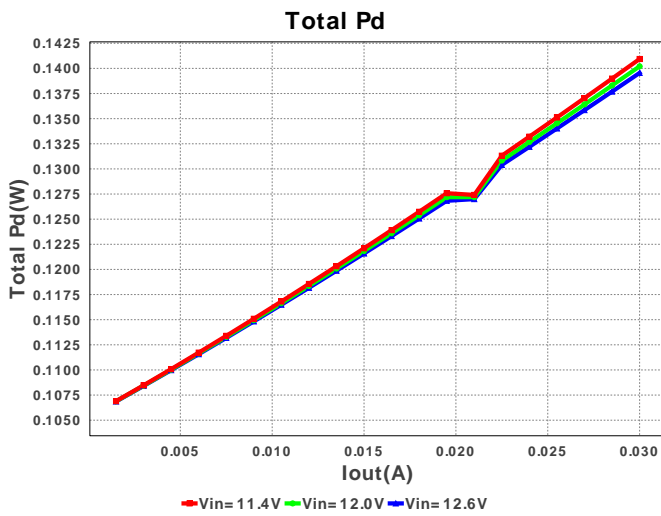
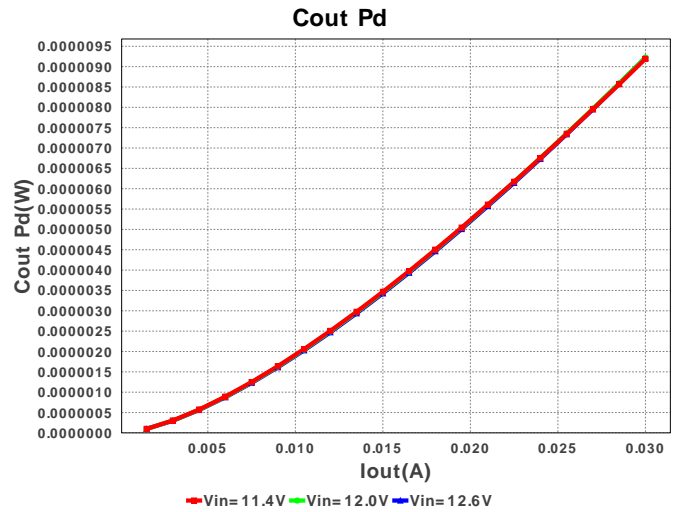
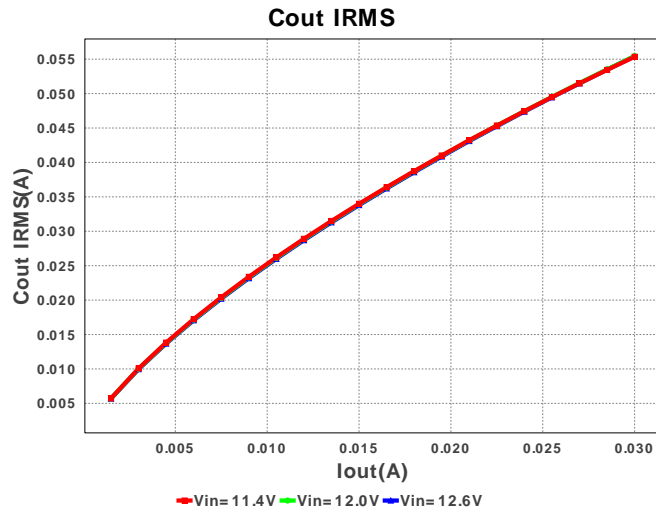



### Operating Values

#	Name	Value	Category	Description
1.	Cin IRMS	73.666 mA	Current	Input capacitor RMS ripple current
2.	Cout IRMS	55.35 mA	Current	Output capacitor RMS ripple current
3.	IC Ipk	221.049 mA	Current	Peak switch current in IC
4.	Iin Avg	75.521 mA	Current	Average input current
5.	L Ipp	221.049 mA	Current	Peak-to-peak inductor ripple current
6.	BOM Count	9	General	Total Design BOM count
7.	FootPrint	71.0 mm <sup>2</sup>	General	Total Foot Print Area of BOM components
8.	Frequency	1.6 MHz	General	Switching frequency
9.	Pout	720.0 mW	General	Total output power
10.	Total BOM	\$0.91	General	Total BOM Cost
11.	D1 Tj	32.657 degC	Op_Point	D1 junction temperature

#	Name	Value	Category	Description
12.	Duty Cycle	40.936 %	Op_point	Duty cycle
13.	Efficiency	83.63 %	Op_point	Steady state efficiency
14.	IC Tj	40.899 degC	Op_point	IC junction temperature
15.	IOUT_OP	30.0 mA	Op_point	Iout operating point
16.	VIN_OP	11.4 V	Op_point	Vin operating point
17.	Vout p-p	663.146 $\mu$ V	Op_point	Peak-to-peak output ripple voltage
18.	Cin Pd	10.853 $\mu$ W	Power	Input capacitor power dissipation
19.	Cout Pd	9.191 $\mu$ W	Power	Output capacitor power dissipation
20.	Diode Pd	12.9 mW	Power	Diode power dissipation
21.	IC Pd	121.433 mW	Power	IC power dissipation
22.	L Pd	4.391 mW	Power	Inductor power dissipation
23.	Total Pd	140.936 mW	Power	Total Power Dissipation

## Design Inputs

#	Name	Value	Description
1.	Iout	30.0 mA	Maximum Output Current
2.	Iout1	30.0 mAmps	Output Current #1
3.	VinMax	12.6 V	Maximum input voltage
4.	VinMin	11.4 V	Minimum input voltage
5.	Vout	24.0 V	Output Voltage
6.	Vout1	24.0 Volt	Output Voltage #1
7.	base_pn	LMR64010X	Base Product Number
8.	source	DC	Input Source Type
9.	Ta	30.0 degC	Ambient temperature

## Design Assistance

1. Application Hints WEBENCH ThetaJA Value The 90degC/W ThetaJA value displayed in WEBENCH is a measured value taken from the Demo Board, which utilizes a 4-layer PCB.

2. **LMR64010X** Product Folder : <http://www.ti.com/product/lmr64010> : contains the data sheet and other resources.

Texas Instruments' WEBENCH simulation tools attempt to recreate the performance of a substantially equivalent physical implementation of the design. Simulations are created using Texas Instruments' published specifications as well as the published specifications of other device manufacturers. While Texas Instruments does update this information periodically, this information may not be current at the time the simulation is built. Texas Instruments does not warrant the accuracy or completeness of the specifications or any information contained therein. Texas Instruments does not warrant that any designs or recommended parts will meet the specifications you entered, will be suitable for your application or fit for any particular purpose, or will operate as shown in the simulation in a physical implementation. Texas Instruments does not warrant that the designs are production worthy.

**You should completely validate and test your design implementation to confirm the system functionality for your application prior to production.**

Use of Texas Instruments' WEBENCH simulation tools is subject to [Texas Instruments' Site Terms and Conditions of Use](#). Prototype boards based on WEBENCH created designs are provided AS IS without warranty of any kind for evaluation and testing purposes and are subject to the terms of the [Evaluation License Agreement](#).