

Designing LED Backlight Drivers for Media Form Factor Displays

White LEDs (WLEDs) have long been the choice for backlighting small LCD displays, such as those used in mobile phones. With continuing performance improvements and cost reductions, LEDs have quickly moved into larger media form factor (MFF) displays, replacing Cold Cathode Fluorescent Lamps (CCFL) for LCD back (edge or side)-lighting. MFF displays up to 19" may require up to 100 LEDs for proper backlighting. Determining whether these LEDs should be configured in series or parallel requires collaboration between both the panel maker and the LED backlight driver manufacturer. In addition, how to implement dimming is critical design decision where power efficiency, display quality, and cost all need to be analyzed and compromised.

This article provides guidance on how to choose the best WLED backlight solution, from LED configurations to dimming methods.

Why are WLEDs replacing CCFL in MFF displays?

The shift away from CCFL started with the European Union's RoHS initiative, which has sought to purge several toxic substances, including mercury, a major component in fluorescent lamps, from consumer products. While CCFL manufacturers continue to make performance improvements and reduce mercury levels in their relatively mature lamps, WLEDs have a distinct advantage in that they are a solid state device containing no mercury. WLEDs have a life cycle of 100,000h as compared to CCFLs around 60,000h. In addition, WLEDs that are based on a trio of narrowband red, green and blue (RGB) LEDs provide the best match for the RGB color filters of an LCD and can generate saturated colors very efficiently. While both CCFLs or WLEDs can be arranged uniformly over the back of an LCD panel, most are placed at the bottom of the display as shown in Figures 1a and 1b in yellow. For edge- or side-lighting applications, LEDs, with more directional lighting than the diffuse light of a fluorescent lamp, are more efficient at focusing the light. Therefore, when compared to a CCFL backlit panel, a WLED backlit panel requires a smaller light guide and diffuser for the same brightness level.

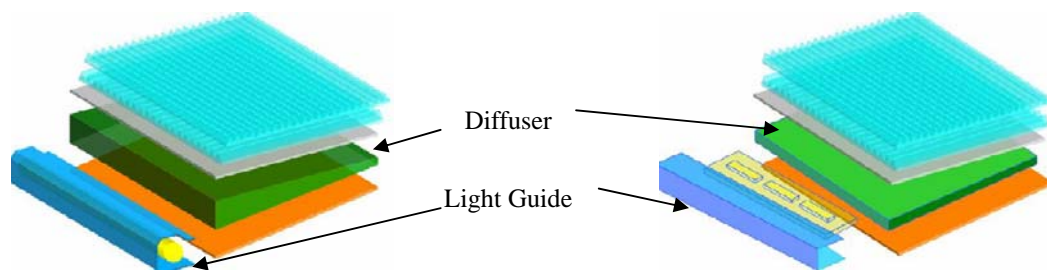

Figure 1a. CCFL backlit panel

Figure 1b WLED backlit panel

Figure 2 illustrates how the smaller light guide and diffuser results in a much thinner MFF display when it is backlit by WLEDs versus CCFL.



Figure 2 – LCD Panel thickness comparison

The power supply necessary to drive CCFLs is more complicated than one to drive WLEDs. Figure 3 shows a typical CCFL driver; a dc-to-ac inverter powered by an input voltage of 5 to 48 V dc.

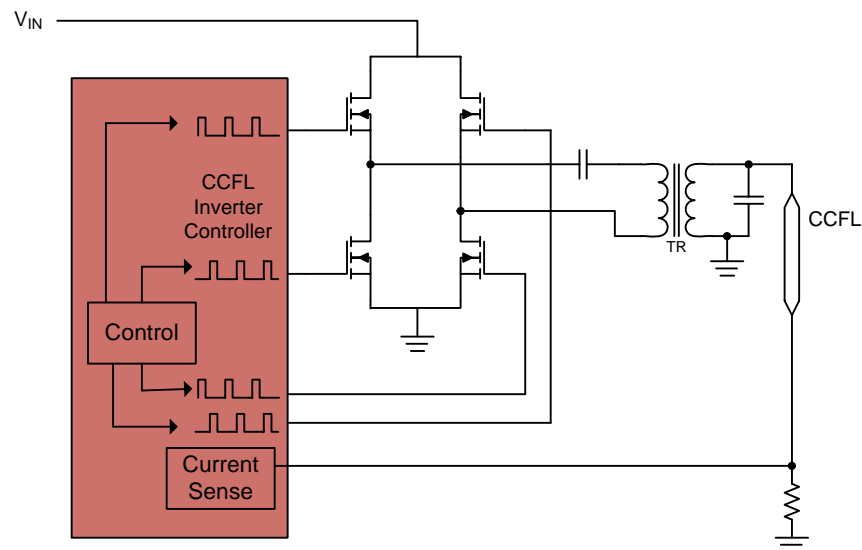

Figure 3– CCFL driver circuit diagram

A CCFL requires a typical “strike” or startup voltage of 1,500 and 1,600 Vac but

eventually settles down to 700 or 800 Vac and 3-8mA RMS to produce light. The CCFL strike voltage and time to brightness are inversely proportional to temperature. Due to the high voltages involved, various consumer product safety certifications are required. Therefore, the inverter designer must create a new, consumer-safe inverter for each lamp's specified range of strike voltages and startup times over the application's temperature range.

Driving WLEDs is much simpler. A WLED's brightness varies linearly with the current passing through it (at least until very low current levels). For the best WLED current accuracy and uniform WLED brightness per string, the driver should regulate current not voltage. Figure 4 shows how any adjustable dc/dc converter is easily re-configured as a constant current source to drive multiple WLEDs in series as long as its output is greater than the sum of the LEDs forward voltage (V_{LED}) drops.

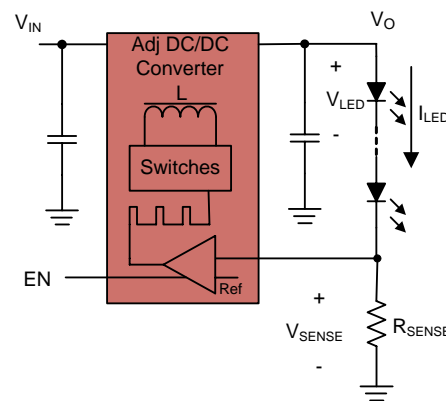

Figure 4 – Adjustable output converter providing constant current through a WLED string

By regulating V_{SENSE} , the voltage across the current sense resistor (R_{SENSE}) and not the output voltage (V_O), the driver is essentially a constant current source, leaving its output voltage (V_O) free to self-adjust for changes in V_{LED} with current and temperature. Because all WLED's brightness responds to changes in current in nanoseconds, much faster than the driver IC's response time, the WLED designer designs the converter startup time solely to optimize the driver's performance in the system, independent of the specific WLEDs being used. Lastly, the WLED driver designer rarely needs consumer certifications as few WLED backlight driver's power series WLEDs with a combined voltage above 50V.

An LCD display's dimming ratio is the ratio between the display's highest and lowest achievable brightness levels. Applications where the ambient lighting ranges from total darkness to bright daylight need panels with dimming ratio's greater than 10:1. Dimming circuitry for a WLED backlight is not only easier to implement but also provides better performance than comparable circuitry for a CCFL backlight. While both WLEDs and CCFLs operating characteristics vary with temperature, the CCFL lumens vary significantly and non-linearly with temperature changes, both ambient and self-generated. Therefore, the inverter designer faces significant changes

when designing either PWM or analog dimming circuitry to provide predictable brightness over a wide temperature range. Figure 5 illustrates how the lamp or LED current, and therefore the brightness, vary when using analog and PWM dimming.

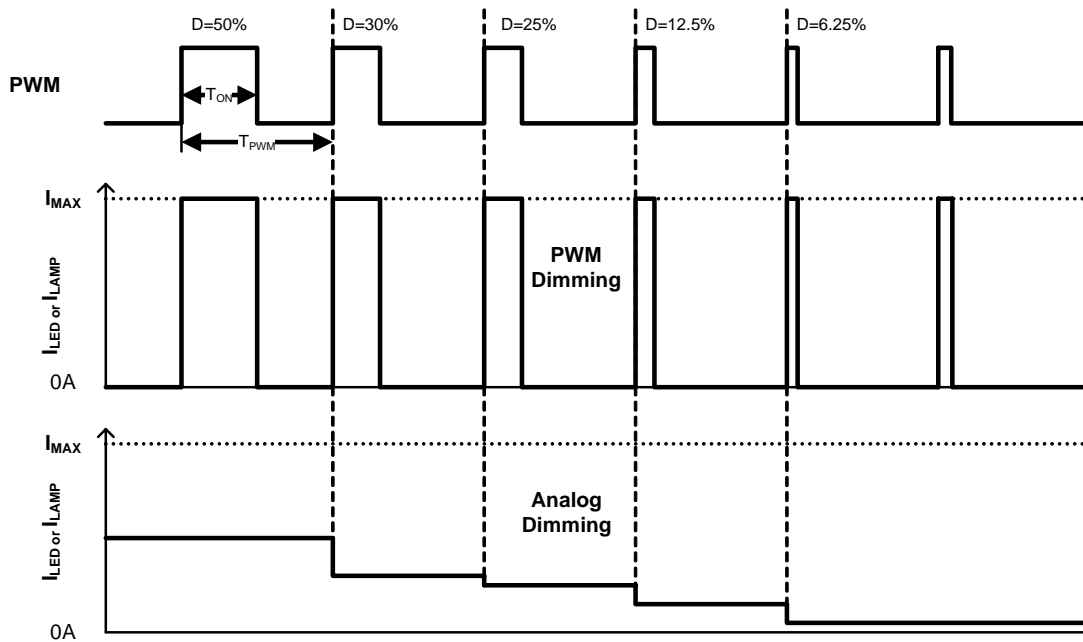

Figure 5 – Lamp or LED current when Analog and PWM dimming

With analog dimming, an external dc voltage applied to the CCFL inverter or WLED driver directly lowers current through, and the related brightness out of, the lamp or LED. A CCFL based backlight's minimum brightness might occur when the specified CCFL is operating at its specified minimum operating current, often 30% to 50% of the rated typical current. Thus a CCFL backlight display accomplishes a dimming ratio of only 2 or 3:1 or lower after the electrical losses of the CCFL assembly in larger displays are factored in. On the other hand, the minimum LED current and related brightness is only limited by the minimum voltage that can be regulated across R_{SENSE} either by lowering the internal reference voltage or by applying a practical external voltage. For example, a display with a WLED backlight configured as shown in figure 4 could easily achieve dimming ratios up to 40:1 by lowering the amplifier's feedback voltage from 200mV down to 5 mV. With PWM dimming, a PWM signal at various duty cycles enables and disables the CCFL inverter or WLED driver's so that the average current through either the lamp or WLED string is the duty cycle times the maximum current. The maximum dimming ratio is limited by the time it takes the inverter or converter to startup, recharge the output capacitor and settle to their respective maximum currents. Even though simple WLED drivers configured as shown in Figure 4 operate at 1MHz + switching frequencies, compared to CCFL inverters running around 50kHz, both have control loop response times and/or startup times in the hundreds of microseconds to a few milliseconds range. Therefore, to allow time for the driver or inverter to settle at

its maximum current, the PWM dimming frequency can be only a few hundred Hertz. In practice, CCFL backlights achieve close to 10:1 dimming ratio under PWM dimming while higher performance WLED drivers, like the one shown in Figure 4, achieve closer to 100:1.

Figure 6 shows the block diagram of more recent WLED drivers which have replaced R_{SENSE} with an integrated, variable current regulator.

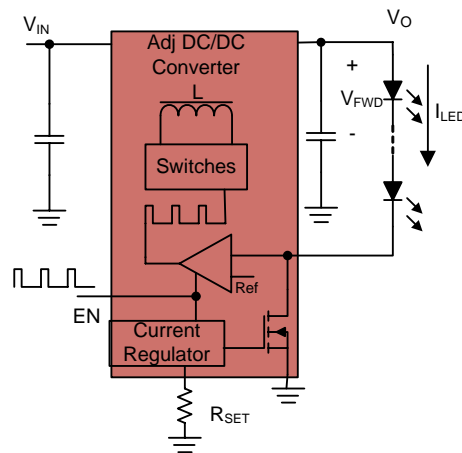
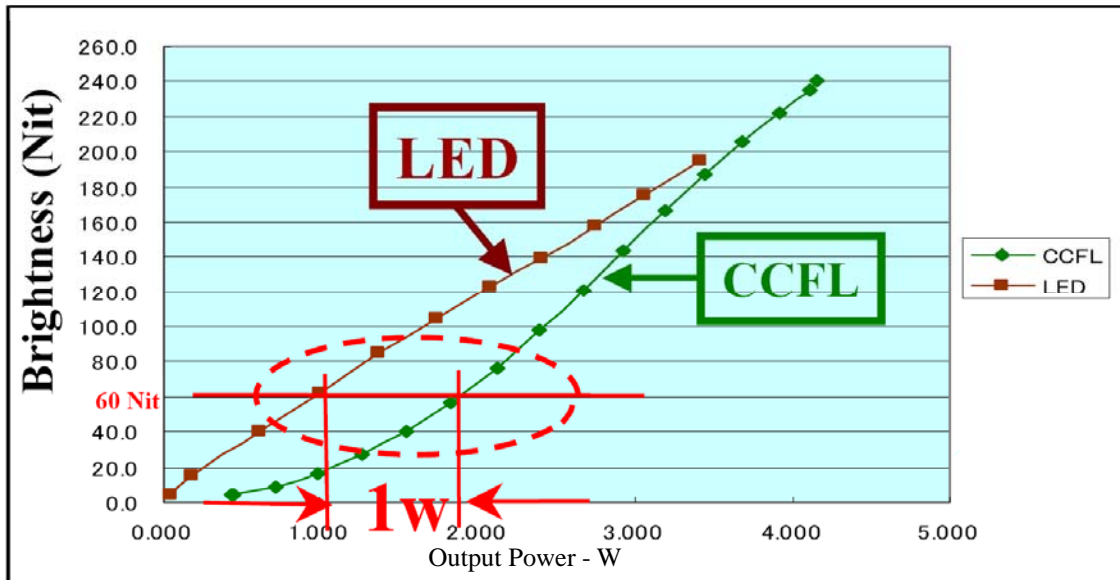

Figure 6 – Adjustable output converter with current sink to drive a WLED string

The current regulator's response time is much faster than the converter itself, in the hundreds of ns range. So, by controlling both the converter's switches and the current sink with the PWM dimming signal and keeping the output capacitor charged, the driver does not have to go through soft start to recharge the output capacitor and can achieve 1000:1 and larger dimming ratios at much higher PWM frequencies.

The final argument for LED instead of CCFL backlights relates to each backlight's energy consumption at the most common brightness level. Figure 7 shows a comparison of power required for LCD panel brightness, measured in NITs.



- Source: Toshiba Matsushita Display

Figure 7 – Comparing Power vs. Brightness for LED and CCFL backlight LCD Panel

A NIT is a measurement of light in candelas per meter square (Cd/m²). For an LCD monitor, a NIT is the brightness out of the front panel of the display. For optimal viewing, most desktop LCD's or Notebook LCD's require a brightness of 60-200 Nits depending on available office lighting, 500-900 Nits in indirect sunlight and at least 1000 in direct sunlight. Since a majority of notebooks and other MFF applications are indoors, WLED backlit panels require less power than CCFL backlit panels for the same brightness, meaning WLED backlit panels are more efficient than CCFL backlit at the most common, lower brightness levels. Given that the trend for almost all battery powered devices is smaller size and longer battery run time, it is easy to see why the smaller, simpler and more efficient WLEDs are overtaking CCFL for LCD backlighting.

Schematic comparison: Topology level

Now that a WLED current regulating driver has been selected for the backlight, the panel maker must choose the backlight's power topology, i.e. whether to use a buck converter or a boost converter. WLEDs have V_{LED} ranging from 3.0V to 4.0V with the drop varying directly with the LED current and inversely with temperature. Therefore, the WLED driver's output voltage must be capable of reaching at least the sum of the WLED V_{LED} drops at the maximum LED current in the string. Although the input voltage for the majority of backlight applications ranges from 3.6V to 48 V dc, most MFF LCD backlight drivers use 7.2V to 21V stacked Li-Ion cells to drive 24 to 100 LEDs. Table 1 shows the typical number of WLEDs for various MFF panel

sizes.

Table 1 – Number of WLEDs for MFF Panel Size

Panel Size	Quantity of WLED
12.1"	36
13.3"	42
14.1"	48
15.4"	60
17"	72

Even if the LEDs are distributed into a manageable number of parallel strings (e.g., 6) and a 21-V LiIon input supply is available, the backlight driver's output could be as high as 24V (i.e. 36 WLEDs / 6 strings * 4.0V) at cold temperatures. Therefore, most designers choose a dc/dc boost converter configured to regulate a constant current as backlight driver for MFF panels.

The WLEDs may be arranged in series or parallel. As long as the current through all of the LEDs is uniform, either configuration provides uniform lighting. Driver IC manufacturers require additional design time and die area when integrating multiple current regulators like the one shown in figure 6. Arranging the WLEDs in parallel configuration with current regulators has several advantages over the series configuration shown in Figure 4. As an example, Figure 8 shows a high voltage boost converter, configured to regulate current, for the 48 series WLEDs used to the backlight a 14.1 inch LCD panel. Given that a typical WLED has around 3.0V to 3.5V forward voltage drop, the boost converter needs to provide at least 168 V output voltage (V_o).

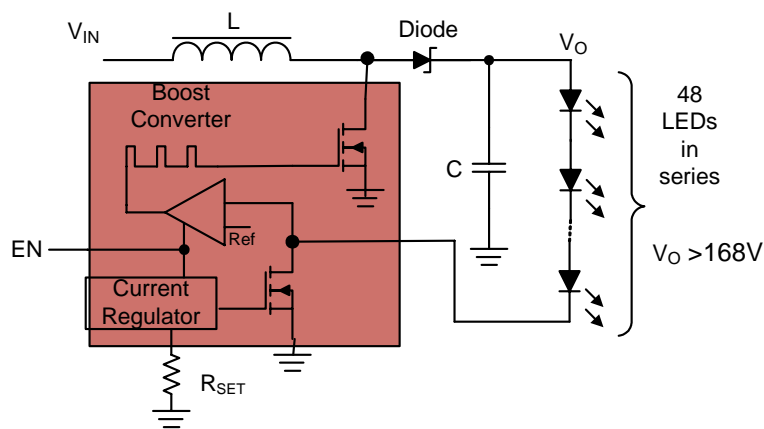

Figure 8 – Boost converter based backlight driver with 48 LEDs in series

High voltage, single inductor boost converters are expensive and difficult to design because they

- Require higher voltage rated, and therefore larger and more expensive, power FET (168-V rated in the example above), similarly rated diode and output capacitors,

- Require a boost controller capable of duty cycles ($D=V_{out}/(V_{out}+V_{in})$) from 87.5-96%, which, assuming 1MHz switching frequency, results in on-times (t_{ON}) of 875-960ns and very difficult to control minimum off time (t_{OFF}) of 40ns.
- Require a costly and space consuming insulation barrier to prevent arcing to chassis,
- Require high-voltage handling and testing procedures,
- Require additional consumer product safety ratings, and
- Produce more EMI due to higher common mode current, computed as $I_{CM} = C_{PAR} * V_{OUT} * f_{SW}$, where C_{PAR} is the parasitic board capacitance from drain to earth ground and f_{SW} is the boost converter switching frequency.

In addition, if one LED in the series fails with open circuit, the boost converter control loop opens, potentially destroying the boost converter with no over-voltage protection circuitry and killing the entire backlight, causing the display to go dark. Moving to a fly-back topology instead of an inductor based boost topology allows the use a standard, lower cost boost controller IC and with the expense of a custom designed transformer. But, when using a single LED string to drive MFF sized backlights, it is clear that the panel maker continues to have costs and design challenges associated with high voltage design, similar to those seen by panel makers using CCFL based backlights

The ideal WLED driver meets the panel brightness requirements across all ambient lighting conditions and uses a standard boost converter core that is modified to regulate current as demanded by internal current sinks. In addition, this modified boost converter must be operational with low-cost active and passive components such as ceramic input and output capacitors. Figure 9 shows a block diagram of this boost-converter-based backlight driver configured with m parallel strings of n series LEDs. All of the LEDs have the same current running through them to ensure uniform brightness.

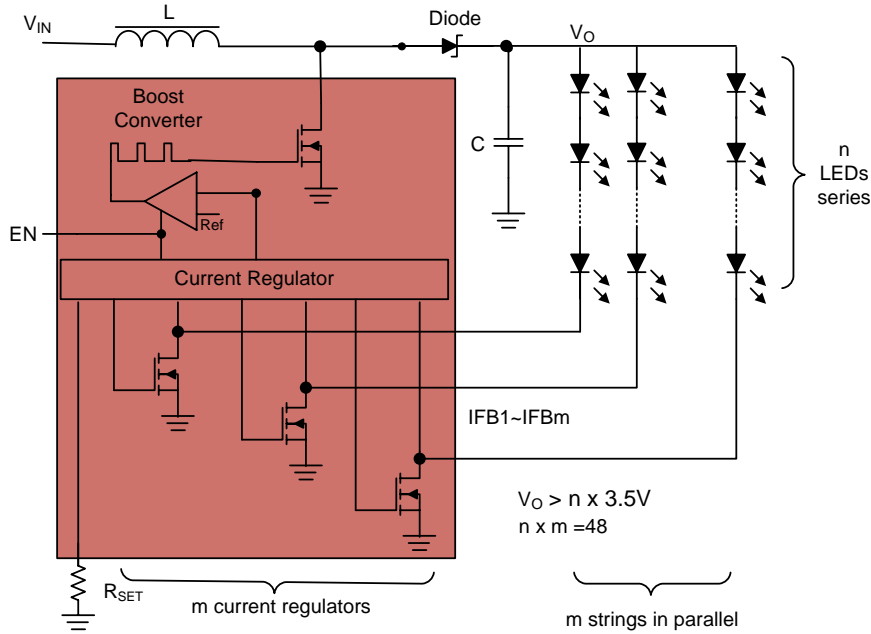

Figure 9 – Boost converter based backlight driver with parallel LED strings

The next question becomes how to select n and m . There are several major factors to consider:

- n determines the output voltage level of boost converter. Higher output voltages require higher voltage-rated, and therefore more expensive driver ICs as well as the external supporting active and passive components. If the boost-based driver IC has an integrated FET, the IC manufacturer prefers to keep the maximum rated voltage low, typically below 50-60V given today's technology, to minimize die size and therefore cost. While incremental voltage rating steps, and related price increases, for FETs and diodes are small, the price of a 50-V rated diode compared to a 100-V rated diode cannot be ignored. The increase in price and physical size between a 50-V rated ceramic capacitor and a 100-V rated ceramic capacitor is significant. So, keeping $n_{\max} \times V_{LED\max} < 50V$ minimizes a driver solution's total component cost.
- A minimum number of WLEDs is connected in series to keep $V_{OUT} > V_{IN}$ so $n_{\min} \times V_{LED\min} > 21V$ from the stacked LiIon cells
- m determines the brightness requirement and sets the converter's maximum load current, $I_{LOAD\max} = m \times I_{LED\max}$.

For example, if $V_{LED\max}=3.0V$ and $I_{LED\max} = 20mA$, then $n_{MIN}=7$. If the total number of WLEDs is 48, then $n=8$ and $m=6$ is one of the possible combinations. Therefore, the output voltage should be higher than $3.0 V \times 8 = 24 V$ with a total of $20mA \times 6=120mA$

load current. In order to further optimize the values for n and m , the backlight driver's efficiency is analyzed in the following section.

Efficiency Analysis

Equation 1 shows the backlight driver system's overall efficiency.

$$Efficiency = \frac{P_{OUT}}{P_{OUT} + P_{Loss}} \quad (1)$$

where

$$P_{OUT} = I_{Load} \times V_{OUT} = m \times I_{LED} \times n \times V_{LED} = l \times I_{LED} \times V_{LED} \quad (2)$$

where l is the total number of LEDs. (2)

and

$$I_{Load} = \frac{P_{OUT}}{V_{OUT}} \quad (3)$$

The backlight driver is essentially a boost converter and a current regulator, each contributing losses to the overall system.

$$P_{Loss} = P_{Loss_boost} + P_{Loss_curr_reg} \quad (4)$$

A boost converter's primary loss contributors are the NMOS power switch, including switching losses, the free-wheeling diode and the inductor.

$$P_{Loss_boost} = P_{Loss_switch} + P_{Loss_diode} + P_{Loss_inductor} \quad (5)$$

The power switch has both conduction losses and switching losses.

$$P_{Loss_switch} = P_{Loss_nmos} + P_{Loss_sw} + P_{Loss_cbs} \quad (6)$$

with P_{LOSS_NMOS} being the conduction losses, P_{LOSS_SW} being one component of the switching loss and P_{LOSS_CDS} being the other switching loss component Equation 7 calculates the NMOS FET's conduction losses.

$$\begin{aligned}
P_{Loss_nmos} &= \frac{V_{OUT} \times I_{Load}^2 \times (V_{OUT} - V_{IN}) \times R_{dson}}{V_{IN}^2} \quad (7) \\
&= \frac{P_{OUT}^2 \times \left(1 - \frac{V_{IN}}{V_{OUT}}\right) \times R_{dson}}{V_{IN}^2} \\
&= \frac{P_{OUT}^2 \times \left(1 - \frac{V_{IN}}{\frac{l}{m} \times V_{LED}}\right) \times R_{dson}}{V_{IN}^2}
\end{aligned}$$

where R_{DSON} is the NMOS FET's drain to source resistance.

The power required to turn the FET on and off is a significant component of the switching loss as computed in Equation 8.

$$\begin{aligned}
P_{Loss_sw} &= \frac{I_{Load} \times V_{OUT}^2 \times (Tr + Tf)}{V_{IN}} \\
&= \frac{P_{OUT} \times V_{OUT} \times (Tr + Tf)}{V_{IN}} \\
&= \frac{P_{OUT} \times \left[\left(\frac{l}{m}\right) \times V_{LED}\right] \times (Tr + Tf)}{V_{IN}} \quad (8)
\end{aligned}$$

where Tr and Tf are the rise time and fall time of the FET drain to source voltage, indicating the FET turn-off and turn-on speeds respectively.

The energy stored in the FET's drain to source (output) capacitor is completely dissipated in every switching cycle and is also a switching loss as computed in Equation 9.

$$\begin{aligned}
P_{Loss_cds} &= C_{DS} \times V_{OUT}^2 \times f_{sw} \\
&= C_{DS} \times \left(\frac{l}{m}\right)^2 \times V_{LED}^2 \times f_{SW}
\end{aligned} \tag{9}$$

where Cds is the MOSFET output capacitance and fs is the switching frequency.

Equation 10 shows how to compute the diode's conduction loss.

$$\begin{aligned}
P_{Loss_diode} &= I_{Load} \times V_{DIODE} \\
&= \frac{P_{OUT}}{V_{OUT}} \times V_{DIODE} \\
&= m \times I_{LED} \times V_{DIODE}
\end{aligned} \tag{10}$$

The inductor power loss includes copper conduction loss and core loss. Equation 10 shows how to compute the inductor's copper loss.

$$\begin{aligned}
P_{Loss_inductor} &= \frac{I_{Load}^2 \times V_{OUT}^2 \times R_{inductor_dcr}}{V_{IN}^2} \tag{11} \\
&= \frac{P_{OUT}^2 \times R_{inductor_dcr}}{V_{IN}^2} \tag{12}
\end{aligned}$$

The computation of the inductor core loss is beyond the scope of this article but is negligible for converter's running near 1MHz switching frequency and using the most recent inductors. Note that for the boost converter every loss term increases as V_{OUT} increases, some as the square of V_{OUT} and V_{OUT} increase as the number n series LEDs.

$$P_{loss_curr_reg} = I_{LED} \times \sum_{x=1}^m V_{IFBx} \tag{12}$$

The losses in the current regulator are simply each string's current times the voltage at each current feedback pin, IFB_x, as illustrated in Figure 8. For optimal efficiency, the driver must sense the voltage drop at each V_{IFBx} pin and use the boost converter to provide just enough output power to keep the lowest V_{IFBx} pin voltage (V_{IFBmin}) above its current regulator's maximum dropout voltage. This, in turns, results in the output voltage rising to the sum of the V_{LEDs} of the string having the WLEDs with the largest

V_{LEDs} plus V_{IFBmin} . Because the voltages at the remaining V_{IFB} 's are higher due to the LEDs in the remaining strings having lower voltage drops, the remaining current regulators waste power. Statistically, there is an optimal number of m strings n LEDs per string to minimize that power loss and maximize the driver's efficiency.

For a large population of LEDs, an individual LED forward voltage approximates an average distribution as illustrated in Figure 10 below.

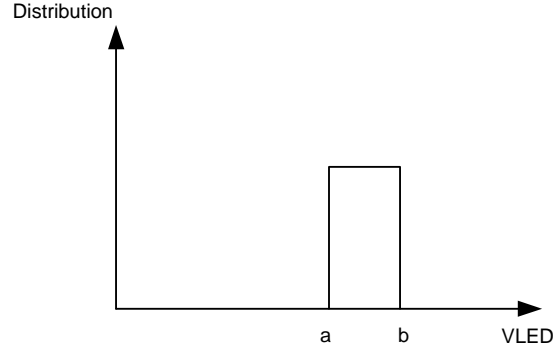

Figure 10 – LED voltage average variation.

Equation 13 gives expected value of such a distribution

$$E(V_{LED}) = \frac{a+b}{2} \quad (13)$$

with a variance of

$$D(V_{LED}) = \frac{(b-a)^2}{12} \quad (14)$$

With n LEDs in series, the average forward voltage of n LEDs follows the normal distribution as shown in equation 15.

$$D(\overline{V_{n \times LED}}) = \frac{1}{n^2} \sum_{x=1}^n D(V_{LEDx}) = \frac{1}{n} D(V_{LED}) \quad (15)$$

with variance

$$\sigma = \sqrt{D(\overline{V_{n \times LED}})} = \frac{1}{\sqrt{n}} \sqrt{D(V_{LED})} \quad (16)$$

Since the n LEDs are in series, the total variance of n LEDs is

$$n\sigma = n\sqrt{D(\overline{V_{n \times LED}})} = \sqrt{n} \sqrt{D(V_{LED})} \quad (17)$$

Thus the power loss in the current regulator becomes a function of the m strings, n LEDs per string and the distribution values.

$$\begin{aligned}
 P_{loss_curr_reg} &= I_{LED} \times m \times (VIFB_{bias} + n\sigma) \\
 &= I_{LED} \times [m \times VIFB_{bias} + m \times \sqrt{n} \times \sqrt{D(V_{LED})}] \quad (18)
 \end{aligned}$$

So, $P_{LOSS_CURR_REG}$ increases as the number of m strings but only as the square root of the number of n series LEDs; in other words, fewer m strings minimizes losses in the current regulator..

Using the previously derived equations and following assumptions, Figures 12 through 14 show losses and total efficiency under the same conditions and the same driver but with two different configurations: a $m=6$ and $n=12$ (i.e., 12S6P) set of strings and a 9S8P set of strings.

- WLED forward voltage distribution: 3.0V to 3.5V
- WLED forward current: 20mA
- Boost Converter Switching Frequency: 1MHz
- T_r+T_f : 4.5ns
- $R_{inductor_esr}$: 200mOhms
- R_{dson} : 200mohms
- C_{ds} : 100pf
- Inductor: 10uH
- Rectified Diode: $V_{diode}=0.5V$
- $V_{in}=11V$
- $VIFB_{bias}=0.4V$

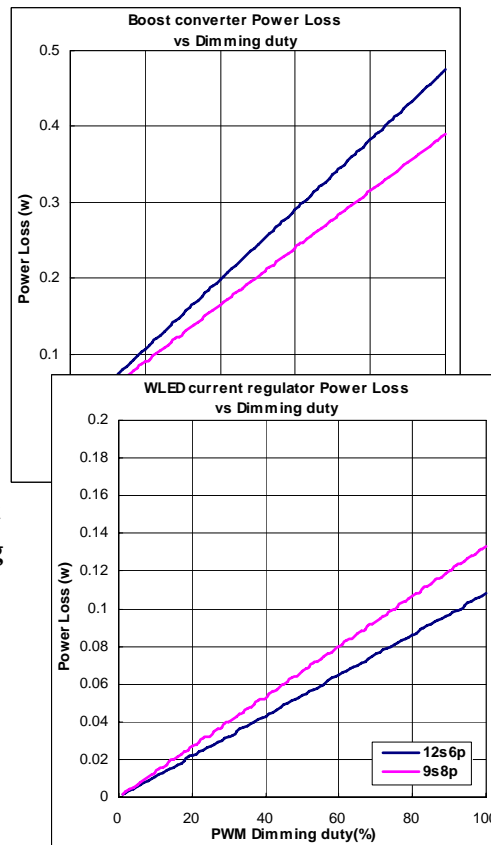

Figure 11 – Boost Loss vs. Dimming comparison

Converter Power Duty Cycle

Figure 12 – Current Regulator Power Loss vs. Efficiency comparison

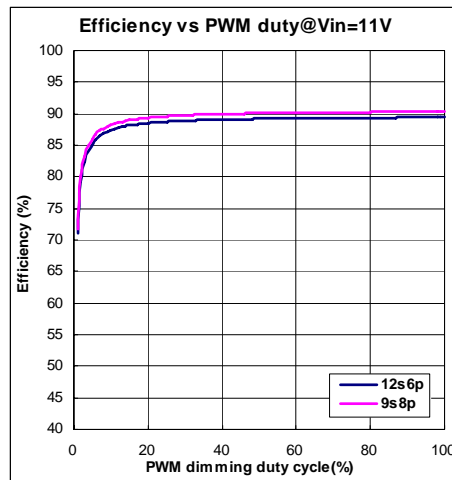

Figure 13 – Total efficiency comparison

Figure 14 uses the same equations and assumptions to provide guidance on choosing the n and m combination that minimizes losses and therefore provides the highest efficiency backlight driver.

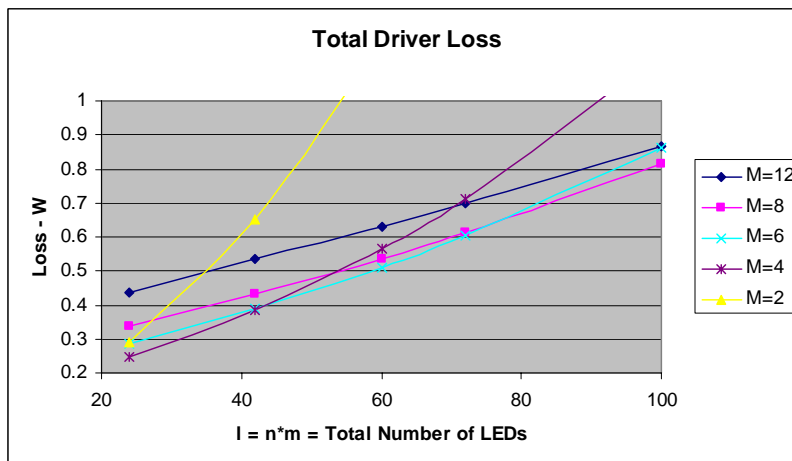

Figure 14 – Total number of LEDs vs. Total Driver Losses

Analog vs. PWM dimming LEDs

The simplest method of dimming a WLED string is to apply a PWM signal at a fixed frequency with duty cycle of D to the driver in figure 4 enable pin so that the boost converter itself is switched on and off at that duty cycle. The average WLED current is the duty cycle times the LED current I_{LED} . Using this method, the maximum PWM signal frequency for driver as shown in figure 4 is typically limited to 1kHz or so by the converter's startup time. However, ceramic output capacitors can cause a problem when PWM dimming is used. Figure 15 illustrates how the dielectric of ceramic capacitors suffers from converse piezoelectric effect meaning that the package undergoes stress and/or strain when an electric field is applied.

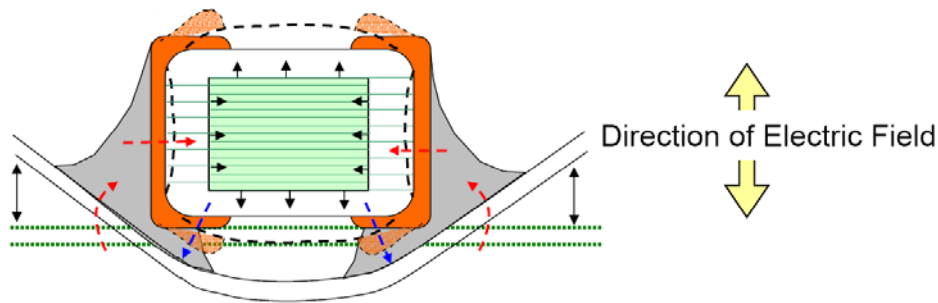

Figure 15 – Ceramic capacitor piezoelectric effect

The dielectric expands in the direction of electric field, and contracts in the direction of a plane vertical to the direction of the electric field as it discharges. Moreover, the surface mounted multi-layer ceramic capacitor (MLCC) is pulled to the center and bends in the vertical direction of the substrate's plane surface. Being mounted on an incline, the capacitor's external electrode also bends in the vertical direction of substrate's plane surface. When the capacitor has no bias (i.e. is discharged), the substrate returns to the initial position. So, if the capacitor is charged and discharged at a frequency in the audible range (20Hz-20kHz), the human ear will hear the substrate motion as a ringing or buzzing.

The vibration of the substrate is directly proportional to voltage amplitude and ceramic capacitor package size. Reducing capacitor package size, for example by replacing one 805 packaged 4.7uF capacitor with two 2.2 uF, 0603 packaged capacitors, reduces the ringing. Measurements confirm that when the output ripple is below 200mV, the vibration is inaudible to all but the most sensitive of human ears. By replacing the current sense resistor in figure 4 with the current regulator of figure 6, PWM dimming can be used to temporarily disable both the boost converter and current regulator. With the current regulator disabled, the output capacitor does not discharge completely and the output ripple is minimized. Analog dimming causes virtually no output ripple because an external dc voltage adjusts the boost converter's regulation

point and therefore the current through the LEDs.

The impact that PWM dimming and analog dimming have on LED brightness and driver efficiency determine the circumstances during which one or the other should be used. To understand each method's effect on overall driver efficiency, figure 16 shows how a NSSW100CT WLED's forward voltage varies significantly over current.

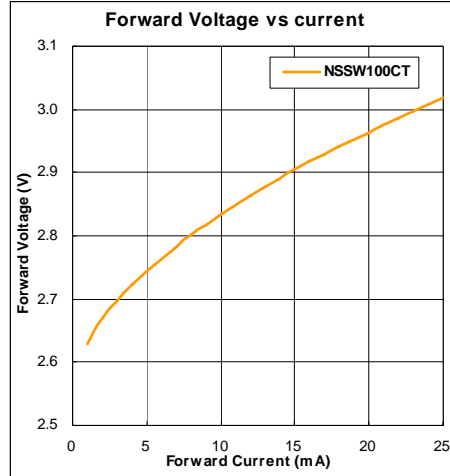

Figure 16 – NSSW100CT WLED Forward Voltage Characteristic

With analog dimming, each LED's forward voltage varies directly with dimming duty cycle while, with PWM dimming, each LED's V_{LED} stays the same, as shown in Figure 17.

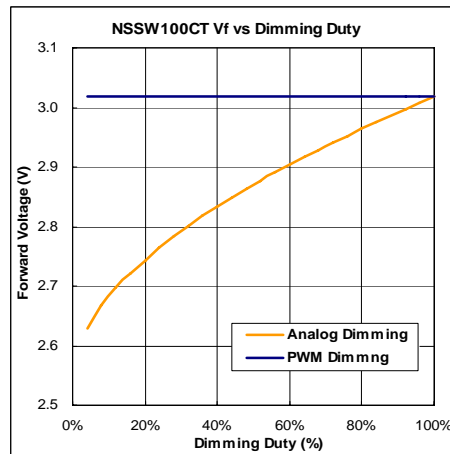

Figure 17 – Forward Voltage vs. Dimming Duty Cycle

One can calculate the power dissipation of a single WLED using the equation below:

$$\text{PWM Dimming Mode: } P_{WLED} = V_{LED@ILED_MAX} \times I_{LED(max)} \times D_{PWM}$$

$$\text{Analog Dimming Mode: } P_{WLED} = V_{LED@ILED_ACT} \times I_{LED(ACT)}$$

Specifically, analog dimming provides around 5mW power saving for one WLED compared to the same LED dimmed at 50% duty cycle using PWM dimming. Extrapolating this to 14.1” panel with 48 WLEDs, 5mWx48=240mW of power is potentially saved by using analog dimming. Figures 18 through 22 show measured data from a backlight with $n=10$ NSSW100CT series WLEDs and $I_{LED(max)} = 25mA$ at room temperature. Figure 18 shows how the driver’s output voltage changes when using analog dimming and PWM dimming.

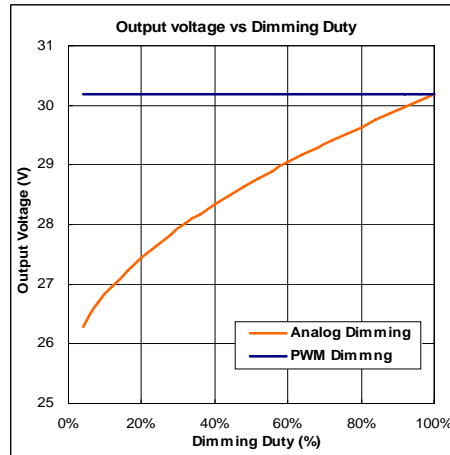

Figure 18 – Backlight driver Output Voltage ($n \cdot V_{LED}$) vs. Dimming Duty Cycle

The measured data in figure 19 confirms equations 4 through 11 predictions that higher output voltage reached during PWM dimming results in higher converter losses compared to analog dimming. In other words, the driver’s boost converter is more electrically efficient when analog dimming than when PWM dimming for the same average LED current and input voltage.

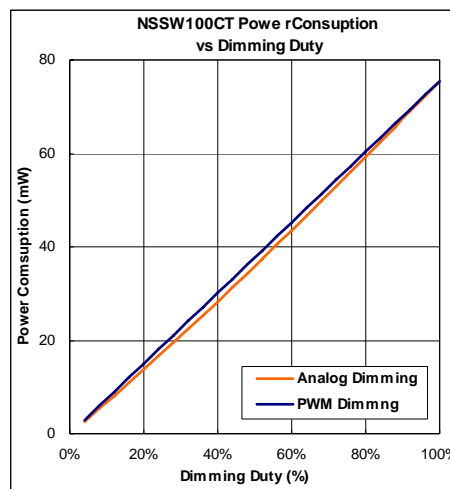

Figure 19 –Power Consumption vs. Dimming Duty Cycle

Electrical to optical efficiency relates LED brightness, measured in the lumens, to

power consumed. Using the same WLED under the previously illustrated power consumption conditions Figure 20 shows the measured LED brightness when the WLEDs are dimmed by analog dimming and PWM dimming.

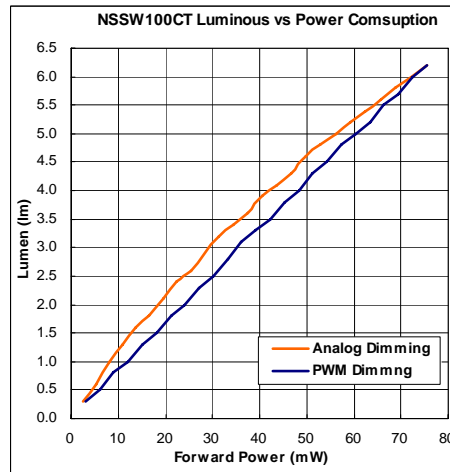

Figure 20 – Lumens vs. Power Consumption

Figure 20 shows that analog dimming provides more optical power output while consuming less electrical power than PWM dimming over the entire dimming duty range, i.e., analog dimming has higher electrical to optical efficiency. Changing the x axis from figure 20 to dimming duty cycle, directly related to LED current, Figure 21 shows how the LED current itself relates to brightness under the two dimming methods.

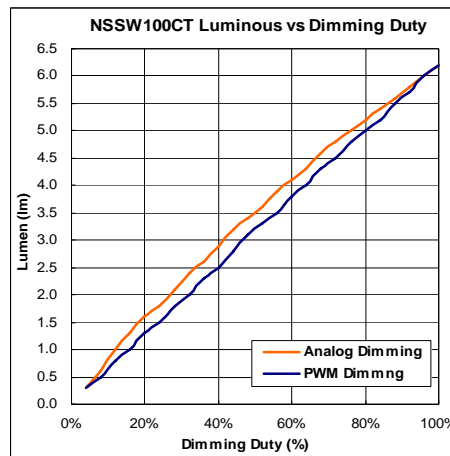

Figure 21 – Lumens vs. Dimming Duty

The WLED's brightness linearity with analog dimming is not as good as the linearity achieved with PWM dimming. So, PWM dimming provides better linear optical power output when compared to analog dimming.

Chromaticity is an objective specification of the quality of a color irrespective of

its luminance, that is, as determined by its colorfulness (or saturation, chroma, intensity, or excitation purity) and hue. For a WLED, this is a measure of how “white” it really is. Since a WLED’s chromaticity varies slightly with V_{LED} , the variation of V_{FWD} with current shown in figure 16 predicts a slight variation in chromaticity when performing analog dimming. When PWM dimming, V_{LED} is constant, there is essentially no chromaticity variation. The measured chromaticity data for an NSSW100CT in Figure 22 confirms that chromaticity shift when analog dimming versus PWM dimming. The blue loop in Figure 22 is a result of poor measurement tolerance. This variation in a backlight’s “whiteness” is only noticeable to the human eye when comparing two monitors side by side.

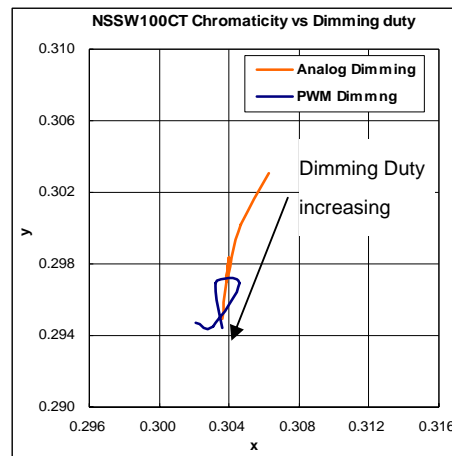

Figure 22– Chromaticity vs. Dimming Duty

Based on the preceding analysis, PWM dimming is superior in providing good linearity and no variation in chromaticity over a wide range of average LED current. Analog dimming is more electrically efficient and does not cause audible noise in the output capacitors. But, analog dimming has some current accuracy problems for deep dimming because either the V_{REF} voltage or the current sink voltage becomes too small to accurately control due to the offset voltage of the error amplifier. So, the optimal solution is to combine the PWM and analog dimming methods, termed mixed mode dimming, as illustrated in Figure 23.

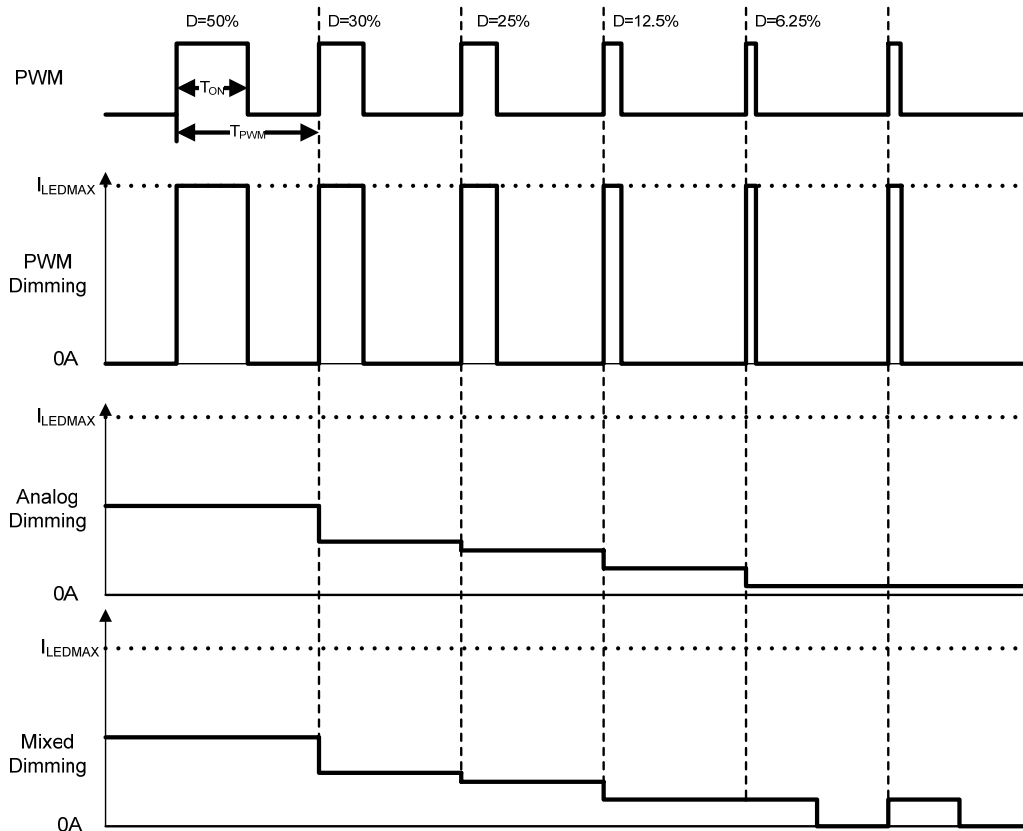

Figure 23 – Mixed mode dimming

Mixed mode dimming uses the input PWM signal to implement analog dimming until just before the LED current drops low enough to affect LED accuracy, linearity and chromaticity. In figure 23, that current is reached when the PWM signal duty cycle (D) is 12.5%. At this minimum current level, the circuit begins using true PWM dimming. However, instead of turning on and off the maximum LED current through the current sinks at the input PWM signal's duty cycle, the circuit translates the input duty cycle to the appropriate value for the minimum WLED current level achieved with analog dimming.

Based on the preceding analysis, Texas Instruments developed the TPS61195 WLED driver as shown in figure 24.

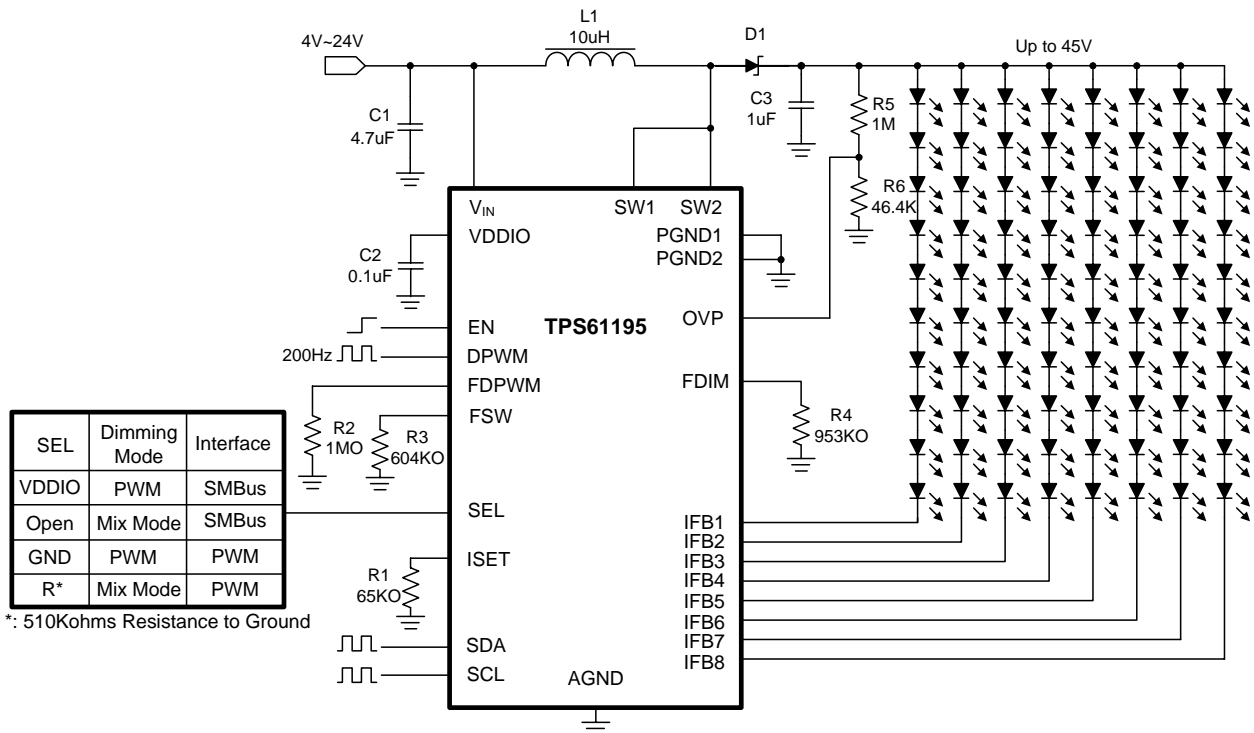

Figure 24 – TPS61195 backlight driver

The TPS61195 is capable of driving up to $m = 8$ strings (in parallel) each with $n = 10+$ WLEDs (in series). Through the SMBus interface, the TPS61195 also provides flexible dimming options so that the design engineer can dim the WLEDs using either pure PWM dimming or a mixed mode of analog and PWM dimming, according to the system requirement. Figure 25 shows the efficiency achieved under the different dimming methods configuration with the TPS61195 configured as shown in Figure 24 with $V_{IN} = 12\text{ V}$ and 10S8P.

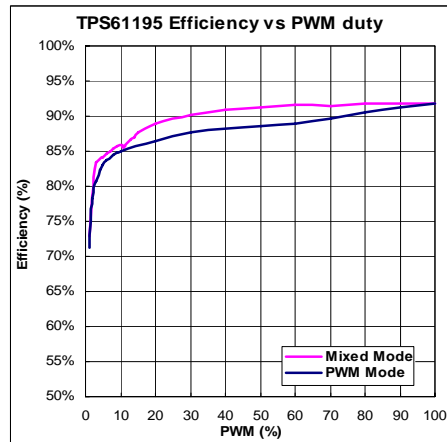

Figure 25 – TPS61195 Efficiency vs. PWM dimming duty

For applications requiring the most consistent and predictable changes in WLED brightness and hue, the TPS61195 in PWM dimming mode provides linear changes in output current with dimming duty cycle as shown in Figure 26.

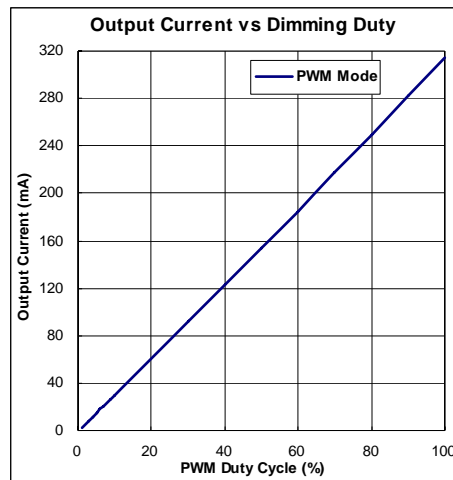

Figure 26 - PWM dimming mode dimming accuracy and linearity.

But, like all drivers using PWM dimming, the TPS61195 has output voltage ripple, as shown in figure 27, that can cause audible noise in ceramic output capacitors.

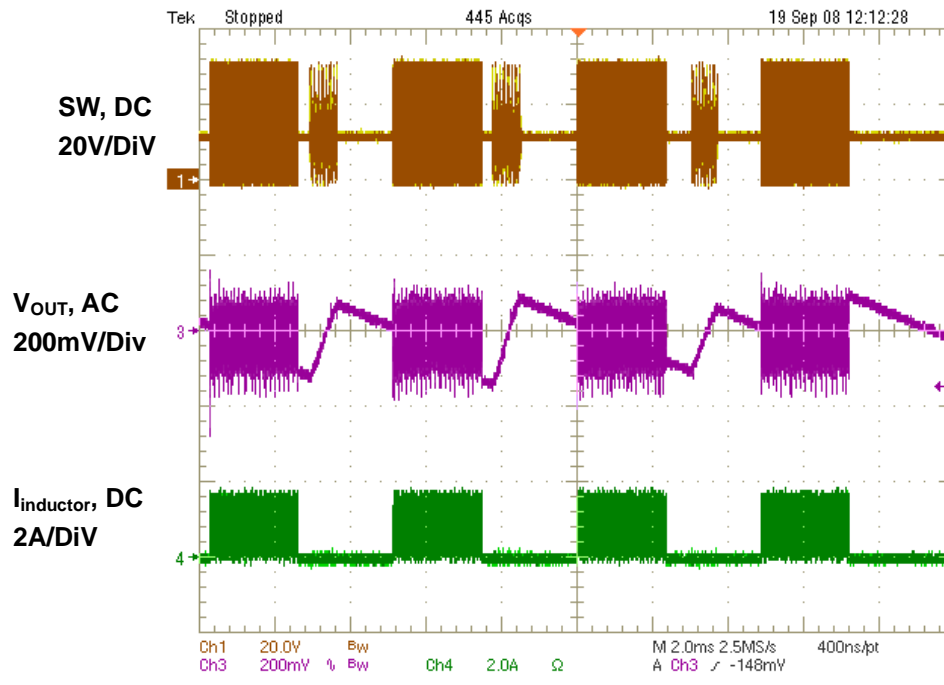

Figure 27 - Output ripple of TPS61195 PWM dimming mode.

If the audible noise cannot be reduced by changing the output capacitor type or using multiple smaller packaged capacitors, then mixed mode dimming is the best option. Being a mixture of pure PWM and pure analog dimming, mixed mode dimming combines the best characteristics of analog dimming and PWM dimming. Figure 25 shows the efficiency improvement when using mixed mode dimming instead of PWM dimming. Figure 28 shows the TPS61195's dimming linearity and accuracy over the entire output current range which virtually eliminates the non-linear brightness changes and color shift with current normally associated with pure analog dimming.

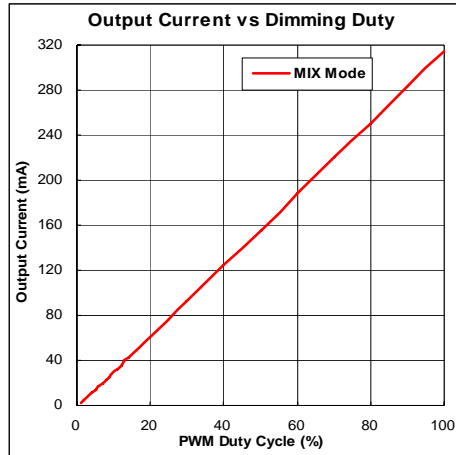
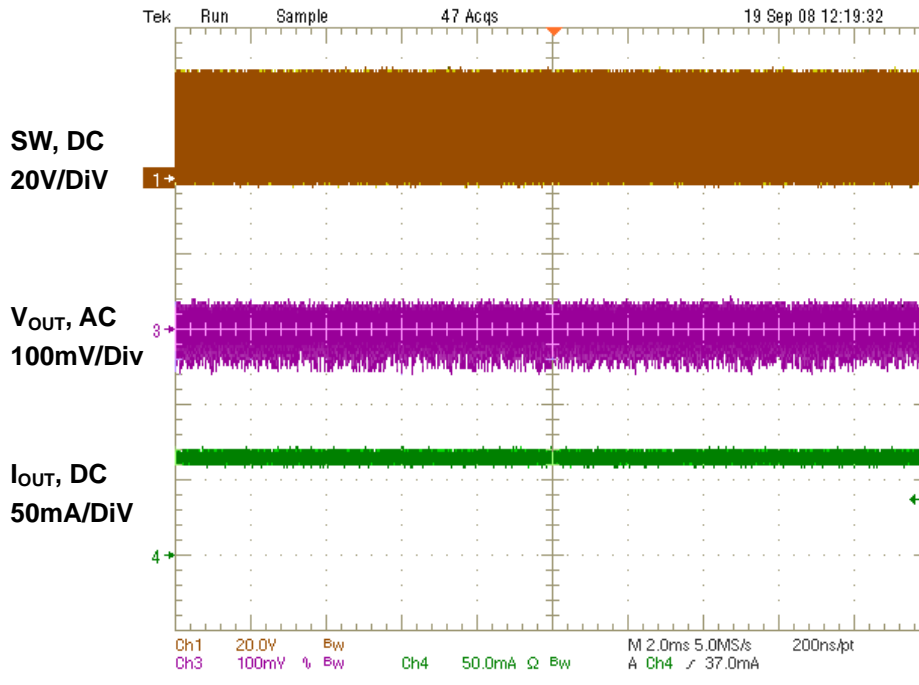
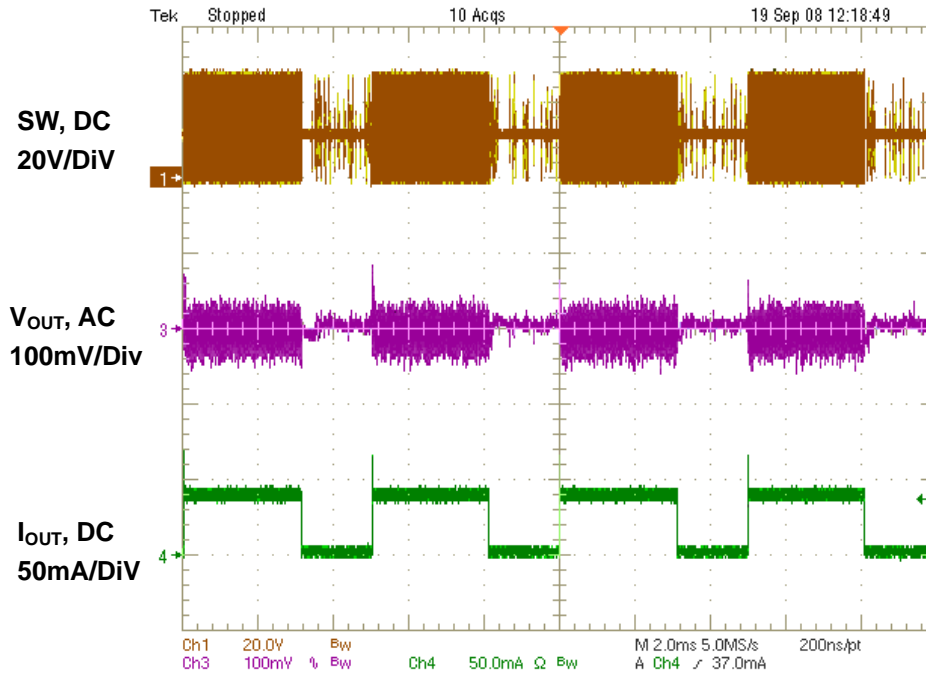

Figure 28 - Mixed mode dimming accuracy and linearity.

Figures 29 and 30 show the reduced output voltage ripple in mixed mode dimming, which results in significantly reduced audible noise.



**Figure 29 - Output ripple of TPS61195 Mixed mode dimming mode.
 ----brightness = 20%**



**Figure 30 - Output ripple of TPS61195 Mixed mode dimming mode
-----brightness=8%**

Conclusion

Experts predict that WLED's will completely replace CCFL's in MFF LCD panel backlight by 2011. Backlight driver manufacturers are continually improving the backlight drivers in order to meet the panel makers need for small solution size, maximum efficiency and flexible dimming. TI's 4x4 QFN packaged TPS61195, driving 8 strings of 12 WLEDs each from input voltages up to 21 V and providing flexible dimming, meets these needs.