

## DCR01 Low Noise Power Supply 200mA@5 V

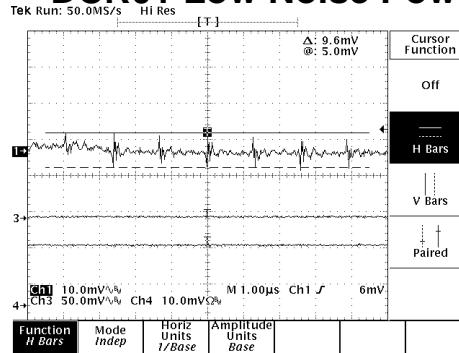

Typical noise and ripple at 100MHz band width after the filter components. CH#1 Close Coupled scope on second page.

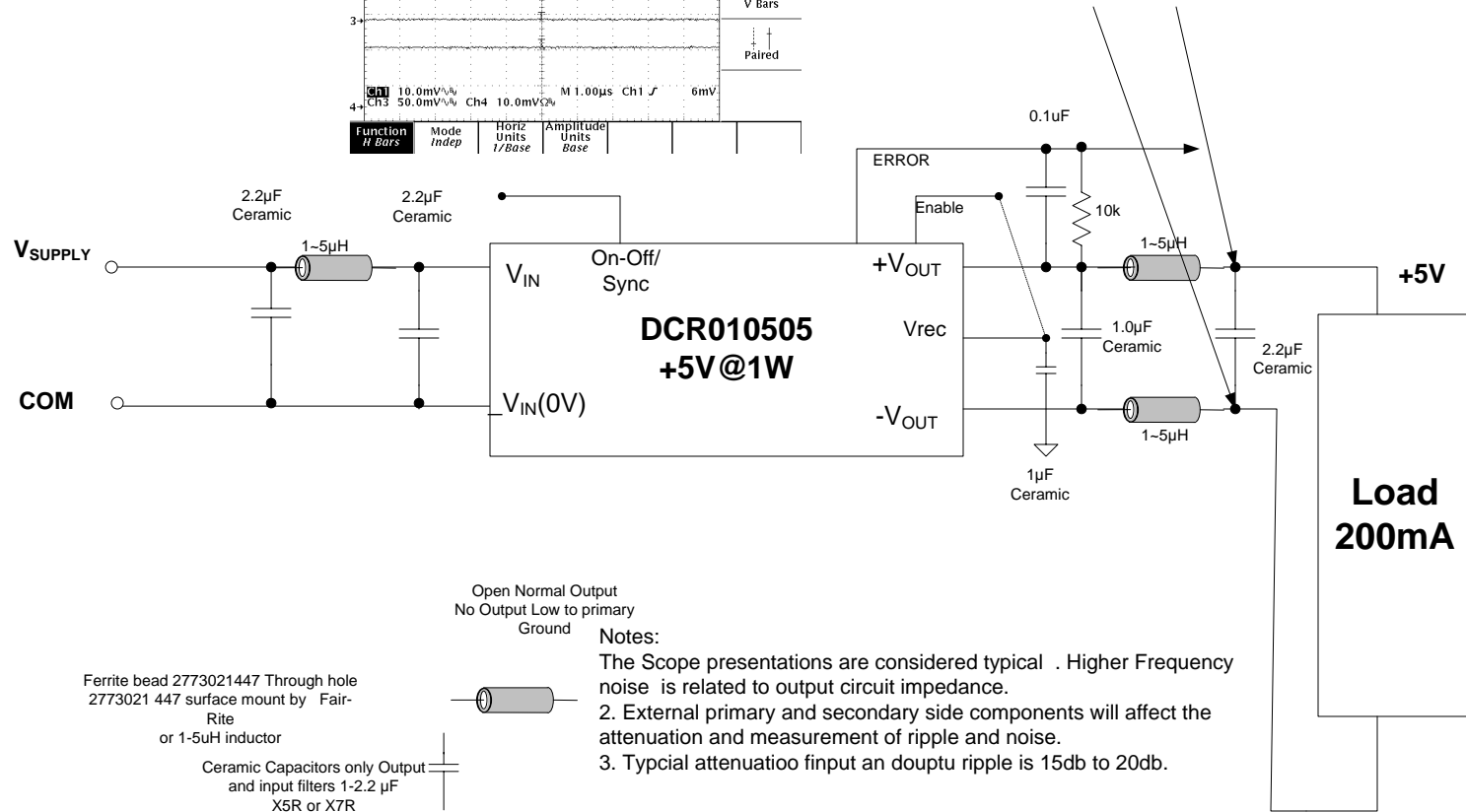

Note:  
Input Inductor recommended for attenuation input noise  
Output inductors and ceramic capacitors required for Analog  
low noise filter



## Scope High Frequency Measurement Method Page 2

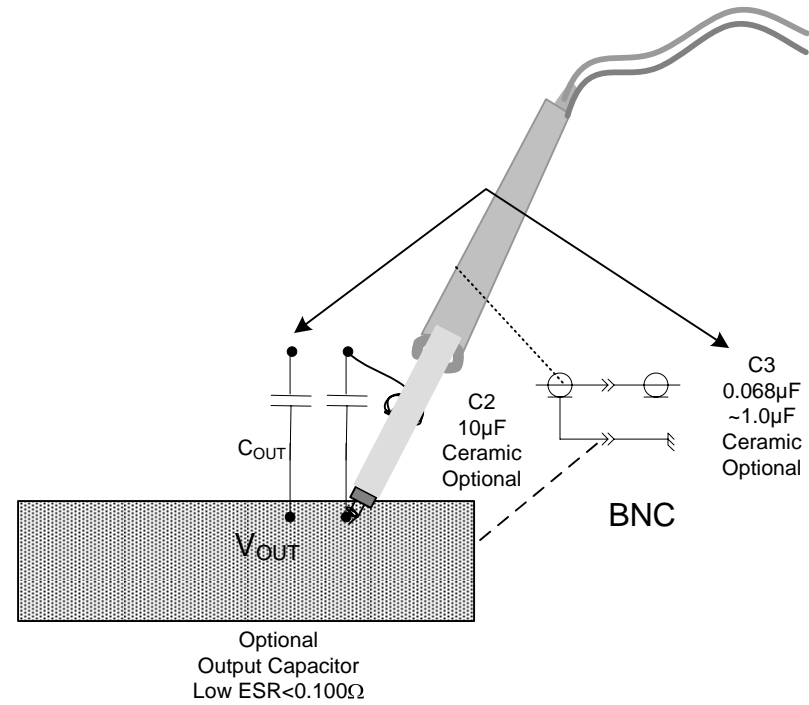
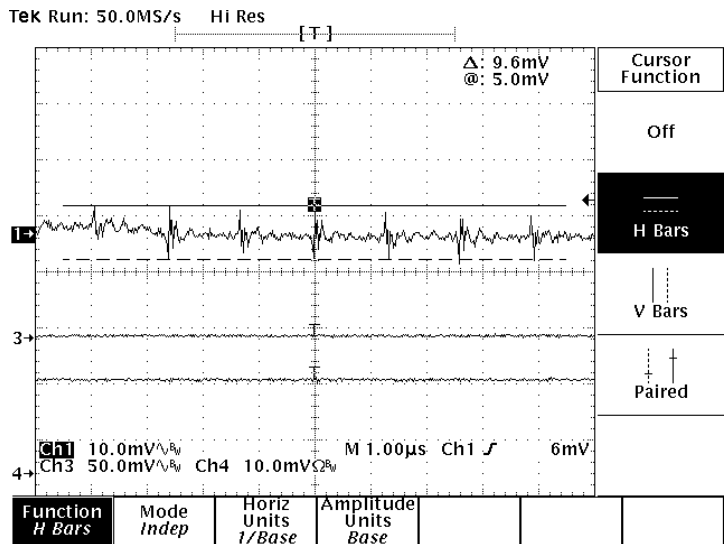
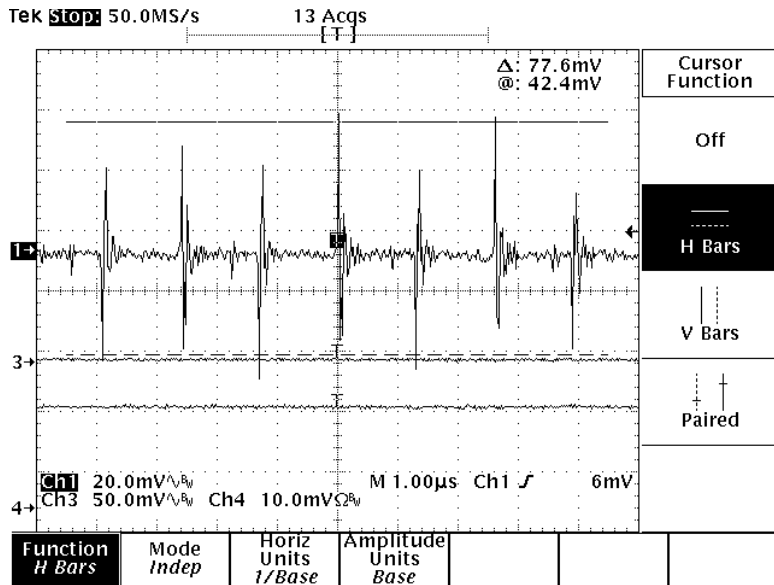

Notes:  
The Scope presentations are considered typical Noise Values.