

Power Management Guide



→ Table of Contents

Texas Instruments (TI) offers complete power solutions with a full line of high-performance products. These products, which range from standard linear regulators to highly efficient DC/DC converters and battery management, are tailored to meet your design challenges. And, TI makes designing easier by providing leading-edge support tools such as training, a broad selection of evaluation modules (EVMs), application notes, comprehensive technical documentation and more. TI also offers samples and small orders (shipped within 24 hours via TI authorized distributors) that will help you accelerate your time-to-market.

Included in this selection guide you will find design factors, featured products, graphic representations of portfolios and parametric tables. Also identified are devices qualified for HiRel and automotive applications. Some device options may not be available and pricing will be different.

For more information about HiRel and military versions of Power Management products, please visit:

www.ti.com/hirel

For more information about automotive-qualified Power Management products, please visit:

www.ti.com/automotive

my.TI Account Register Today!

Stay informed on:

- New product releases
- Design tools
- Samples
- Evaluation modules
- Guides
- System block diagrams

www.ti.com/myTI

It's easy and quick!

Portable and Line Power Solutions	
Line Power Solutions	3
Portable Power Solutions	3
Emerging Power Applications	
Overview	4
Power for Smart Meters	4
LED Lighting	5
Wireless Power (bqTESLA)	6
Energy Harvesting	6
Solar Charging	7
HEV Battery Management	8
High-PSRR Telecom	9
Point-of-Load Solutions	
Overview	10
Integrated Power Solutions (with Built-in Inductor)	11
Step-Down (Buck) Converters	13
Step-Up (Boost) Converters	16
Buck-Boost Converters	19
Linear and Low Dropout (LDO) Regulators	20
Multi-Output Power Management Units	24
DC/DC Controllers (External Switch)	27
Charge Pumps	30
Digital PWM Controllers and Drivers	32
Non-Isolated Power Modules	35
NexFET™ Power MOSFETs	38
Isolated Solutions	
Overview	41
Power Factor Correction (PFC)	42
PWM Power Supply Controllers	43
MOSFET Drivers	48
Digital PWM Controllers	50
Isolated Power Modules	51
LED Lighting	
LED Driver Controllers	52
LED Video Display Drivers	54
Display Power	
Overview	56
Display Bias, Level Shifters and Scan Drivers	56
LED Backlighting Drivers	59
Battery Management Products	
Overview	62
Charger Front-End Protection	63
Battery Charge Management	63
Single-Cell Solutions – Battery Fuel Gauges	67
Single-Cell Solutions – Authentication for Batteries and Peripherals	68
Multi-Cell Solutions – Battery Fuel Gauges	69
Multi-Cell Solutions – Lithium-Ion Protection	71
Power Protection and Control	
Overview	72
Power-over-Ethernet	72
Protection and Power Switches	74
Voltage Supervisors and Digital Sequencers	83
Special Applications	
White LED Backlight, High-Current LED and Camera LED Flashlight Drivers	86
Resources	
Design Support	88
Packaging	90
Device Index	92
TI Worldwide Technical Support	(back cover)

Portable and Line Power Solutions



Line Power Solutions

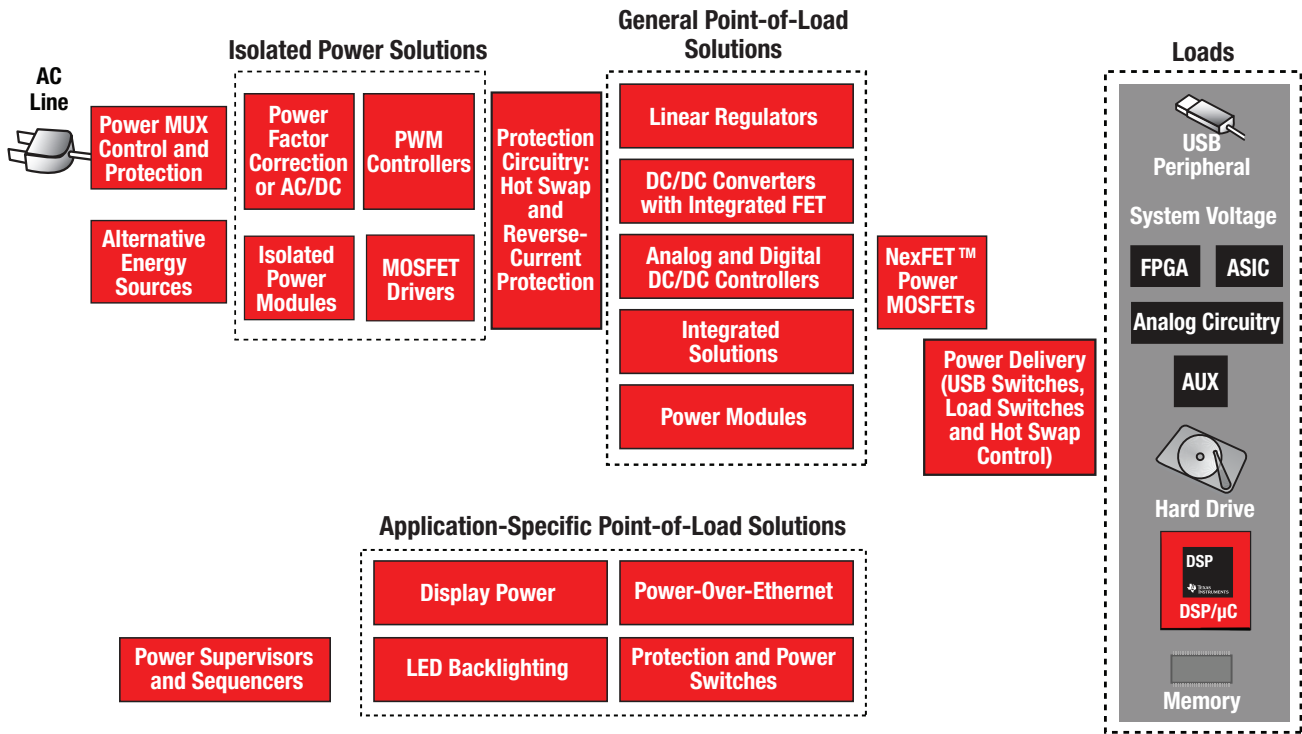

Portable Power Solutions

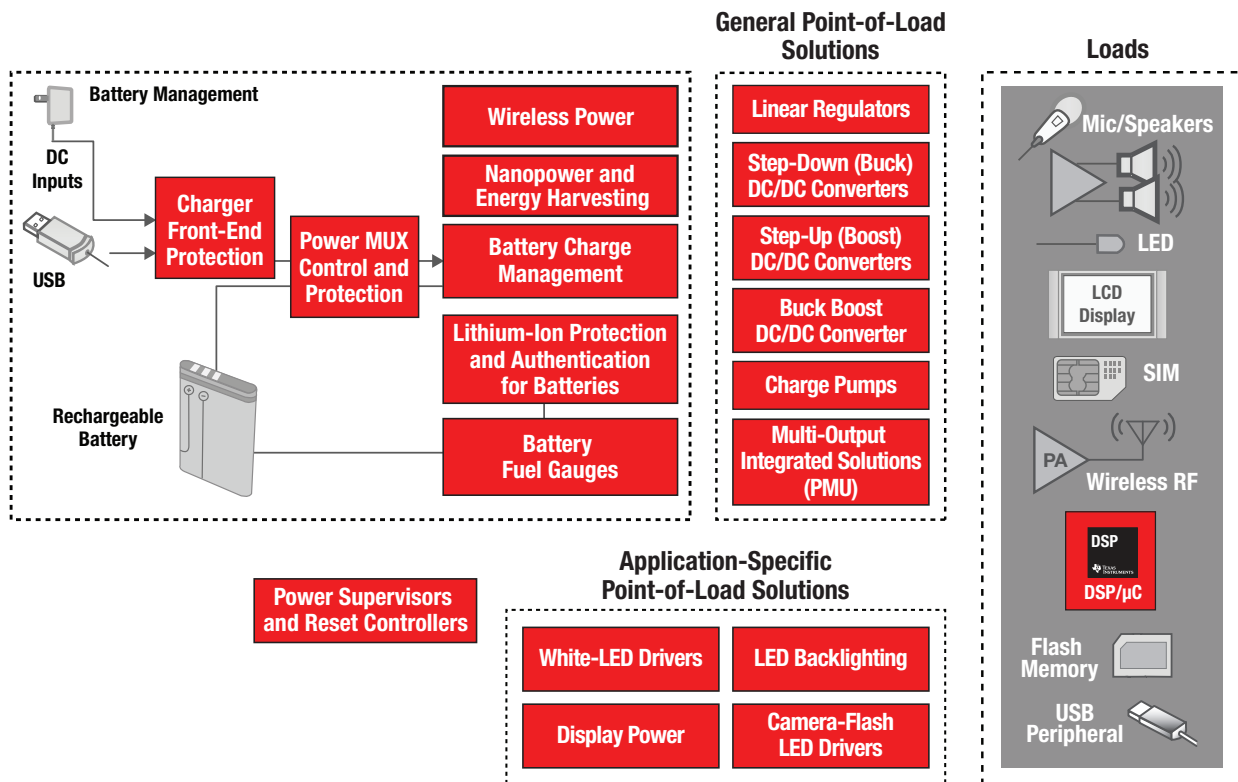

→ Overview

Power-management products from Texas Instruments (TI) continue to provide optimized power solutions for portable and line-powered designs. Applications traditionally include power supplies for computing, telecom and networking systems, digital TVs, set-top boxes, video surveillance systems and consumer electronics such as smart phones, tablets and digital cameras—to name just a few. TI continues to introduce innovative power-management products for those key markets.

However, applications are emerging that present new power-design challenges,

and TI is developing power-management solutions to meet them. We are working in partnership with developers of these new technologies to enable these concepts to become reality. Some of these emerging applications include:

- Smart meters as part of the rollout of the larger smart grid
- LED lighting—from low-power light-bulb replacements to larger high-power signage and street lighting
- Wireless charging for portable devices
- “Nano” power (solar, vibration and thermal) energy harvesting for remote sensor systems

- Off-grid solar charging for portable devices, fans, pumps and lighting
- Battery management systems for hybrid or fully electric vehicles
- Complex cellular base stations with dynamically controlled point-of-load power and ultra-low-noise RF systems
- High-performance diagnostics or test and measurement systems that require ultra-clean, high-voltage power

The block diagrams on the next few pages highlight some of these solutions.

→ Power for Smart Meters

The trend towards automated meter reading (AMR) increases the electronics content of a smart meter. One objective in designing smart meters is reducing

the amount of power they can draw from AC lines. Employing high-efficiency AC/DC flyback controllers as well as wide- V_{IN} DC/DC converters and LDO linear

regulators for the various system V_{CC} requirements provides an ideal power-supply solution.

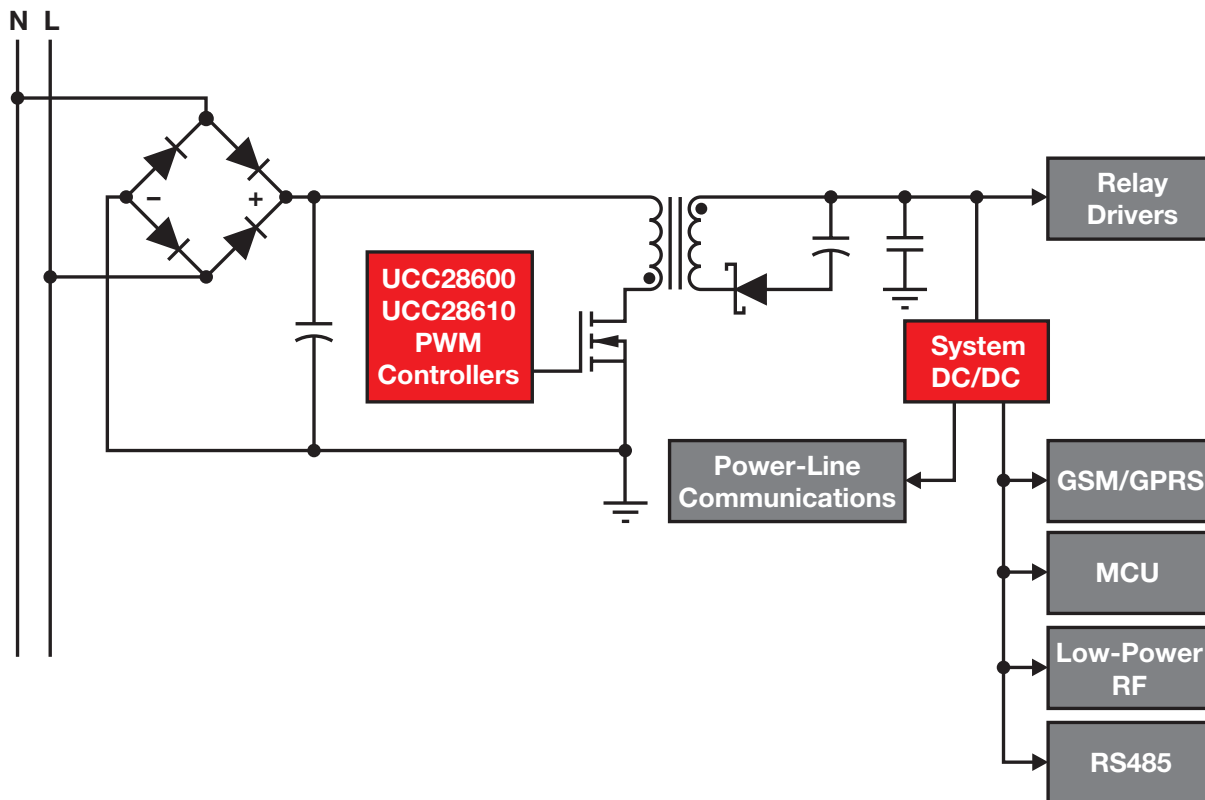

→ LED Lighting

LED technologies continue to improve efficiency, lower costs and produce more light with less power. To solve the challenges that will enable the rapid growth of solid-state LED lighting, TI offers a wide variety of LED lighting solutions such as AC/DC and DC/DC LED drivers and constant-current LED regulators. For more information, visit: www.ti.com/led

Dimmable LED Lighting Solution for Lightbulb Retrofit Applications

The TPS92210 is a driver controller for LED lighting applications that has natural power-factor correction (PFC) and advanced energy features to provide high-efficiency control.

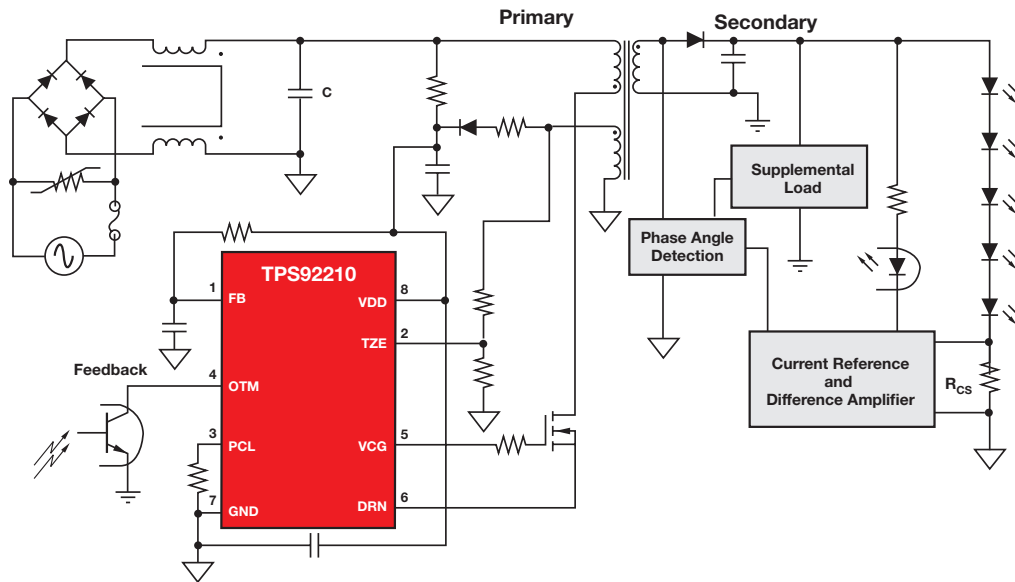

110-W SimpLEDdrive™ Solution for Street Lights and Medium-to-Large Infrastructure Lighting

The UCC28810, UCC28811 and TPS92020 supports a high-lighting application with an off-line, constant-current LED driver. The driver circuit includes AC-to-DC conversion, isolation and PFC.

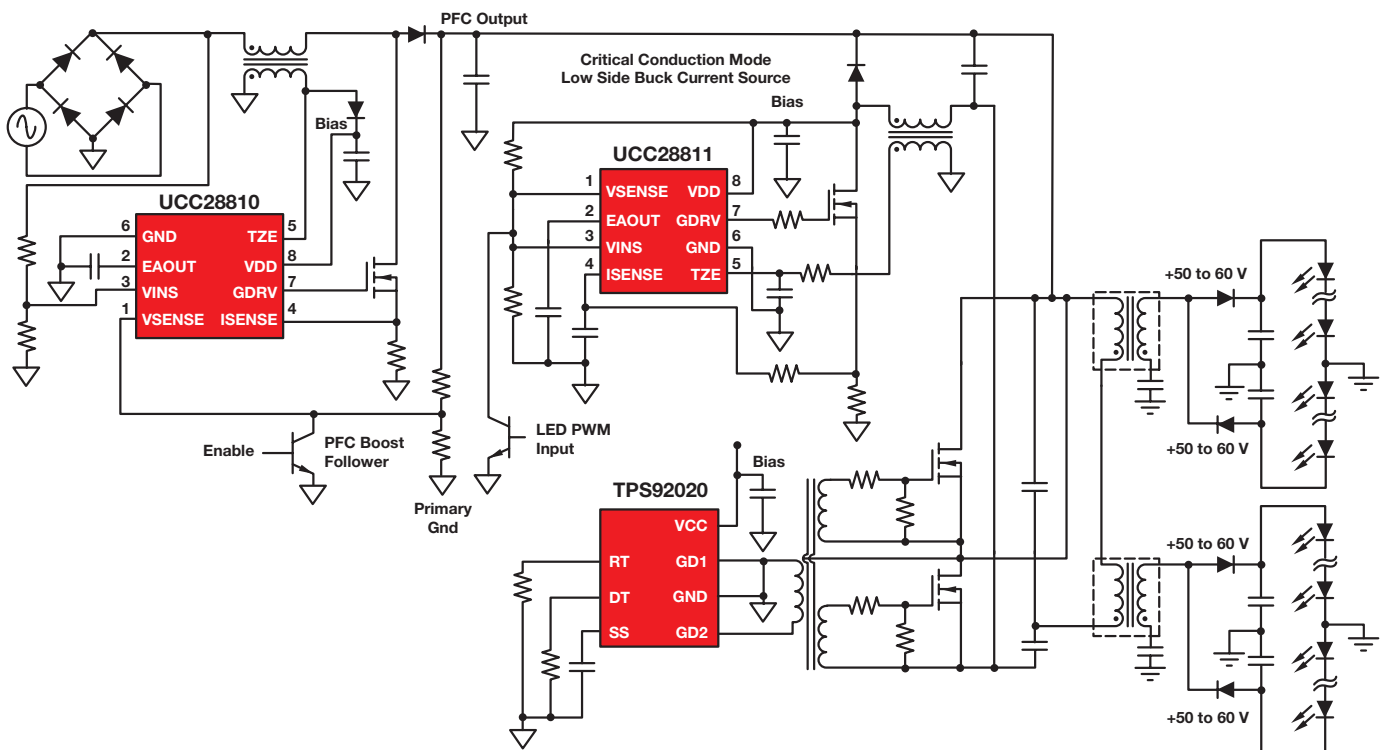

Emerging Power Applications

→ Wireless Power (bqTESLA™)

TI is leading the new wireless-power market with the very first Qi-compliant evaluation kit, called the bqTESLA150LP. The 69+ members, including TI, of the Wireless Power Consortium are setting the international standard for interoperable wireless charging with the Qi standard.

The bqTESLA150LP chipset enables customers to power their electronic devices

up to 5 W, meeting the Qi standard. The transmitter and receiver solutions that make up the bqTESLA150LP evaluation kit are ready for mass production today.

The bqTESLA150LP receiver includes the bq51013, which outputs 5 V and provides digital control and a transmitter-control communication function. Software is already programmed into the device, so no software programming is required.

The bqTESLA150LP transmitter includes the bq500110, which controls the entire transmitter.

Purchase the evaluation kit, download the user's guides and datasheets, and order samples at:

www.ti.com/wirelesspower

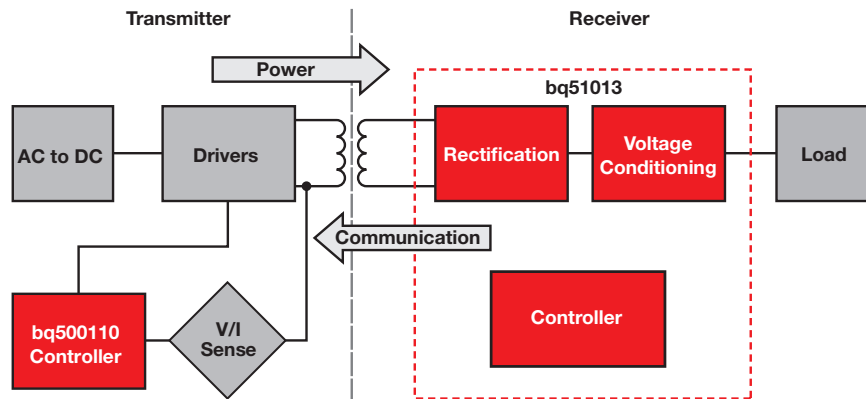

→ Energy Harvesting

As new forms of alternative (off-grid) energy are being developed, power-management technologies are required to harvest, store and regulate this power. Energy from such sources as photovoltaic panels, kinetic (vibration) MEMs and thermoelectric elements (utilizing Peltier, Thompson or Seebeck effects) presents

the challenge of converting ultra-low levels of “nano” power to more usable levels and storing the energy for later use. TI continues to develop new power-management ICs to meet these harvesting challenges, including ultra-low-power devices such as LDOs and high-efficiency boost converters and battery

chargers. These power-management devices complement TI's portfolio of low-power MCUs and RF, amplifier and sensor ICs—providing a total solution for systems powered by new forms of ultra-low-power alternative energy.

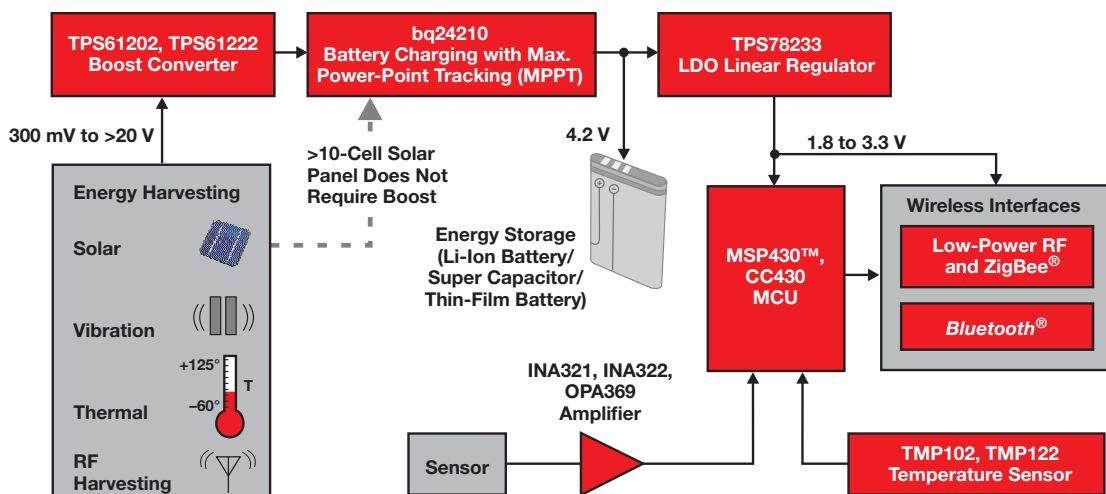

Emerging Power Applications

→ Solar Charging

Photovoltaic technologies have evolved that can now provide more cost-effective and efficient energy harvesting from the sun. Most solar harvesting today uses high-power installations that provide supplemental AC power to the home or to commercial buildings and are generally tied to the utility grid. However, much of the world is still not yet tied to the grid, or the grid is unreliable, or being tethered to the AC power supply is just not practical. In these applications, using

the sun to charge a battery that supplies power to off-grid applications is a more practical solution. For these applications, a trade-off between cost and PV efficiency is often required. Maximizing power from the panel is balanced with the cost and size of the overall system.

The diagrams below illustrate two examples of low-cost solar-charger applications where the battery charger is integrated with simple circuitry to maximize the power point from the solar

panel as well as with circuitry for load regulation. Simple solar streetlights or solar lanterns can be developed by adding devices such as LED drivers. The implementation of a USB switch with a boost converter can create a simple solar charger for portable devices. Other applications can implement motor drivers for solar-powered fans or water pumps. These are but a few of the options enabled by TI's new family of solar-charger ICs.

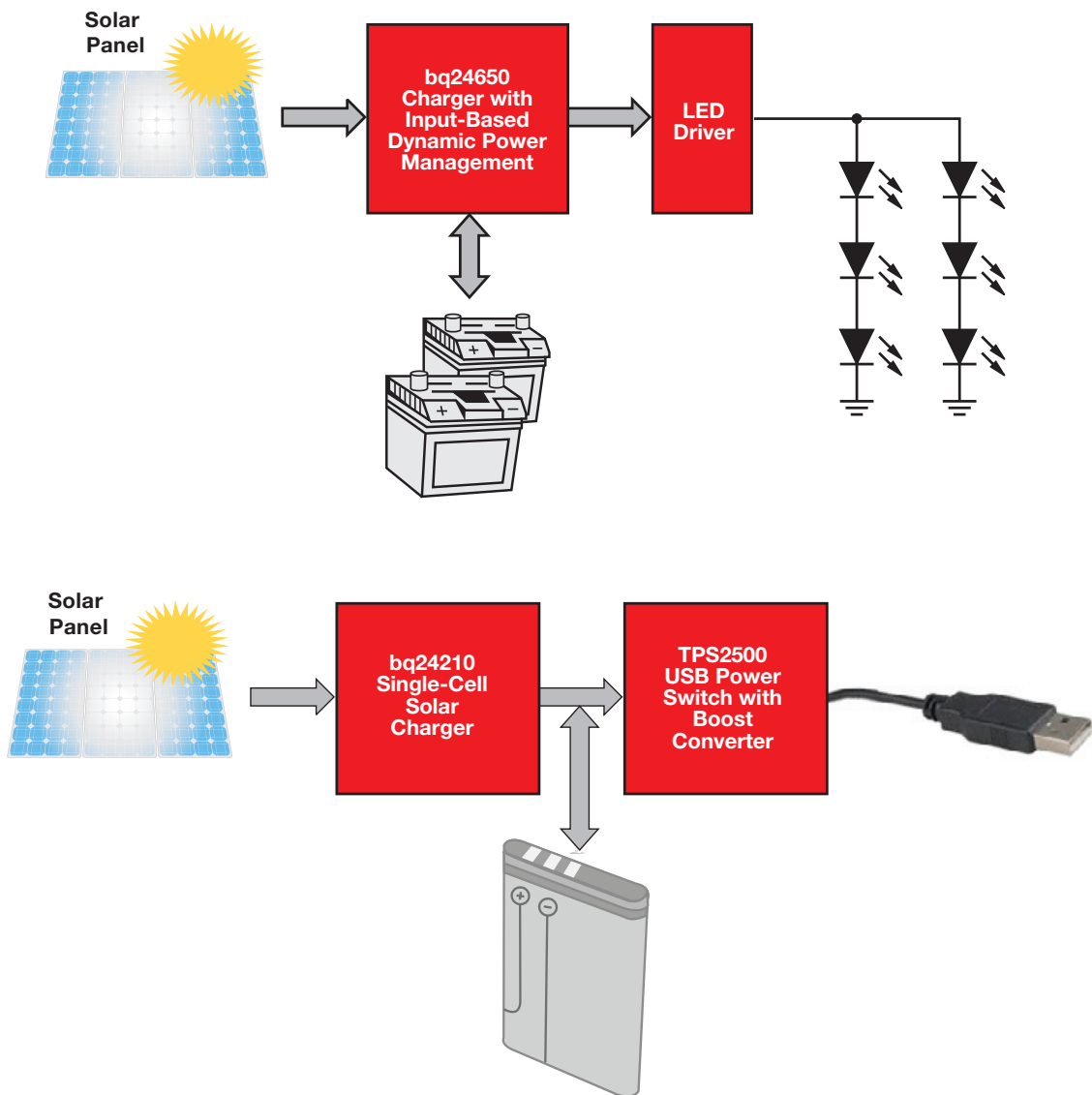

→ HEV Battery Management

The battery-management system (BMS) is a key element in the overall HEV architecture. An intelligent implementation will extend not only the battery's lifetime but also the possible range of a vehicle in fully electric drive mode, which is a

key selling point to end users. The BMS modules require battery supervision and battery cell-balancing features, often connected through different communication paths to ensure system redundancy. Built-in temperature management is

also a crucial element for a system's lifetime and safety. The complete BMS represents a highly safety-critical function; therefore, reliable communication and accurate data measurement are necessities.

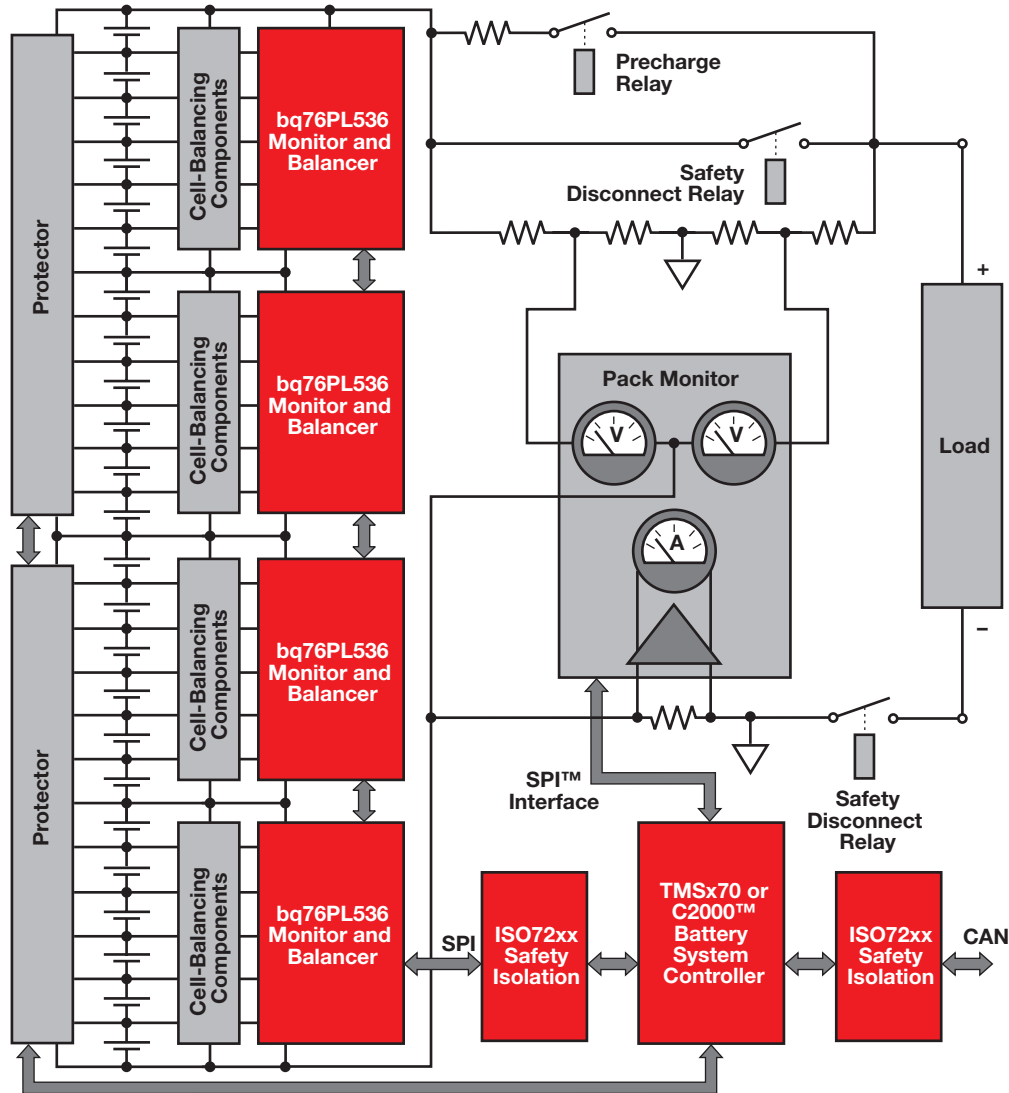

Emerging Power Applications

→ High-PSRR Telecom

Telecom and datacom applications typically employ an isolated positive or negative 48-V system to generate an intermediate bus voltage of between 12 and 3.3 V. The intermediate bus voltage is then stepped down to the point-of-load voltage with DC/DC controllers, converters, modules or linear regulators. Hot swap and sequencers provide circuit protection or monitoring of the various

voltages and currents. Digital power controllers provide the additional capability of dynamically controlling power based on system-performance feedback. TI's C2000™ family can address the firmware-based flexibility of full DSP/MCU control or a more hardware-based implementation of a fully configurable digital state machine using the UCD30K family.

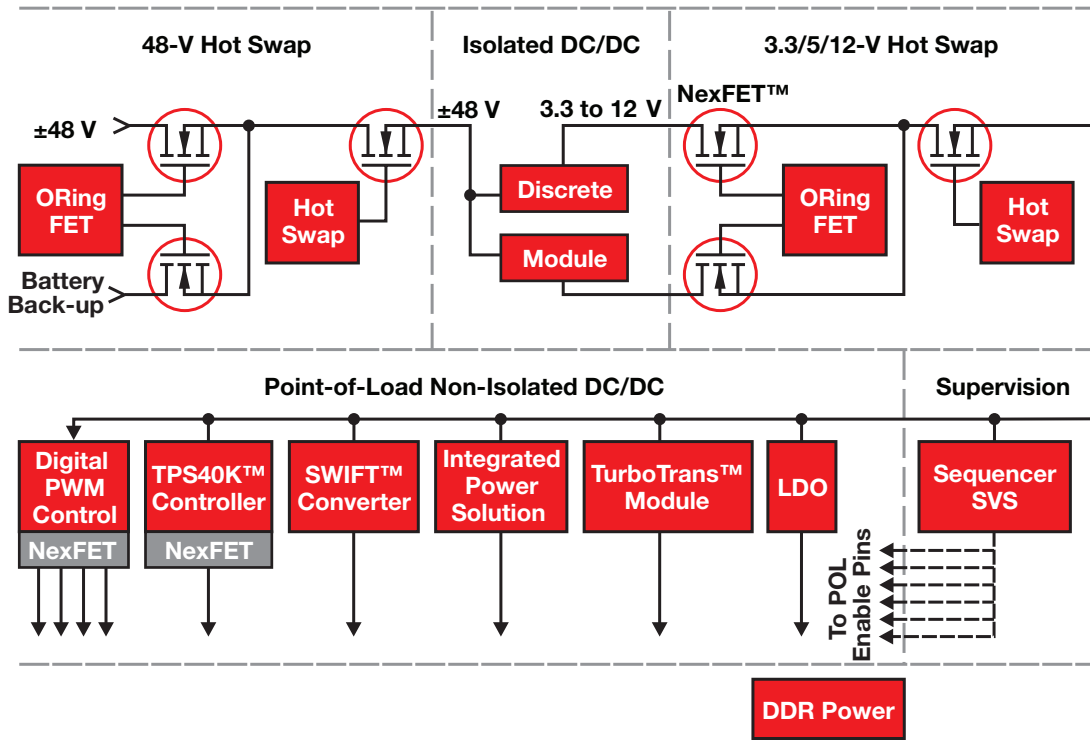

→ Overview

Texas Instruments offers a large portfolio of non-isolated DC/DC point-of-load solutions to address size, efficiency, performance or cost constraints. Our solutions range from discrete devices to integrated power solutions that contain magnetics within the IC package. Try our Power Quick Search Tool at www.ti.com/power to find the latest point-of-load solutions by simply providing the input voltage, output voltage, and output current.

Integrated Power Solutions — High power density is easily achievable with DC/DC converters that integrate magnetics into the package. TI's integrated power solutions save board space by providing a size-optimized solution with little design effort.

Step-Down DC/DC Converters — Integrated MOSFET technology has reached high levels of density over the past few years to provide higher efficiency in smaller packages. TI's DC/DC converters offer many compelling solutions up to 25 A.

Power-Management Units (PMUs) — Multiple DC/DC converters in one package simplify the power design by reducing component count. TI's PMUs integrate several inductive step-down

converters with linear regulators, charge pumps or other analog circuits such as battery chargers and an I²C interface to save space.

Step-Up Boost Converters — The datasheet specifies the current limit of the integrated power MOSFET switches. A rough estimate for the actual output current achievable is a function of the duty cycle and can be estimated with the following formula:

$$I_{OUT} = 0.65 \times I_{Switch(min)} \times (V_{IN}/V_{OUT})$$

Buck-Boost Converters — A DC/DC converter must be able to regulate the output voltage at all possible input-voltage conditions, whether V_{IN} is higher or lower than V_{OUT} . TI's single-inductor buck-boost converters integrate four power MOSFETs on-chip to save space and to seamlessly transition in between the modes of operation.

Charge Pumps — TI's family of low-voltage charge pumps provides a low-noise solution to boost the voltage without an inductor. Charge pumps achieve 90% peak efficiency and are useful for output currents under 300 mA.

Linear and Low-Dropout Regulators (LDOs) — TI's linear regulators support currents from 10 mA to 7.5 A. The

selection guide features the minimum output capacitance required as well as the key benefits, such as low quiescent current, fast transient response or low noise.

DC/DC Controllers — The output current is set by external MOSFETs, which allows the designer to optimize the efficiency and performance. Strong MOSFET drivers in TI's controllers can drive more external MOSFETs. Consider NexFET™ power MOSFETs with best-in-class $r_{DS(on)}$ and gate-charge performance.

Digital Power (Non-isolated) — TI's digital power solutions offer greater levels of performance and flexibility than a pure analog design. TI's digital-power PWM controllers and their complementary power-stage solutions and modules are well-suited for applications requiring configurability, communications, diagnostics and telemetry. Visit www.ti.com/digitalpower for more information.

Plug-In Power Modules — TI's non-isolated modules are completely integrated and board-mounted. Vertical mounting uses the smallest footprint. Surface mounting and horizontal through-hole mounting are available in most product series.

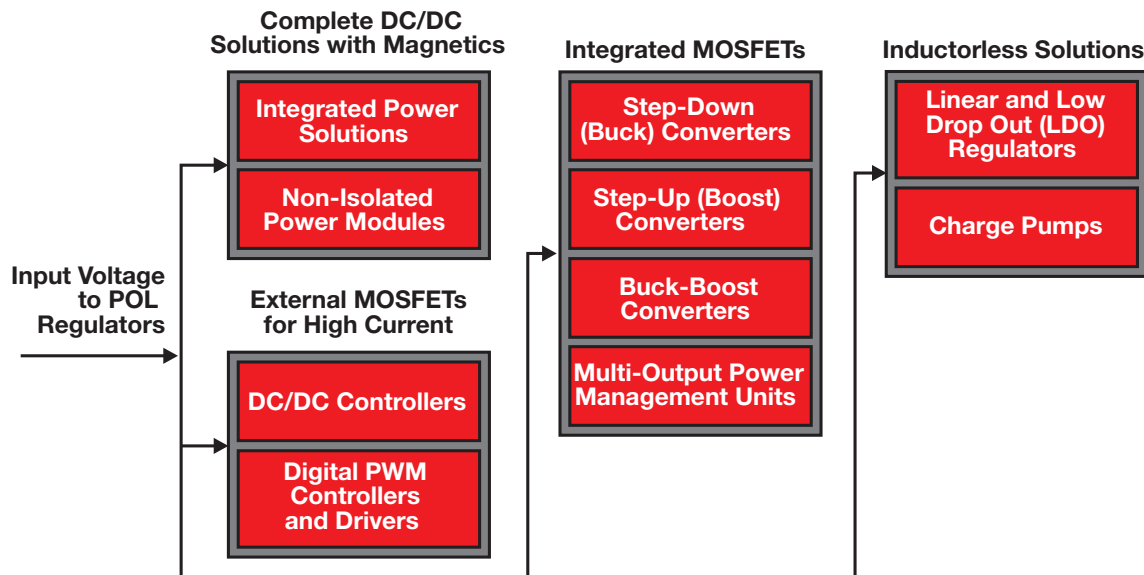

Point-of-Load Solutions

→ Integrated Power Solutions (with Built-in Inductor)

600-mA Fully Integrated Step-Down Solution

TPS82671

Get samples, datasheets, evaluation modules and app reports at: www.ti.com/sc/device/TPS82671

The TPS8267x device is a complete 600-mA, DC/DC step-down power supply intended for low-power applications. Included in the package are the switching regulator, inductor and input/output capacitors. No additional components are required to finish the design.

The TPS8267x is based on a high-frequency, synchronous step-down DC/DC converter optimized for battery-powered portable applications. The MicroSiP™ DC/DC converter operates at a regulated 5.5-MHz switching frequency and enters the power-save mode of operation at light load currents to maintain high efficiency over the entire load-current range. The PFM mode extends the battery life by reducing the quiescent current to 17 mA (typ) during light-load operation.

The TPS8267x is packaged in a compact (2.3 x 2.9-mm), low-profile (1.0-mm) BGA suitable for automated assembly by standard surface-mount equipment.

Key Features

- Simplicity of a 3-pin regulator
- Integrated inductor and capacitors
- Small size: 6.7-mm² footprint, 2.3 x 2.9 x 1 mm high
- Greater than 90% efficiency at 5.5 MHz
- Low noise: Spread spectrum, PWM frequency dithering, high PSRR and low ripple
- Input voltage: 2.3 to 4.8 V

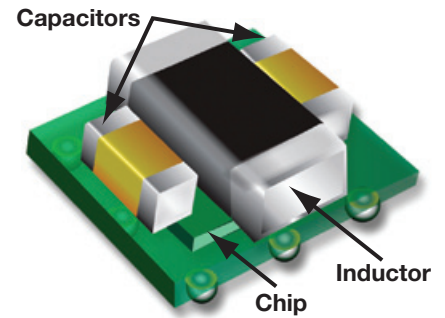

MicroSiP™ package—2.3 x 2.9 mm and low profile of 1.0 mm.

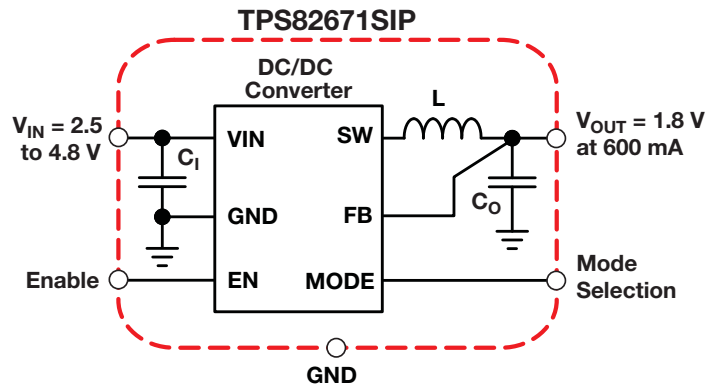

Functional diagram.

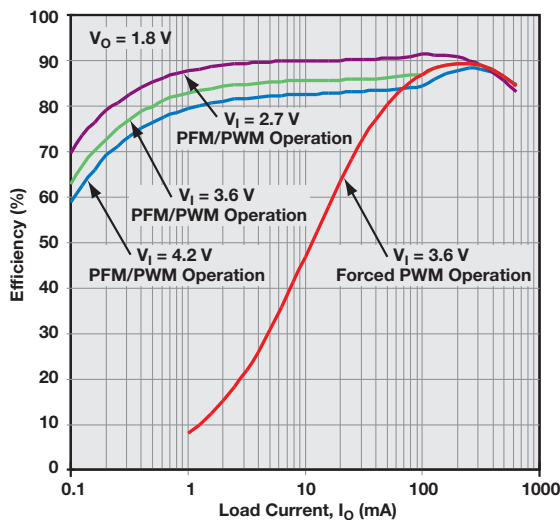

Efficiency versus load current.

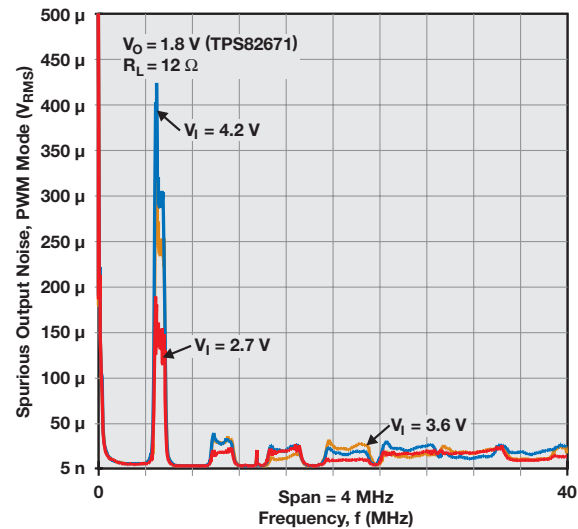

Spurious output noise in PWM mode.

Point-of-Load Solutions

→ Integrated Power Solutions (with Built-in Inductor)

4.5-V to 14.5-V Input, 6-A Synchronous Buck Integrated Power Solution

TPS84620

Get samples, datasheets, evaluation modules and app reports at: www.ti.com/sc/device/TPS84620

The TPS84620 is an integrated power solution that combines a 6-A DC/DC converter with power MOSFETs, an inductor and small passive components. The small and easy-to-use QFN package increases power density without sacrificing performance.

Key Features

- Integrated inductor and passives—only 3 external components
- Easy-to-mount 15 x 9 x 2.8-mm QFN package
- 95% peak efficiency and 13°C/W θ_{JA} thermal resistance

- Adjustable frequency, soft start and UVLO with track, clock and PG pins

Applications

- Broadband and communication infrastructure
- Automated test and medical equipment
- CompactPCI®/PCI Express®/PXI Express®
- DSP and FPGA point-of-load applications

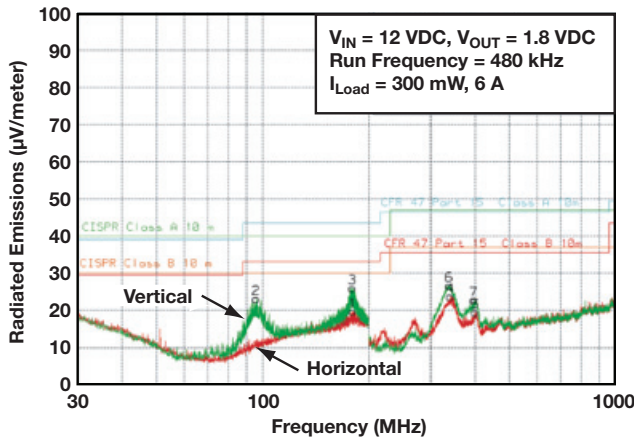
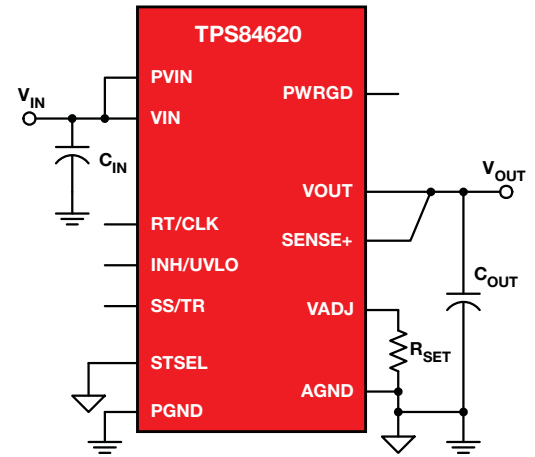

Radiated emissions 12-V input, 1.8-V output, 6-A load (EN55022 Class B).

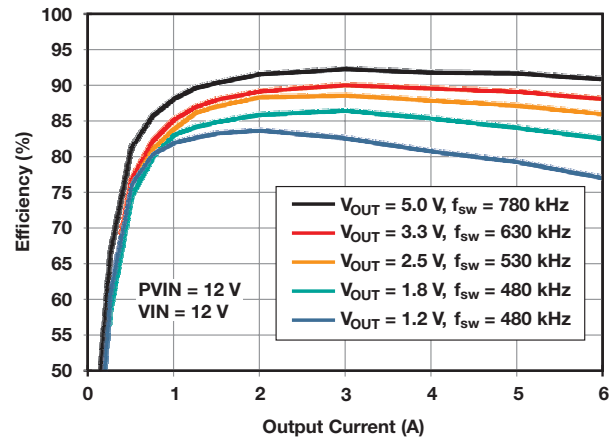

Efficiency at 12-V input.

Selection Guide

Device	I _{OUT} (mA)	V _{IN} (V)	Min V _{OUT} (V)	Max Duty Cycle (%)	Switching Frequency (kHz)	Features							Applications			EVM	Package(s)	Price*
						Power Good Pin	Sync Pin	180° Out-of-Phase Switching	Adj. Soft Start	Synchronous Rectifier	Light-Load Efficiency	External Compensation	Sequencing/Tracking	Fixed V _{OUT} Versions				
Integrated Power Solutions (L on device)																		
TPS84620	6000	4.5 to 14.5	1.2	85	480 to 780	✓	✓		✓	✓			✓		✓	QFN (9x15 mm)	7.00	

Device	I _{OUT} (mA)	V _{IN} (V)	V _{OUT} Adjustable/Fixed (V)	Peak Efficiency (%)	Switching Frequency (typ) (kHz)	Recommended Inductor Size (µH)	Quiescent Current (typ) (µA)	Shutdown Current (typ) (µA)	Low Battery	Power Good	Package(s)				EVM	Features and Differentiators	Price*
											Chipscale (WCSP)	SOT-23	QFN	MicroSip™			
Fully Integrated Solutions (L and C on device)																	
TPS82690	500	2.3 to 4.8	2.85/2.5	95	3000	—	17	0.5						8	✓		TBD
TPS82671	600	2.3 to 4.8	1.2/1.8	90	6000	—	17	0.5						8	✓	Spread spectrum	1.30

All of the above devices have undervoltage lockout and thermal protection built in.
*Suggested resale price in U.S. dollars in quantities of 1,000.

New devices are listed in **bold red**.
Preview devices are listed in **bold blue**.

Point-of-Load Solutions

→ Step-Down (Buck) Converters

Selection Guide

Device	I _{OUT} (mA)	V _{IN} (V)	Min V _{OUT} (V)	Max Duty Cycle (%)	Switching Frequency (kHz)	Features							Applications			EVM	Package(s)	Price*
						Power Good Pin	Sync Pin	180° Out-of-Phase Switching	Adj. Soft Start	Synchronous Rectifier	Light-Load Efficiency	External Compensation	Sequencing/Tracking	Fixed V _{OUT} Versions	HiRel (H) or Automotive (A) [†]			
SWIFT™ Step-Down (Buck) Regulators																		
TPS54040	500	3.5 to 42	0.8	98	100 to 2500	✓	✓		✓		✓	✓	✓		A	✓	10 HMSOP	1.35
TPS54060	500	3.5 to 60	0.8	98	100 to 2500	✓	✓		✓		✓	✓	✓		A	✓	10 HMSOP/10 SON	1.75
TPS5410	1000	5.5 to 36	1.23	87	500										H, A	✓	8 SOIC	1.60
TPS54140	1500	3.5 to 42	0.8	98	100 to 2500	✓	✓		✓		✓	✓	✓		A	✓	10 HMSOP	1.60
TPS54160	1500	3.5 to 60	0.8	98	100 to 2500	✓	✓		✓		✓	✓	✓		A	✓	10 HMSOP/10 SON	1.90
TPS54290/1/2 (dual)	1500/2500	4.5 to 18	0.8	90	300/600/1200			✓		✓			✓			✓	16 HTSSOP	2.95
TPS54218	2000	2.95 to 6.0	0.8	98	200 to 2000	✓	✓		✓	✓		✓				✓	16 QFN (3x3 mm)	1.50
TPS54225	2000	4.5 to 18	0.76	90 ¹	700	✓			✓	✓						✓	14 HTSSOP	1.45
TPS54226	2000	4.5 to 18	0.76	90 ¹	700	✓			✓	✓	✓					✓	14 HTSSOP/16 QFN	1.50
TPS54231/2/3	2000	3.5 to 28	0.8	93	570/1000/300				✓		✓	✓				✓	8 SOIC	1.25
TPS54283/6 (dual)	2000 each	4.5 to 28	0.8	90/85	300/600			✓					✓			✓	14 HTSSOP	2.40
TPS5420	2000	5.5 to 36	1.23	87	500										H, A	✓	8 SOIC	1.70
TPS54240	2500	3.5 to 42	0.8	98	100 to 2500	✓	✓		✓		✓	✓	✓		A	✓	10 HMSOP	1.90
TPS54260	2500	3.5 to 60	0.8	98	100 to 2500	✓	✓		✓		✓	✓	✓		A	✓	10 HMSOP/10 SON	2.30
TPS54318	3000	2.95 to 6.0	0.8	98	200 to 2000	✓	✓		✓	✓	✓					✓	16 QFN (3x3 mm)	2.00
TPS53311	3000	2.9 to 6.0 ²	0.6	85	1000		✓			✓	✓	✓					16 QFN (3x3 mm)	2.15
TPS54310/1/2/3/4/5/6	3000	3.0 to 6.0	0.9	90	280 to 700	✓	✓ ³		✓	✓		✓ ⁴		✓	H, A	✓	20 HTSSOP	2.25
TPS54320	3000	4.5 to 17	0.8	98	200 to 1200	✓	✓		✓	✓		✓	✓			✓	14 QFN	1.70
TPS54325	3000	4.5 to 18	0.76	90 ¹	700	✓			✓	✓						✓	14 HTSSOP	1.55
TPS54326	3000	4.5 to 18	0.76	90 ¹	700	✓			✓	✓	✓					✓	14 HTSSOP/16 QFN	1.60
TPS54331	3000	3.5 to 28	0.8	93	570				✓		✓				A	✓	8 SOIC	1.35
TPS5430	3000	5.5 to 36	1.23	87	500										H, A	✓	8 HSOIC	1.85
TPS55383/6 (dual)	3000 each	4.5 to 28	0.8	90/85	300/600			✓				✓	✓			✓	16 HTSSOP	2.65
TPS54332	3500	3.5 to 28	0.8	93	1000				✓		✓	✓				✓	8 HSOIC	1.40
TPS54418	4000	2.95 to 6.0	0.8	98	200 to 2000	✓	✓		✓	✓		✓				✓	16 QFN (3x3 mm)	2.35
TPS54425	4000	4.5 to 18	0.76	90 ¹	700	✓			✓	✓						✓	14 HTSSOP	1.75
TPS54426	4000	4.5 to 18	0.76	90 ¹	700	✓			✓	✓	✓					✓	14 HTSSOP/16 QFN	1.80
TPS54521	5000	4.5 to 17	0.8	98	200 to 900	✓	✓		✓	✓		✓	✓			✓	QFN (3.5x3.5 mm)	1.90
TPS5450	5000	5.5 to 36	1.23	87	500										H, A	✓	8 HSOIC	2.25
TPS54618	6000	2.95 to 6.0	0.8	98	200 to 2000	✓	✓		✓	✓						✓	16 QFN (3x3 mm)	2.85
TPS54610/1/2/3/4/5/6	6000	3.0 to 6.0	0.9	90	280 to 700	✓	✓ ³		✓	✓		✓ ⁴		✓	H, A	✓	28 HTSSOP	3.20
TPS54620	6000	4.5 to 17	0.8	98	200 to 1600	✓	✓		✓	✓		✓	✓			✓	QFN (3.5x3.5 mm)	2.50
TPS54917	9000	3.0 to 4.0	0.9	90	280 to 1600	✓	✓		✓	✓		✓				✓	QFN (3.5x7 mm)	3.70
TPS51315	10000	3 to 14 ⁵	0.76	100 ¹	100 to 1000					✓	✓					✓	QFN (5x7 mm)	2.65
TPS54010	14000	2.25 to 4.0	0.9	90	280 to 700	✓	✓		✓	✓		✓				✓	28 HTSSOP	4.25
TPS56121	15000	4.5 to 14	0.6	93	300/500/1000	✓			✓	✓		✓				✓	22 QFN (5x6 mm)	5.25
TPS56221	25000	4.5 to 14	0.6	93	300/500/1000	✓			✓	✓		✓				✓	22 QFN (5x6 mm)	4.35

¹Maximum V_{OUT} is 5.5 V.

²Requires 2.9- to 3.5-V bias input.

³Fixed V_{OUT} options do not have a sync pin.

⁴Adjustable versions are externally compensated.

⁵Requires 4.5- to 5.5-V bias input.

[†]Devices qualified for HiRel (H) or Automotive (A) applications are available. Certain voltage options are not available. Different pricing may apply.

*Suggested resale price in U.S. dollars in quantities of 1,000.

New devices are listed in **bold red**.

Point-of-Load Solutions

→ Step-Down (Buck) Converters

Selection Guide (Continued)

Device	I _{OUT} (mA)	V _{IN} (V)	V _{OUT} Adjustable/Fixed (V)	Peak Efficiency (%)	Switching Frequency (typ) (kHz)	Recommended Inductor Size (μH)	Quiescent Current (typ) (μA)	Shutdown Current (typ) (μA)	Low Battery	Power Good	Package(s)				EVM	Features and Differentiators	HiRel (H) or Automotive (A) [†]	Price*
											Chipscale (WCSP)	SOT-23	QFN	MicroSIP™				
General Purpose, Step-Down (Buck) Regulators — Small, Efficient, Low I_Q																		
TPS62200	300	2.5 to 6.0	Adj./1.5 to 3.3	95	1000	10	15	0.1				6			✓			0.70
TPS62240	300	2.0 to 6.0	Adj./1.2/1.8	95	2250	2.2	15	0.1				5	6		✓			0.75
TPS62220	400	2.5 to 6.0	Adj./1.2 to 2.3	95	1250	4.7	15	0.1				6			✓			0.80
TPS62260	600	2.0 to 6.0	Adj./1.2/1.8	95	2250	2.2	15	0.1				5	6		✓			0.85
TPS62250	700	2.0 to 6.0	Adjustable	95	2250	2.2	15	0.1					6			USB applications	A	1.10
TPS62290	1000	2.3 to 6.0	Adj./1.8/3.3	95	2250	2.2	15	0.1					6		✓		A	1.15
TPS62040	1200	2.5 to 6.0	Adj./1.5/1.6/1.8/3.3	95	1250	6.2	18	0.1					10		✓	MSOP-10 package		1.40
TPS62080	1200	2.3 to 6.0	Adj./1.8/3.3		3000		5			✓			8		✓	Snooze mode, active discharge		TBD
TPS62750	1300	2.9 to 6.0	Adjustable	92	2250	2.2	745	0.3					10		✓	Progr. input current limit		1.25
TPS62510	1500	1.8 to 3.8	Adjustable	97	1500	2.2	18	0.1					10		✓	Output voltage tracking		1.60
TPS62060	1600	2.3 to 6.0	Adj./1.8/3.3	94	3000	1.0	18	0.1					8		✓			1.35
TPS62065	2000	2.3 to 6.0	Adjustable	94	3000	1.0	18	0.1					8		✓			1.55
TPS62067	2000	2.9 to 6.0	Adjustable	97	3000	1.0	18	0.1		✓			8		✓			1.65
General Purpose, Step-Down (Buck) Regulators — Value Line, Relaxed Specification																		
TPS62560	600	2.5 to 5.5	Adj./1.8	95	2250	2.2	15	0.1				5	6		✓	3% V _{OUT} tolerance		0.50
TPS62590	1000	2.5 to 5.5	Adjustable	95	2250	2.2	15	0.1					6		✓	3% V _{OUT} tolerance	A	0.85
TLV62080	1200	2.3 to 6.0	Adj./1.8/3.3		3000		25			✓			8					TBD
TLV62065	2000	2.9 to 6.0	Adjustable	97	3000	1	18	0.1					8					1.20
Extended Input Voltage Range																		
TPS62120	75	2.0 to 15	Adjustable	96	800	22	11	0.3		✓		8			✓	Ext. UVLO hysteresis		0.95
TPS62122	75	2.0 to 15	Adjustable	96	800	22	11	0.3					6		✓	Ext. UVLO hysteresis		0.90
TPS62170	500	3.0 to 17	Adj./1.8/3.3/5.0		3000					✓			8		✓			TBD
TPS62050	800	2.7 to 10.0	Adj./1.5/1.8/3.3	95	850	10	12	1.5	✓	✓					✓	MSOP-10 package		1.45
TPS62150	1000	3.0 to 17	Adj./1.8/3.3/5.0		3000					✓			16		✓	SS, tracking, 2-pin VID		TBD
TPS62160	1000	3.0 to 17	Adj./1.8/3.3/5.0		3000					✓			8		✓			TBD
TPS62110	1500	3.1 to 17	Adj./3.3/5.0	95	1000	6.8	18	1.5	✓	✓			16		✓		A, H	1.35
TPS62140	2000	3.0 to 17	Adj./1.8/3.3/5.0		3000					✓			16		✓	SS, tracking, 2-pin VID		TBD
TPS62130	3000	3.0 to 17	Adj./1.8/3.3/5.0		3000					✓			16		✓	SS, tracking, 2-pin VID		TBD
Dual Output, 180° Out-of-Phase																		
TPS62400	400 + 600	2.5 to 6.0	Adj./1.1 to 1.9/3.3	95	2250	3.3	30	0.1					10			EasyScale™ interface		1.05
TPS62410	800 + 800	2.6 to 6.0	Adjustable	95	2250	3.3	30	0.1					10			EasyScale interface	A	1.30
TPS62420	600 + 1000	2.6 to 6.0	Adjustable	95	2250	3.3	30	0.1					10		✓	EasyScale interface	A	1.30
Smallest Solution Size, High Switching Frequency																		
TPS62612	350	2.3 to 5.5	1.2/1.5/1.8/2.15	90	6000	0.47	31	0.2				6						0.80
TPS62690	350	2.3 to 5.5	1.2/1.8/2.9	95	3000	1.0	17	0.2				6				Spread spectrum		TBD
TPS62230	500	2.05 to 6.0	1.0 to 3.3	94	3000	1	22	0.1					6		✓	Up to 90-dB PSRR		0.50
TPS62674	500	2.3 to 5.5	1.2/1.26/1.8	92	6000	0.47	17	0.2				6			✓	Spread spectrum		0.90
TPS62620	600	2.3 to 5.5	1.82/1.8/1.5/1.2	90	6000	0.47	31	0.2				6			✓			0.80
TPS62660	1000	2.3 to 5.5	1.2/1.8	91	6000	0.47	31	0.2				6			✓	Active C-discharge		1.30
Dynamic Voltage Scaling																		
TPS62270	400	2.0 to 6.0	1.15/0.9-3.3/ 2.1-3.3/2.5	95	2250	2.2	15	0.1					6		✓	Vsel pin		0.80
TPS62700	650	2.5 to 6.0	Adjustable	90	2000	3.3	10	0.01				8			✓	Vcon pin		0.90
TPS62650	800	2.3 to 5.5	Adjustable	86	6000	0.47	38	0.5				9				I ² C Interface		1.10
TPS62360	3000	2.5 to 5.5	Adjustable		3000	1	42					16			✓	I ² C interface, remote sense		TBD

All of the above devices have undervoltage lockout and thermal protection built in.

[†]Devices qualified for HiRel (H) or Automotive (A) applications are available. Certain voltage options are not available. Different pricing may apply.

*Suggested resale price in U.S. dollars in quantities of 1,000.

New devices are listed in **bold red**.

Preview devices are listed in **bold blue**.

Point-of-Load Solutions

→ Step-Up (Boost) Converters

DC/DC Step-Up Converters (Integrated Switch) Family of Products

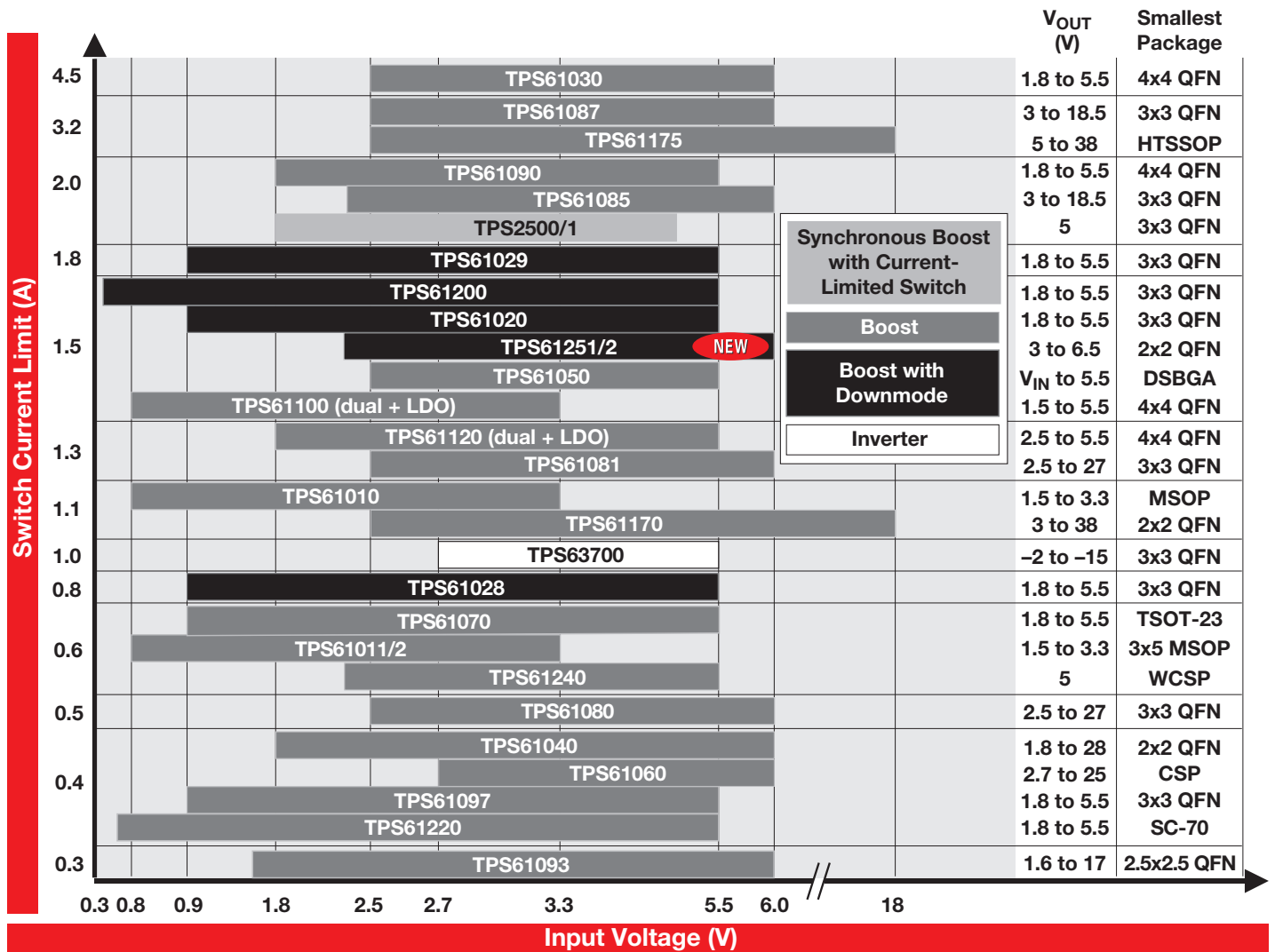

→ Step-Up (Boost) Converters

3.5-MHz, 1.5-A Current Limit, 92% Efficient Boost Converter for Battery-Backup Charging

NEW

TPS61251

Get samples, datasheets and evaluation modules at: www.ti.com/sc/device/TPS61251

The TPS61251 is a boost converter with a programmable average-input current limit that will protect the input and avoid overload. This limit is set up with an external resistor and is determined by the input source (for example, a USB bus cannot deliver more than 500 mA by specification). The TPS61251 can charge up bulk capacitors meant to store energy (as the input current is limited) and can provide high pulses of output current. The device implements an enhanced Power Save mode, called snooze mode, with very low quiescent current, resulting in very high efficiency across the load range (especially at very light loads). It features load disconnect to avoid any return path for the current when the device is shut down.

Key Features

- Resistor-programmable input-current-limit protection:
 - $\pm 10\%$ current accuracy at 500 mA over full temperature range
 - Programmable from 100 mA up to 1500 mA
- Snooze mode draws only 2 μ A of quiescent current (typical)
- Designed to charge large capacitor values in the farad range
- Power Good indicates appropriate output-voltage level even in shutdown
- V_{IN} range from 2.3 to 6.0 V
- Adjustable output voltage up to 6.5 V
- 100% duty-cycle mode when $V_{IN} > V_{OUT}$
- Load disconnect and reverse-current protection

- Short-circuit protection
- Typical operating frequency: 3.5 MHz
- Available in a 2x2-mm QFN-8 package

Applications

- Current-limited applications with high peak-current loads (SSDs, PCMCIA Tx bursts, memory, GPRS/GSM Tx)
- Battery-backup applications
- Applications powered by single-cell Li-ion battery
- Audio applications
- RF-PA buffer

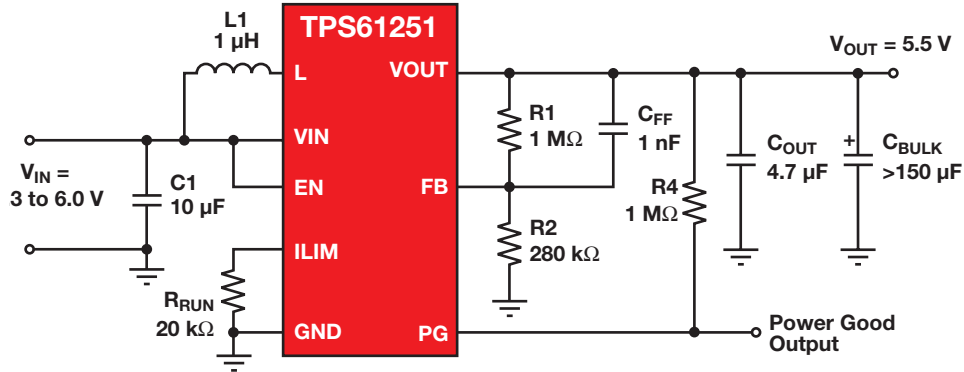

TPS61251 typical application.

Point-of-Load Solutions

→ Step-Up (Boost) Converters

Selection Guide

Device	I _{OUT} (mA) ¹	Switch Current Limit (typ) (mA)	V _{IN} (V)	V _{OUT} Adj. (V)	V _{OUT} Fixed (V)	Peak Efficiency (%)	Switching Frequency (typ) (kHz)	Recommended Inductor Size (μH)	Quiescent Current (typ) (μA)	Shutdown Current (typ) (μA)	Integrated LDO I _{OUT} (mA)/V _{OUT} (V)	Low Battery	Power Good	Undervoltage Lockout	Thermal and/or Short-Circuit Protection	Package(s)						EVM	HiRel (H) or Automotive (A) [†]	Price*		
																WCGSP (Chip scale)	SOT-23	MSOP	SON	QFN	TSSOP				SOIC	
Step-Up Regulators — Up to 6-A Switch Limit																										
TPS61260/61	50	300	0.8 to 4.0	1.8 to 4.0	3.3	95	2.3	4.7	5	0.1	—			✓	✓					6		✓		TBD		
TPS61220/21/22	50	400	0.7 to 5.5	1.8 to 5.5	3.3/5	95	—	4.7	5.5	0.2	—			✓	✓							✓		0.65		
TPS61041	50	250	1.8 to 6.0	V _{IN} to 28	—	87	1000	10	28	0.1	—			✓	✓					5		✓	A	0.65		
TPS61040	90	400	1.8 to 6.0	V _{IN} to 28	—	87	1000	10	28	0.1	—			✓	✓					5		✓	A	0.70		
TPS61011/2/3	100	480/560/930	0.8 to 3.3	—	1.5/1.8/2.5	95	500	10	36	1	—	✓		✓	✓					10				1.10		
TL497A	—	500	4.5 to 12	(V _{IN} + 2) to 30	—	85	—	—	11 mA	6000	—										14	14		0.86		
TPS61097-33	150	350	0.9 to 5.5	—	3.3	90	—	10	4	0.005	—			✓	✓					5		6		0.75		
TPS61080	—	500	2.5 to 6.0	V _{IN} to 27	—	87	1200	4.7	—	—	—				✓								✓	1.35		
TPS61014/5/6	200	1000/1100/1130	0.8 to 3.3	—	2.8/3/3.3	95	500	10	36	1	—	✓		✓	✓									1.10		
TPS61010	200	1130	0.8 to 3.3	1.5 to 3.3	—	95	500	10	36	1	—	✓		✓	✓								✓	1.10		
TPS61028	200	800	0.9 to 5.5	1.8 to 5.5	—	96	720	6.8	25	0.1	—	✓		✓	✓						10		✓	0.85		
TPS61070/1/2/3	250	700	0.9 to 5.5	1.8 to 5.5	—	90	1200 ²	4.7	19	1	—			✓	✓					6			A	0.80		
TPS61093	300	1100 ³	1.6 to 6	V _{IN} to 17	—	88	1200	10	0.9 mA	1	—			✓	✓							10		✓	1.30	
TPS61081	450	1200	2.5 to 6.0	V _{IN} to 27	—	87	1200	4.7	—	—	—				✓	✓						6		✓	1.45	
TPS61240/41	450	600/700	2.3 to 5.5	—	5	90	3500	1	30	1.5	—			✓	✓					6		6	✓	A	0.80	
TPS61170	500	1200	3.0 to 18	V _{IN} to 38	—	93	1200	10	—	1	—				✓	✓								✓	1.40	
TPS61020	500	1500	0.9 to 5.5	1.8 to 5.5	—	96	720	6.8	25	0.1	—	✓		✓	✓							10		✓	0.95	
TPS61024/5/7	500	1500	0.9 to 5.5	1.8 to 5.5	3/3.3/5	96	720	6.8	25	0.1	—	✓		✓	✓							10		✓	0.95	
TPS61251	500	1500	2.3 to 6	3 to 6	—	92	3500	1	30	0.85	—		✓	✓	✓							8		✓	1.60	
TPS61252	500	1500	2.3 to 6	3 to 6	—	92	3500	1	30	0.85	—		✓	✓	✓							8		✓	1.25	
TPS61026/9	600	1800	0.9 to 5.5	1.8 to 5.5	—	96	720	6.8	25	0.1	—	✓		✓	✓							10		✓	1.10	
TPS61090	700	2200	1.8 to 5.5	1.8 to 5.5	—	96	600	6.8	20	0.1	—	✓		✓	✓							16		✓	1.70	
TPS61091/2	700	2000	1.8 to 5.5	—	3.3/5	96	600	6.8	20	0.1	—	✓		✓	✓							16		✓	1.70	
MC34063A	750	1500	3 to 40	3 to 39.5	—	—	100	—	—	1	—				✓	✓						8	8	✓	0.21	
TPS61200/1/2	800	1500	0.3 to 5.5	0 to V _{IN}	3.3/5	90	1250	2.2	50	1	—			✓	✓							10		✓	0.95	
TPS61030/1/2	1000	4500	1.8 to 5.5	1.8 to 5.5	3.3/5	96	600	6.8	20	0.1	—	✓		✓	✓							16	16	✓	2.10	
TPS61175	1300	3800	2.9 to 18	V _{IN} to 38	—	95	2200	10	—	<1.5	—			✓	✓							14		✓	1.80	
Step-Up (Boost) Regulators with Integrated LDO (Dual Output)																										
TL499A	100	—	1.1 to 10	2.9 to 30	—	85	—	—	—	15	100/Adj.											8			1.08	
TPS61100	200	1500	0.8 to 3.3	1.5 to 5.5	—	95	500	10	65	0.5	120/Adj.	✓	✓	✓	✓							24	20	✓	1.50	
TPS61103/6/7	200	1500	0.8 to 3.3	—	3.3/3.3/3.3	95	500	10	65	0.5	120/Adj., 1.5, 1.8	✓	✓	✓	✓							24	20		1.50	
TPS61120	500	1300	1.8 to 5.5	2.5 to 5.5	—	95	500	10	40	0.2	200/Adj.	✓	✓	✓	✓							16	16	✓	1.65	
TPS61121/2	500	1300	1.8 to 5.5	—	3.3/3.6	95	500	10	40	0.2	200/1.5, 3.3	✓	✓	✓	✓							16	16		1.65	
Inverting Regulators																										
TL497A	—	500	4.5 to 12	-1.2 to -25	—	85	—	—	11 mA	6000	—											14	14		0.86	
TPS63700	360	1000	2.7 to 5.5	-2 to -15	—	84	1400	4.7	—	0.014	—											10		✓	1.65	
MC34063A	750	1500	3 to 38	-1.25 to -36.3	—	—	100	—	0.330 mA	—	—			✓	✓							8	8	✓	0.21	
TPS54160	750	2500	3.5 to 60	-0.8 to -58	—	98	100 to 2500	150	116	1.3	—		✓	✓	✓							10	10	✓	A	1.90
TPS5430	1500	4000	5.5 to 36	-1.23 to -31	—	87	500	15	4.4 mA	50	—			✓	✓							8		✓	H, A	1.85

¹For boost converters, max. I_{OUT} can be estimated with 0.65 × switch limit × (V_{IN}/V_{OUT}).

²PWM/PPM (TPS61070); PWM only (TPS61071).

³Output current is limited to 300 mA.

[†]Devices qualified for HiRel (H) or Automotive (A) applications are available. Certain voltage options are not available. Different pricing may apply.

*Suggested resale price in U.S. dollars in quantities of 1,000.

New devices are listed in bold red.
Preview devices are listed in bold blue.

Point-of-Load Solutions

➔ Buck-Boost Converters

Small, Efficient 4-A Switch Buck-Boost Converter

TPS63020

NEW

Get samples and datasheets at: www.ti.com/sc/device/TPS63020

The TPS63020 is the industry's smallest and highest-performance buck-boost converter with a 4-A switch and up to 96% efficiency. The buck-boost device operates with a wide input-voltage range of 1.8 V to 5.5 V while maintaining excellent light load efficiency. The single-inductor, 2.4-MHz TPS63020 converter comes in a 3x4x1-mm package and can achieve a complete DC/DC converter solution of 100 mm², more than 60% smaller than that of the competition.

Key Features

- High output-current capability: 3 A at 3.3 V in step-down mode and more than 2.0 A at 3.3 V in boost mode (typical)

- Dynamic input-current limit and smart Power Good effectively protect the circuit and system
- Power Save mode maintains high efficiency at light load
- Supports single-cell lithium-based or 2- or 3-cell alkaline, NiCd or NiMH batteries

- DSC, camcorder
- Industrial metering equipment, PDAs
- Personal medical products
- Tablets

Applications

- Products powered by single-cell lithium-based or 2- or 3-cell alkaline, NiCd or NiMH batteries
- UMPC, MID
- Digital media players
- Cellular phones/smartphones

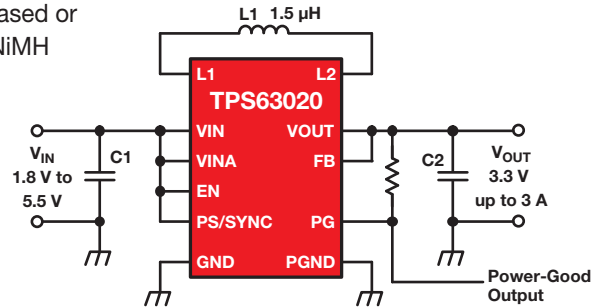

TPS63020 typical application.

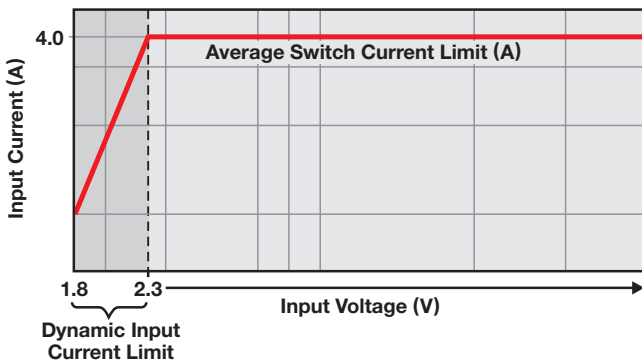

Average switch-current limit.

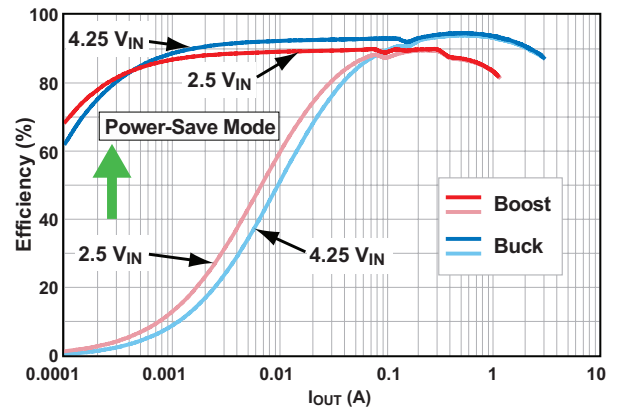

TPS63020 efficiency at 3.3 V.

Selection Guide

Device	I _{OUT} (mA)	Switch-Current Limit (typ) (mA)	V _{IN} (V)	V _{OUT} Adj. (V)	V _{OUT} Fixed (V)	Peak Efficiency (%)	Switching Frequency (typ) (kHz)	Recommended Inductor Size (μH)	Quiescent Current (typ) (μA)	Shutdown Current (typ) (μA)	Integrated LDO I _{OUT} (mA)/V _{OUT} (V)	Low Battery	Power Good	Undervoltage Lockout	Thermal and/or Short-Circuit Protection	Package(s)			HiRel (H) or Automotive (A) [†]	Price*
																WCSP (Chip scale)	QFN	TSSOP		
TPS61130	300	1300	1.8 to 5.5	2.5 to 5.5	—	90	500	10	40	0.2	200/Adj.	✓	✓	✓	✓	16	16	✓	—	1.55
TPS61131/2	300	1300	1.8 to 5.5	—	3.3/3.3	90	500	10	40	0.2	200/1.5, 3.3	✓	✓	✓	✓	16	16	✓	—	1.55
TPS63030/31	800	1000	1.8 to 5.5	1.2 to 5.5	3.3	96	2400	1.5	25	0.1	—	✓	✓	✓	✓	10	—	✓	—	1.20
TPS63000/1/2	1200	1800	1.8 to 5.5	1.2 to 5.5	3.3/5.0	90	1400	2.2	30	0.1	—	✓	✓	✓	✓	10	—	✓	A	1.50
TPS63010/11/12	1200	2200	2 to 5.5	1.2 to 5.5	3.3/3.4/2.8/2.9	96	2400	1.5	30	0.1	—	✓	✓	✓	✓	20	—	✓	—	1.50
TPS63060/1	1200	1800	2.5 to 12	2.5 to 12	5	93	2400	2.2	50	—	—	✓	✓	✓	✓	10	—	—	—	—
TPS63020	3000	4000	1.8 to 5.5	1.2 to 5.5	3.3	96	2400	1.5	30	0.1	—	✓	✓	✓	✓	14	—	✓	—	2.50

[†] Devices qualified for HiRel (H) or Automotive (A) applications are available. Certain voltage options are not available. Different pricing may apply.

*Suggested resale price in U.S. dollars in quantities of 1,000.

New devices are listed in **bold red**.
Preview devices are listed in **bold blue**.

Point-of-Load Solutions

→ Linear and Low Dropout (LDO) Regulators

New Wide- V_{IN} Linear Regulators Remove Switching Noise

TPS7A3001 and TPS7A4901

Get samples, datasheets, evaluation modules and app reports at: www.ti.com/sc/device/TPS7A3001 or www.ti.com/sc/device/TPS7A4901

The waveforms show two examples of connecting an LDO to the output of a switching DC/DC converter with magnetics, which improves the ripple voltage by removing inherent switching noise. The voltage can now be used in noise-sensitive applications to greatly increase the performance of analog sensing circuitry.

The wide-input-voltage TPS54060 DC/DC converter shown in the block diagram is configured in an inverting buck/boost

topology with an off-the-shelf coupled inductor to generate a positive and negative output voltage. Linear regulators TPS7A4901 and TPS7A3001 provide clean positive and negative power to highly noise-sensitive analog circuitry.

Key Features

- Wide input voltages:
 - TPS7A3001: -3.0 to -36 V
 - TPS7A4901: +3.0 to +36 V
- 1.5% nominal accuracy
- Stable with >2.2- μF ceramic output capacitor

- Low noise/high PSRR:
 - Output noise as low as 16 μV_{RMS}
 - PSRR of 72 dB at 1 kHz and 55 dB at 10 to 700 kHz

Key Benefits

- Better precision for VCOs, PLLs and ADCs
- Smaller size and lower cost than tantalums
- Improved dynamic range in RF applications, filters and handling DC/DC spikes

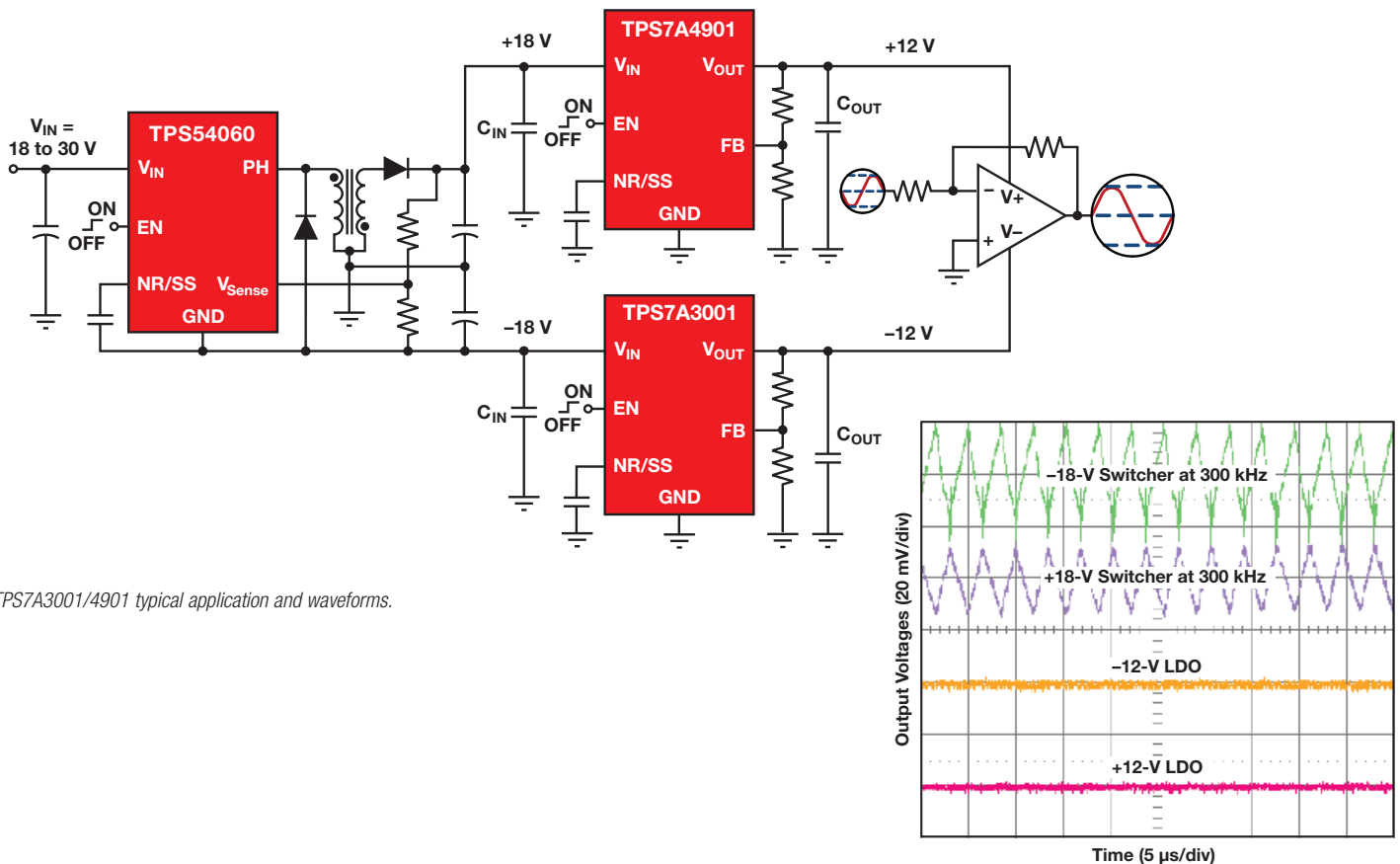

TPS7A3001/4901 typical application and waveforms.

Point-of-Load Solutions

Linear and Low Dropout (LDO) Regulators

Low Dropout (LDO) Regulators Selection Guide

Device ¹	Min V _{IN}	Max V _{IN}	I _O (mA)	V _{DO} at I _O (mV)	I _q (µA)	Output Options		Accuracy (%)	Package(s)											Features ²	C ₀ ³	Comments	HiRel (H) or Automotive (A) [†]	Price*														
						Fixed Voltage (V)	Adj. (V)		WCSP	SC70	SOT23	SOT89	MSOP	DFN	S08	SOT23	PWP	TO220	PW						TO263	TO252												
Positive Voltage, Single Output Devices																																						
TPS797xx	1.8	5.5	50	105	1.2	1.8, 2.85, 3.0, 3.3	—	4	✓									PG	1 µF, C	MSP430™; low I _q	H, A	0.34																
TPS715xx	2.5	24	50	415	3.2	1.8, 1.9, 2.3, 2.5, 3.0, 3.3, 4.5, 5.0	1.2 to 15	4	✓									—	1 µF, C	Wide V _{IN} , low I _q	H, A	0.34																
TPS7A40xx	7.0	100	50	800	25	—	1.2 to 90	1				✓						EN	4.7 µF, C	High V _{IN} , low I _q		1.50																
TPS714xx	2.5	10	80	620	3.2	3.3	1.2 to 8.8		✓				✓					—	1 µF, C	Wide V _{IN} , low I _q , low cost		0.28																
TPS715Axx	2.5	24	80	670	3.2	3.3	1.2 to 15	4					✓					—	1 µF, C	Wide V _{IN} , low I _q		0.44																
TLV704xx	2.5	24	100	840	3.2	3.0, 3.3	—	2		✓	✓							—	1 µF, C	Wide V _{IN} , low I _q		0.25																
TPS789xx	2.7	13.5	100	115	18	1.5, 1.8, 2.5, 2.8, 3.0	—	3		✓								/EN	4.7 µF, T	Low I _q and high V _{IN}		0.30																
TPS769xx	2.7	10	100	70	18	1.2, 1.5, 1.8, 2.5, 2.7, 2.8, 3.0, 3.3, 5.0	1.2 to 5.5	3		✓								/EN	4.7 µF, T	Low cost	H, A	0.29																
LP2950	2.3	30	100	380	75	3.0, 3.3, 5.0	—	1										—	1 µF, C	Available in TO92 and TO252		0.27																
LP2981	2.2	16	100	200	600	1.8, 2.5, 2.8, 3.0, 3.3, 5	1.3 to 9	1		✓								EN	3.3 µF, C	Fast transient response		0.36																
TPS7A49xx	3	36	150	333	65	—	1.2 to 33	1.5				✓						EN, SS	2.2 µF, C	Ultra-wide PSRR, low noise		1.10																
TPS717xx	2.5	6.5	150	170	50	0.9, 1.0, 1.1, 1.2, 1.3, 1.5, 1.8, 1.85, 1.9, 2.1, 2.5, 2.6, 2.7, 2.8, 2.85, 2.9, 3.0, 3.3, 4.5, 5.0, EEPROM ⁴	0.9 to 6.2	1.5	✓				✓					EN, BP	1 µF, C	Ultra-high PSRR		0.36																
TPS731xx	1.7	5.5	150	30	400	1.5, 1.8, 2.5, 3.0, 3.3, 5.0, EEPROM ⁴	1.2 to 5.5	1		✓								EN, BP	No Cap	Reverse leakage protection	H	0.45																
TPS780xx	2.2	5.5	150	130	0.5	3.3/2.2, 2.3/3.0, 2.7/2.0, 3.0/2.5, EEPROM ⁴	1.22 to 5.25	3		✓			✓					EN, VSET	1.0 µF, C	Dual-level output, low I _q		0.50																
TPS782xx	2.2	5.5	150	130	0.5	2.3, 2.5, 2.7, 2.8, 3.0, 3.3, EEPROM ⁴	—	3		✓			✓					EN	1 µF, C	MSP430 lowest I _q , low price	A	0.25																
TPS783xx	2.2	5.5	150	130	0.5	3.0, EEPROM ⁴	—	3		✓								EN	1 µF, C	TPS782 without active pulldown		0.25																
TLV700xx	2	5.5	150	125	31	1.2, 1.5, 1.8, 2.8, 3.0, 3.3	—	2	✓	✓			✓					EN	1 µF, C	Low price, high performance	A	0.18																
LP2985	2.2	16	150	280	850	1.8, 2.5, 2.8, 3.3, 5.0, 10	—	1	✓	✓								EN	3.3 µF, C	Fast transient response		0.36																
TPS730xx	2.7	5.5	200	120	180	1.8, 2.5, 2.8, 2.85, 3.0, 3.3, 4.7	1.22 to 5.5	2		✓								EN, BP	2.2 µF, C	Low price		0.23																
TPS728xx	2.7	6.5	200	230	45	3.15/1.85, 1.5/1.2, EEPROM ⁴	—	3	✓				✓					EN, VSET	1.0 µF, C	Dual-level output (H/L)		0.39																
TLV707xx	2.0	5.5	200	280	35	1.8	—	2					✓					EN	1 µF, C	1x1-mm SON4 package		0.25																
TLV707xxP	2.0	5.5	200	280	35	1.8, 2.8	—	2					✓					EN	1 µF, C	TLV707 with active pulldown		0.25																
TLV705xx	2.0	5.5	200	175	31	1.8	—	2	✓									EN	1 µF, C	0.8 x 0.8-mm WCSP		0.30																
TPS799xx	2.7	6.5	200	100	40	1.2, 1.3, 1.5, 1.8, 1.85, 1.9, 1.95, 2.0, 2.1, 2.5, 2.6, 2.7, 2.75, 2.8, 2.85, 3.0, 3.15, 3.2, 3.3, 4.2, 4.5, EEPROM ⁴	1.2 to 5.5	2	✓	✓			✓					EN, BP	2.2 µF, C	Low power vs. TPS793xx	A	0.30																
TPS727xx	2	5.5	250	130	7.9	1.5, 1.8, 1.85, 2.5, 2.8, 2.85, 3.0, 3.3, EEPROM ⁴	—	2	✓				✓					EN	1 µF, C	Low I _q , high performance		0.48																
TPS734xx	2.7	6.5	250	113	44	1.8, 3.0, 3.3, EEPROM ⁴	1.2 to 6.5	2		✓			✓					EN	2.0 µF, C	High PSRR, low noise		0.35																
TPS732xx	1.7	5.5	250	40	400	1.3, 1.5, 1.6, 1.8, 1.9, 2.5, 3.0, 3.3, 5.0, EEPROM ⁴	1.2 to 5.5	1		✓			✓	✓				EN, BP	No Cap	Reverse leakage protection	H, A	0.65																
TPS773xx	2.7	10	250	125	90	1.5, 1.6, 1.8, 2.7, 2.8, 3.3, 5.0	1.5 to 5.5	2				✓						/EN, SVS	10 µF, T	Low noise		0.70																
TLV702xx	2.0	5.5	300	430	31	1.8, 2.5, 2.8, 3.0, 3.1, 3.3, EEPROM ⁴	—	2		✓								EN	1 µF, C	Low price, high performance		0.20																
TLV702xxP	2.0	5.5	300	430	31	2.8, EEPROM ⁴	—	2		✓								EN	1 µF, C	TLV702 with active pulldown		0.20																
TLV712xx	2.0	5.5	300	260	31	0.9, EEPROM ⁴	—	2		✓								EN	1 µF, C	V _{OUT} < 1.2 V, low price, high performance		0.25																
TPS7A60xx	4.0	45	300	500	25	3.3, 5.0	—	2										EN, RST	1 µF, C	High V _{IN} with reset output	A	1.15																
TPS720xx	1.1	4.5	350	100	29	1.0, 1.05, 1.2, 1.3, 1.5, 1.7, 1.8, EEPROM ⁴	—	2	✓									EN	2.2 µF, C	High PSRR		0.48																

¹xx represents the voltage option. For example, 33 represents the 3.3-V option. The adjustable output voltage option is represented by 01.

²BP = bypass pin for noise reduction capacitor, EN = active high enable, /EN = active low enable, PG = Power Good, SS = soft-start pin, SVS = supply voltage supervisor, TR = tracking, VSET = dual-level output voltage select pin (H/L).

³C = ceramic, T = tantalum, No Cap = capacitor-free LDO.

⁴EEPROM programmable at the factory, allowing production of custom fixed voltages. Minimum quantities apply. Please contact TI.

[†]Devices qualified for HiRel (H) or Automotive (A) applications are available. Certain voltage options are not available. Different pricing may apply.

New devices are listed in bold red.

*Suggested resale price in U.S. dollars in quantities of 1,000.

Point-of-Load Solutions

Linear and Low Dropout (LDO) Regulators

Low Dropout (LDO) Regulators Selection Guide (Continued)

Device ¹	Min V _{IN}	Max V _{IN}	I _O (mA)	V _{DO} at I _O (mV)	I _q (μA)	Output Options		Accuracy (%)	Packages(s)										Features ²	C ₀ ³	Comments	HiRel (H) or Automotive (A) [†]	Price*																			
						Fixed Voltage (V)	Adj. (V)		WGSOP	SC70	SOT23	SOT189	MSOP	QFN	S08	SOT23	PWP	TO220						PW	TO263	TO252																
Positive Voltage, Single Output Devices (Continued)																																										
TPS736xx	1.7	5.5	400	75	300	1.25, 1.5, 1.6, 1.8, 1.9, 2.5, 3.0, 3.2, 3.3, 4.3, EEPROM ⁴	1.2 to 5.5	1			✓			✓						EN, BP	No Cap	Reverse leakage protection	H	0.85																		
TPS747xx	0.8	5.5	500	50	1 mA	EEPROM ⁴	0.8 to 3.6	2						✓						EN, SS, PG	2.2 μF, C	Low V _{OUT} , low dropout	A	0.75																		
TPS735xx	2.7	6.5	500	113	46	1.2, 1.5, 2.5, 3.3, 3.4, EEPROM ⁴	1.2 to 6.5	2						✓						EN	2.0 μF, C	High PSRR, low noise		0.75																		
TPS775xx	2.7	10	500	169	87	1.5, 1.6, 1.8, 2.5, 3.3	1.5 to 5.5	2						✓						/EN, SVS	10 μF, T	Fast transient response	H, A	0.95																		
TPS776xx	2.7	10	500	169	87	1.5, 1.8, 2.5, 2.8, 3.3	1.2 to 5.5	2						✓						/EN, PG	10 μF, T	Fast transient response	H, A	0.70																		
TPS777xx	2.7	10	750	260	85	1.5, 1.8, 2.5, 3.3	1.5 to 5.5	2						✓						/EN, SVS	10 μF, T	Fast transient response		1.05																		
TLV1117-xx	2.7	15	800	1200	5	1.5, 1.8, 2.5, 3.3, 5.0	1.24 to 13.5	1						✓								10 μF, T	Low price		0.16																	
TPS7A80xx	2.2	6.5	1000	500	60	EEPROM ⁴	0.8 to 6.0							✓						EN	4.7 μF, C	Ultra-wide PSRR, low noise		1.00																		
TLV1117LV	2.0	5.5	1000	900	100	1.2, 1.8, 2.5, 3.3, 5.0	—	1						✓								1 μF, C	High PSRR, low price		0.27																	
TPS737xx	2.2	5.5	1000	200	300	1.8, 1.9, 2.5, 3.0, 3.3, 3.4, EEPROM ⁴	1.2 to 5.5	3						✓						EN	1 μF, C	Low price	A	0.60																		
TPS725xx	1.8	6	1000	170	75	1.5, 1.6, 1.8, 2.5	1.2 to 5.5	2						✓						EN, SVS	No Cap	Low noise; SVS delay 50 ms		1.10																		
TPS767xx	2.7	10	1000	230	85	1.5, 1.8, 2.5, 2.7, 2.8, 3.0, 3.3, 5.0	1.5 to 5.5	2						✓						/EN, SVS	10 μF, T	Fast transient response	H, A	1.10																		
TPS768xx	2.7	10	1000	230	80	1.5, 1.8, 2.5, 2.7, 2.8, 3.0, 3.3, 5.0	1.2 to 5.5	2						✓						/EN, PG	10 μF, T	Fast transient response	H, A	0.90																		
TPS742xx	0.8	5.5	1500	55	2 mA	EEPROM ⁴	0.8 to 3.3	1						✓						EN, SS, PG	No Cap	Low V _{OUT} , high accuracy		1.70																		
TPS743xx	0.8	5.5	1500	55	2 mA	EEPROM ⁴	0.8 to 3.3	1						✓						EN, TR, PG	No Cap	Low V _{OUT} , high accuracy		2.00																		
TPS748xx	0.8	5.5	1500	60	1 mA	—	0.8 to 3.3	2						✓						EN, SS, PG	2.2 μF, C	Low V _{OUT}		1.00																		
TPS786xx	2.7	5.5	1500	390	310	1.8, 2.5, 2.8, 3.0, 3.3	1.2 to 5.5	2						✓						EN, BP	1 μF, C	RF low noise, high PSRR		1.35																		
TPS7A45	2.2	20	1500	300	1 mA	1.5, 1.8, 2.5, 3.3	1.21 to 20	1						✓						EN	10 μF, C	Wide V _{IN} , high performance		1.45																		
TL1963A	2.2	20	1500	340	1 mA	1.5, 1.8, 2.5, 3.3	1.21 to 21	1						✓						EN	10 μF, C	Wide V _{IN} , high performance	A	1.35																		
TPS752xx	2.7	5	2000	210	75	1.5, 1.8, 2.5, 3.3	1.5 to 5.0	2						✓						/EN, SVS	47 μF, T	Fast transient response	H, A	1.80																		
TPS744xx	0.8	5.5	3000	115	2 mA	EEPROM ⁴	0.8 to 3.3	1						✓						EN, SS, PG	No Cap	Low V _{OUT} , high accuracy	H	2.95																		
TPS749xx	0.8	5.5	3000	120	1 mA	—	0.8 to 3.3	2						✓						EN, SS, PG	2.2 μF, C	Low V _{OUT}		2.00																		
TPS51100	4.75	5.25	3000	1250	3	1/2 VDDQSNS	—	1.6						✓						EN	20 μF, C	DDR/DDR2 VH power		0.80																		
TPS758xx	2.8	5.5	3000	150	110	1.5, 1.8, 2.5, 3.3	1.2 to 5.0	3						✓						EN	47 μF, T	Fast transient response		2.70																		
UC385-x	1.7	7.5	5000	350	8 mA	1.5, 2.1, 2.5	1.2 to 6.0	1						✓						—	100 μF, T	Fast LDO with reverse leak		3.15																		
TPS756xx	2.8	5.5	5000	250	110	1.5, 1.8, 2.5, 3.3	1.2 to 5.0	3						✓						EN	47 μF, T	Fast transient response		3.00																		
TPS759xx	2.8	5.5	7500	400	110	1.5, 1.8, 2.5, 3.3	1.2 to 5.0	3						✓						/EN, PG	47 μF, T	Fast transient response		3.20																		
Negative Voltage, Single Output Devices																																										
TPS7A30xx	-36	-3	200	216	55	—	-1.2 to -33	1.5						✓						EN, SS	2.2 μF	Ultra-wide PSRR, low noise		1.50																		
TPS723xx	-10	-2.7	200	280	130	-2.5	-1.2 to -9.0	2			✓									EN, BP	2.2 μF, C	Low noise, high PSRR		1.05																		
UCC384-x	-15	-3.5	500	150	200	-12.0, -5.0	-1.25 to -15	3						✓						/EN	4.7 μF, T	Duty cycle short		1.86																		

¹xx represents the voltage option. For example, 33 represents the 3.3-V option. The adjustable output voltage option is represented by 01.

²BP = bypass pin for noise reduction capacitor, EN = active high enable, /EN = active low enable, PG = Power Good, SS = soft-start pin, SVS = supply voltage supervisor, TR = tracking, VSET = dual-level output voltage select pin (H/L).

³C = ceramic, T = tantalum, No Cap = capacitor-free LDO.

⁴EEPROM programmable at the factory, allowing production of custom fixed voltages. Minimum quantities apply. Please contact TI.

[†]Devices qualified for HiRel (H) or Automotive (A) applications are available. Certain voltage options are not available. Different pricing may apply.

New devices are listed in bold red.
Preview devices are listed in bold blue.

*Suggested resale price in U.S. dollars in quantities of 1,000.

Dual Channel LDO Selection Guide

Device	I _{O1} (mA)	I _{O2} (mA)	V _{DO1} at I _{O1} (mV)	V _{DO2} at I _{O2} (mV)	I _q (μA)	Output Options		Accuracy (%)	Package(s)	Features					C ₀ ¹	Comments	Price*				
						Fixed Voltage (V)	Adj.			V _O		Enable	PG	SVS				Seq	Low Noise	V _{IN}	
									(min)	(max)	(min)				(max)						
TPS51103	100	100	400	400	35	3.3/5.0	—	2	QFN	—	—	EN					4.5	28	100 μF, C	250-kHz clock output for charge pump, always-on 3.3-V, 5-mA LDO output for RTC	1.00

¹C = ceramic.

*Suggested resale price in U.S. dollars in quantities of 1,000.

Point-of-Load Solutions

Linear and Low Dropout (LDO) Regulators

Dual Output LDOs Selection Guide

Device	I _{O1} (mA)	I _{O2} (mA)	V _{DO1} at I _{O1} (mV)	V _{DO2} at I _{O2} (mV)	I _Q (μA)	Output Options		Accuracy (%)	Package(s)	V _O		Features						Comments	HiRel (H) or Automotive (A) [†]	Price*			
						Fixed Voltage (V)				Adj.	(min)	(max)	Enable	PG	SVS	Seq	Low Noise				V _{IN}		C _O ¹
						(min)	(max)			(V)	(V)	(min)									(max)		
TLV710	200	200	175	175	70	1.8/2.8		—	2	SON 6	1.2	4.8	EN				✓	2.0	5.5	1.0 μF, C	Value-priced dual LDO		0.33
TLV711	200	200	175	175	70	3.3/3.3		—	2	SON 6	1.2	4.8	EN				✓	2.0	5.5	1.0 μF, C	TLV710xx w/ active output pulldown		0.33
TPS719xx	200	200	230	230	100	1.3/2.8, 1.8/1.2, 1.8/1.3, 2.1/2.2, 2.6/1.5, 2.8/2.8, 2.85/2.85, 3.3/2.8, 3.3/3.3, 3.6/3.15 See Note 2		—	3	QFN/WCSP	0.9	3.6	EN				✓	2.5	6.5	1.0 μF	TPS718xx w/ active output pulldown		0.55
TPS718xx	200	200	230	230	100	1.2/3.3, 1.8/2.7, 1.8/3.3, 2.5/1.2, 2.8/2.8, 2.8/3.0 See Note 2		—	3	QFN/WCSP	0.9	3.6	EN				✓	2.5	6.5	1.0 μF	High PSRR, low V _{OUT}		0.55
TPS712xx	250	250	145	145	400	1.8/2.85, 1.8/Adj., 2.8/2.8, 2.8/Adj., 2.85/2.85		✓	2	QFN	1.2	5.5	EN				✓	2.7	5.5	2.2 μF, C		H	0.80
TPS713xx	250	250	145	145	400	3.3/Adj., 1.8/Adj.		✓	2	QFN	1.2	5.5	EN		✓	✓	✓	2.7	5.5	2.2 μF, C	Integrated SVS		0.90
TPS707xx	250	150	83	125	187	See Web		✓	2	PWP	1.2	5	EN	✓	✓	✓	✓	2.7	5.5	10 μF, T	See TPS708xx ³	H	1.20
TPS701xx	500	250	170	220	187	See Web		✓	2	PWP	1.2	5	EN	✓	✓	✓	✓	2.7	5.5	10 μF, T	See TPS702xx ³	A	1.50
TPS767D3xx	1000	1000	350	350	85	3.3/2.5, 3.3/1.8		✓	2	PWP	1.5	5.5	EN		✓			2.7	10	10 μF, T	Dual-output fast LDO with integrated SVS	H, A	2.00
TPS703xx	1000	2000	160	190	185	See Web		✓	2	PWP	1.2	5.5	EN	✓	✓	✓	✓	2.7	5.5	22 μF, T	See TPS704xx ³	H	2.35
TPPM0110/1	1500	300	1000	2500	1000	3.3/1.8, 3.3/1.5		—	2	—	1.8	3.3	—					4.7	5.3	100 μF, T	See TPPM0111 for 3.3-V/1.5-V output		1.60

¹C = ceramic, T = tantalum.

New devices are listed in bold red.

²EEPROM programmable at the factory, allowing production of custom fixed voltages. Minimum quantities apply. Please contact TI.

³For independent enables instead of integrated sequencing.

[†]Devices qualified for HiRel (H) or Automotive (A) applications are available. Certain voltage options are not available. Different pricing may apply.

*Suggested resale price in U.S. dollars in quantities of 1,000.

Standard Linear Voltage Regulators Selection Guide

Device	V _{IN}		I _{OUT} (max) (mA)	V _{OUT} (nom) (V)	HiRel (H) or Automotive (A) [†]	Price*
	MIN (V)	MAX (V)				
LM237, LM337	-4.2	-40	1500	Adj. (-1.2 to -37)		0.29
LM317, LM317M	4.2	40	1500, 500	Adj. (1.2 to 37)		0.27
MC79Lxx/A	-7	-20	100	-5, -12, -15		0.13
TL317/L/M	4.2	40	1500/100/500	Adj. (1.2 to 35)		0.14
TL780-xx	7	25	1500	5, 12, 15		0.32
TL783	21.5	125	700	Adj. (1.25 to 125)		1.15
UA723	5	40	150	Adj. (2 to 37)		0.29
UA78Lxx/A	4.75	20	100	2.6, 5, 6.2, 8, 9, 10, 12, 15		0.11
UA78Mxx	7	25	500	3.3, 5, 6, 8, 9, 12	A	0.25
UA78xx	7	25	1500	5, 8, 10, 12, 15, 24		0.23
UA79xx	-7	-25	1500	-5, -8, -12, -15	H	0.25
UA79Mxx	-10.5	-25	500	-5, -8		0.25

[†]Devices qualified for HiRel (H) or Automotive (A) applications are available. Certain voltage options are not available. Different pricing may apply.

*Suggested resale price in U.S. dollars in quantities of 1,000.

Point-of-Load Solutions

→ Multi-Output Power Management Units

PMU with Linear Charger and WLED Backlighting

TPS65072

NEW

Get samples and datasheets at: www.ti.com/sc/device/TPS65072

The TPS65072 is a flexible PMU integrating a linear battery charger with dynamic power-path management (DPPM). It has three step-down converters, two general-purpose LDOs, a WLED boost converter (up to 2x 7 LEDs), and internal and external sequencing. It is available for different processors in a small 6x6-mm QFN package.

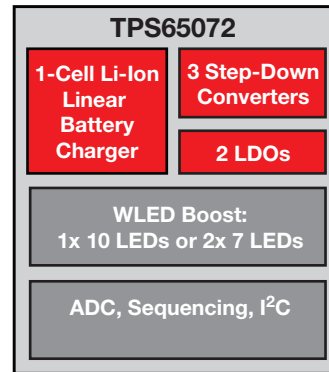

Flexible PMU for Cortex[®]-8 and ARM11[™]

TPS65910

NEW

Get samples, datasheets, evaluation modules and app reports at: www.ti.com/sc/device/TPS65910

The TPS65910 is a general-purpose PMU for applications that require multiple power rails, like low-power processors (OMAP[™], Sitara[™], Samsung, Freescale, etc). It is available in a 6x6-mm QFN.

- High flexibility: Targeting popular ARM[®]-based processors
- Reference designs available: Fast time-to-market
- Class-3 SmartReflex[™] interface for optimum power savings
- Advanced power-sleep management: All LDO DC/DC-state configurable with one ball; <20 μ A in OFF mode with RTC ON
- Cost-optimized solution

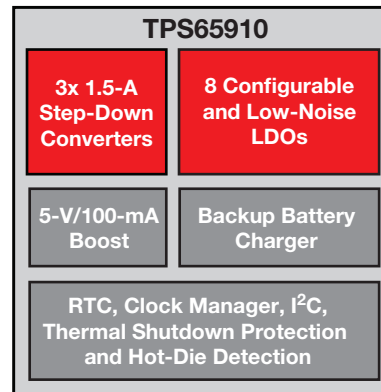

PMU with 3x Buck Converter with Integrated FETs and up to 18 V_{IN}

TPS65250/1

Get samples and datasheets at: www.ti.com/sc/device/TPS65250

The TPS65250/1 are general-purpose PMUs integrating 3x buck converters with integrated FETs (2 A, 2 A, 3 A) and a wide V_{IN} from 4.5 to 18 V. In case of power shutdown, the “Dying Gasp” function (TPS65250 only) allows critical data to be saved first. The devices are available in 6 x 6-mm QFN packages.

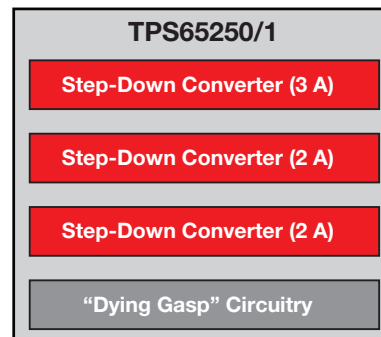

Point-of-Load Solutions

Multi-Output Power Management Units

Selection Guide

Device	V _{IN} (V)	No. of Regulator Outputs	Charger	Audio Codec	USB 2.0 OTG Transceiver	WLED Boost	DC/DC Step-Down Converter	DC/DC Step-Down Controller	LDO	Communication Interface	Description	Package	Automotive Qualified (A) [†]	Price*
TPS65200	2.5 to 6.5	0	Switch	—	—	✓	—	—	—	I ² C	With current shunt monitor, also QFN	WCSP-36	—	2.45
TPS65831	3.0 to 6.0	0	Switch	—	—	✓	—	—	—	I ² C	SW charger with Flash, WLED and RGB LEDs	WCSP-49	—	3.45
TPS80010	1.8 to 3.6	2	—	—	—	—	1	—	1	—	Ideal for 2-cell Alkaline	QFN-32	—	1.55
TPS65720/1	4.3 to 28.0	2	Linear	—	—	—	1	—	1	I ² C	Smallest 1-Li-Ion applications, also QFN	WCSP-25	—	1.65
TPS65252	4.5 to 16.0	2	—	—	—	—	2	—	—	—	USB switch with adjustable current limit	QFN-28	—	2.95
TPS65000/6	1.8 to 6.0	3	—	—	—	—	1	—	2	—	General purpose. TPS65001 with supervisor	QFN-16	—	1.40
TPS75003	2.2 to 6.5	3	—	—	—	—	—	2	1	—	PMU for FPGA, DPS and ASIC	QFN-20	—	1.90
TPS657051/2	3.3 to 6.0	3	—	—	—	—	2	—	1	—	General purpose	WCSP-16	—	1.20
TPS65210	1.8 to 5.5	3	—	—	—	✓	2	—	—	—	With buck/boost	QFN-28	—	TBD
TPS65250/1	4.5 to 18.0	3	—	—	—	—	3	—	—	—	With “dying gasp” function	QFN-40	—	3.05
TPS65257/8	4.5 to 16	3	—	—	—	—	3	—	—	—	With 1/2 USB switches	QFN-40	—	3.25
TPS65232	10.8 to 22.0	3	—	—	—	—	2	1	—	I ² C	Wide input voltage range, also QFN	HTSSOP-48	—	2.70
TPS65230/1	10.8 to 22.0	3	—	—	—	—	2	1	—	I ² C	With two 0.5-A or 1-A USB switches	HTSSOP-48	—	2.80
TPS65708	3.5 to 6.0	4	—	—	—	—	2	—	2	—	With 7.5-mA PWM dimmable current sink	WCSP-16	—	1.65
TPS65010/1/2/3/4	4.5 to 5.5	4	Linear	—	—	—	2	—	2	I ² C	General purpose PMU with charger	QFN-48	—	2.55
TPS65220	2.7 to 9.9	5	Linear	✓	—	✓	2	—	3	I ² C	Integrated mono class-D amplifier	QFN-56	—	TBD
TPS65053/8	2.5 to 6.0	5	—	—	—	—	2	—	3	—	Low-cost 5-channel PMU	QFN-24	—	1.85
TPS65070/2/3	2.8 to 6.3	5	Linear	—	—	✓	3	—	2	I ² C	With and without touchscreen controller	QFN-48	—	3.60
TPS65020/1/2	2.5 to 6.0	6	—	—	—	—	3	—	3	I ² C	PMU with high-current DC/DC	QFN-40	—	3.05
TPS65023x	2.5 to 6.0	6	—	—	—	—	3	—	3	I ² C	Flexible 6x channel PMU, also WCSP package	QFN-40	A	3.30
TPS650240/1/2/3/4/5	2.5 to 6.0	6	—	—	—	—	3	—	3	Logic H/L	PMU with logic high/low voltage scaling	QFN-32	A	2.95
TPS650250	2.5 to 6.0	6	—	—	—	—	3	—	3	—	Flexible PMU with all V _{OUT} externally adjustable	QFN-32	A	2.95
TPS65050/1/2/4/6	2.5 to 6.0	6	—	—	—	—	2	—	4	Logic H/L	General purpose PMU	QFN-32	—	1.85
TPS65215	2.7 to 6.5	7	Linear	—	—	✓	3	—	4	—	WLED with 38-V output for up to 2 x 10 LEDs in series	QFN-48	—	TBD
TPS65921	2.7 to 4.5	7	—	—	✓	—	3	—	4	2x I ² C	Optimized for OMAP35x processors	BGA-139	—	3.60
TPS65930	2.7 to 4.5	7	—	✓	✓	—	3	—	4	2x I ² C	Optimized for OMAP35x processors	BGA-139	—	3.95
TPS65951	2.7 to 4.5	12	—	✓	✓	—	3	—	9	2x I ² C	Optimized for OMAP35x processors, 0.8mm pitch	BGA-169	—	4.50
TPS65910x	2.7 to 5.5	13	—	—	—	—	3	—	9	2x I ² C	Very flexible PMU, with 5-V boost	QFN-48	—	3.45
TPS65911x	2.7 to 5.5	13	—	—	—	—	3	1	9	2x I ² C	Flexible PMU with DC/DC controller up to 10 A	BGA-98	—	4.45
TPS65950	2.7 to 4.5	13	Linear	✓	✓	—	3	—	10	2x I ² C	Optimized for OMAP35x processors	BGA-209	—	4.50
TPS658620/1/2/3/4	4.3 to 6.5	14	Linear	—	—	✓	3	—	11	I ² C	Optimized for Nvidia processors	BGA-121	A	5.95
TWL6030/40	2.3 to 5.5	18	Switch	✓	—	—	7	—	11	2x I ² C	Dual ICs: Audio and power, optimized for OMAP4	FBGA + PBGA	—	6.35

[†] Devices qualified for Automotive (A) applications are available. Certain voltage options are not available. Different pricing may apply.

*Suggested resale price in U.S. dollars in quantities of 1,000.

New devices are listed in **bold red**.
Preview devices are listed in **bold blue**.

→ Multi-Output Power Management Units

Embedded Processors Supported by TI Power-Management Units (PMUs)

Processor	Part Number	PMU	Processor	Part Number	PMU
TI	DM335, DM355, DM365	TPS65053, TPS65070	Freescall	IMX25	TPS65051/2
TI	DM368	TPS650532, TPS65023	Freescall	IMX27	TPS65053, TPS659107
TI	DM37x	TPS6595x/30/2x/10, TPS65023, TPS65073	Freescall	IMX31	TPS650240, TPS659106
TI	DM37x at 1 GHz	TPS65950A3/x21B1/x10, TPS65023, TPS65073	Freescall	IMX35	TPS650250, TPS659107
TI	DM643x, DM644x	TPS65023, TPS659105	Freescall	IMX37, IMX51	TPS659109
TI	DM812x	TPS659113	Freescall	IMX508	TPS659108
TI	DM816x	TPS65232, TPS659112	Freescall	IMX53	2Q11 – Check the Web
TI	AM17x, AM18x	TPS65910, TPS650061, TPS65070	Marvell	Armada MMP2	Please contact TI
TI	AM35x	TPS65910, TPS650732, TPS65023	Nvidia	APX2500/2600	TPS658600
TI	AM37x	TPS6595x/30/2x/10, TPS65023, TPS65073	Nvidia	Tegra 600/650	TPS658610
TI	AM37x at 1 GHz	TPS65950A3/x21B1/x10, TPS65023, TPS65073	Nvidia	T20	TPS658621/3/4
TI	AM387x	TPS659113, TPS65232	Nvidia	AP20	TPS658622
TI	AM389x	TPS65232, TPS659112	Samsung	S3C2410/2/3	TPS65051/2
TI	OMAP3503/15/25/30	TPS6595x/30/2x/10, TPS65073x, TPS65023	Samsung	S3C2416	TPS650250, TPS650240
TI	OMAP3611/21/30	TPS6595x/30/2x/10, TPS65023	Samsung	S3C6410	TPS650240, TPS65910
TI	OMAP4	TWL6030 + TWL6040	Samsung	S5PV210, S5PC110	TPS659101
TI	OMAP-L137	TPS65910, TPS65023	Samsung	S5PC100	TPS659103
TI	OMAP-L138	TPS65910, TPS65070, TPS65023	Samsung	S5P6440	TPS659104
TI	C2834x	TPS65000, TPS650061	RMI	AU1200/1300	TPS65021
TI	C6742/6/8	TPS65910, TPS65070, TPS65023	Sirf	ATLAS 4	TPS65072
TI	C6745/7	TPS65910, TPS65023	STM	STA2065	TPS65215
TI	C6A816x	TPS65232, TPS659112	Rockchip	RK29xx	TPS659102

Reference designs for these TI processor families are available online. Bookmark these pages and check often to find new designs for the latest DSP and microprocessor generations. PMU solutions with and without battery charger:

www.ti.com/pmu

TI power-management reference designs:

www.ti.com/processorpower

Point-of-Load Solutions

→ DC/DC Controllers (External Switch)

DC/DC Controller Supports 3.3/5/12-V Rails

TPS40303/4/5

NEW

Get samples, datasheets and evaluation modules at: www.ti.com/sc/device/TPS40303, www.ti.com/sc/device/TPS40304 or www.ti.com/sc/device/TPS40305

The TPS40303/4/5 buck controllers operate at input voltages ranging from 3 to 20 V. Voltage-mode control architecture with input feed-forward compensation responds instantaneously to input-voltage changes. The switching frequency is fixed at 300 kHz, 600 kHz and 1.2 MHz, respectively. The frequency spread spectrum feature adds dither to the switching frequency, significantly reducing EMI peak noises and facilitating compliance to EMI standards. Strong 6.5-V gate drivers at 2 A offer high efficiency at currents of up to 25 A. Soft start, overcurrent protection (OCP) levels and loop compensation are user-programmable. These programmable features offer design flexibility and optimized component selection for the end user. The TPS40303/4/5 family is available in the 10-pin SON (DRC) package.

Key Features

- Input-voltage range from 3 V to 20 V
- 300 kHz (TPS40303), 600 kHz (TPS40304) and 1.2 MHz (TPS40305) switching frequencies
- High- and low-side FET $r_{DS(on)}$ current sensing
- Programmable thermally compensated OCP levels
- Programmable soft start
- 600 mV, 1% reference voltage

- Voltage feed-forward compensation
- Supports pre-biased output
- Frequency spread spectrum
- Thermal shutdown protection at 145°C
- 10-pin 3x3-mm SON package with ground connection to thermal pad

Applications

- POL modules
- Printers
- Digital TV
- Telecom

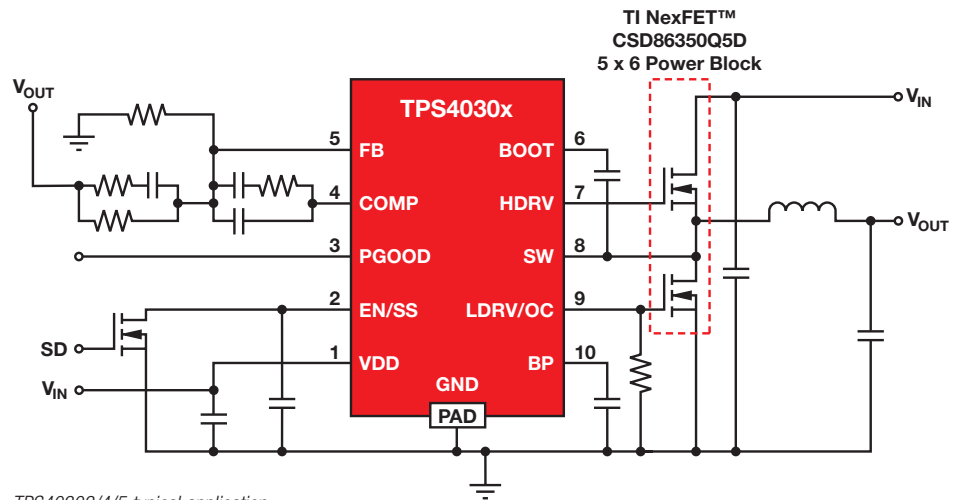

TPS40303/4/5 typical application.

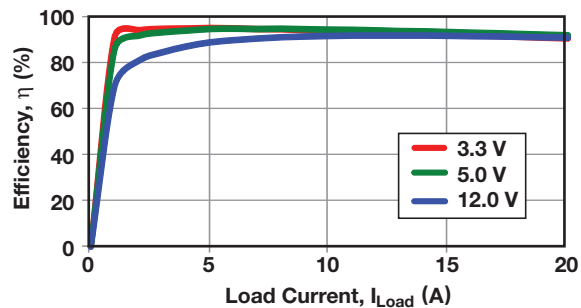

TPS40303/4/5 efficiency >90% with loads of 1 to 20 A.

Point-of-Load Solutions

→ DC/DC Controllers (External Switch)

Selection Guide

All parts have soft start, short-circuit protection, and undervoltage lockout functions.

Device	Mode of Control ¹	V _{IN} (min/max) (V)	V _O (min/max) (V)	Driver Current (A)	Output Current (A) ²	Frequency (kHz)	V _{REF} Tol (%)	Internal Bootstrap	Package(s)	Pwr Good	Source & Sink ³	Pre-biased Operation	Ext Synchron Pin	Predictive Gate Drive™	DDR ⁴	Remote Sense	HiRel (H) or Automotive (A) [†]	Price*
General-Purpose DC/DC Voltage Mode Buck Controllers (All devices in this family except the TPS40200 are synchronous.)																		
TPS40000/2	V	2.25/5.5	0.7/4	1	15	300/600	1	Yes	10 MSOP	No	No	Yes	No	Yes	No	No		0.99
TPS40007/9	V	2.25/5.5	0.7/4	1	15	300/600	1	Yes	10 MSOP	No	Yes ¹⁰	Yes	No	Yes	No	No		1.20
TPS40020/21	V	2.25/5.5	0.7/4	2	25	Adj. to 1000	1	Yes ⁹	16 HTSSOP	Yes	21 ¹⁰	20	Yes	Yes	No	No		1.45
TPS40040	V	2.25/5.5	0.6/4.95	1	15	300	1	Yes	8 SON	No	Yes ¹⁰	Yes	No	No	No	No		0.90
TPS40041	V	2.25/5.5	0.6/4.88	1	15	600	1	Yes	8 SON	No	Yes ¹⁰	Yes	No	No	No	No		0.90
TPS40042	V	3/5.5	0.7/4.95	1.2	15	600	Ext	Yes	10 SON	No	Yes ¹⁰	Yes	No	No	Yes	No		0.90
TPS40054/55/57	VFF	8/40	0.7/35	1	20	Adj. to 1000	1	Yes	16 PwrPAD	No	55, 57 ¹⁰	57	Yes	No	No	No	H	1.65
TPS40056	V	10/40	0.7/35	1	20	Adj. to 1000	Ext	Yes	16 PwrPAD	No	Yes	No	Yes	No	Yes	No		1.65
TPS40170	VFF	8/60	0.6/55	1.2	15	Adj. to 600	1	Yes	20 QFN	Yes	Yes ¹⁰	Yes	Yes	No	No	No		2.40
TPS40075	VFF	4.5/28	0.7/23	1	20	Adj. to 1000	1	Yes	20 QFN	Yes	Yes ¹⁰	Yes	Yes	Yes	No	Yes		1.80
TPS40077	VFF	4.5/28	0.7/23	1	20	Adj. to 1000	1	Yes	16 PwrPAD	Yes	Yes ¹⁰	Yes	No	Yes	No	No		1.60
TPS40100 ⁶	C	4.5/18	0.7/5.5	1.3	20	600	1	No	24 QFN	Yes	Yes ¹⁰	Yes	Yes	No	No	Yes		1.95
TPS40101 ⁶	V	4.5/18	0.7/5.5	1.3	20	1000	1	No	24 QFN	Yes	Yes ¹⁰	Yes	Yes	No	No	Yes		1.95
TPS40190	V	4.5/15	0.59/12.75	1.2	20	300	1	Yes	10 SON	No	Yes ¹⁰	Yes	No	No	No	No		1.00
TPS40192/3	V	4.5/18	0.59/14.4	1.2	15/20	600/300	0.5	Yes	10 SON	Yes	Yes ¹⁰	Yes	No	No	No	No		1.05
TPS40195 ⁷	V	4.5/20	0.59/17	1.2	20	Adj. to 600	0.5	Yes	16 TSSOP, 16 QFN	Yes	Yes ¹⁰	Yes	Yes ⁷	No	No	No		1.50
TPS40303/4/5	V	3/20	0.6/18	2	25	300/600/1200	1	Yes	10 SON	Yes	Yes ¹⁰	Yes	No	No	No	No		1.50
TPS40200 ⁸	VFF	4.5/52	0.7/46	0.2	3	Adj. to 500	1	No ⁵	8 SOIC	No	No	No	Yes	No	No	No	H, A	0.75
TPS53114	D-CAP2 Mode™	4.5/26	0.76/5.5	0.7	12	350/700	1	Yes	16 TSSOP, 16 HTSSOP	No	Yes	Yes	No	No	No	No		1.35
TPS53124 (dual output)	D-CAP Mode™	4.5/26	0.76/5.5	0.7	12	380	1	Yes	24 QFN, 28 TSSOP	No	Yes	Yes	No	No	No	No		1.95
TPS53125/26/27 (dual output)	D-CAP2 Mode	4.5/26	0.76/5.5	0.7	12	350/700		Yes	24 QFN, 24 TSSOP	No	Yes	Yes	No	No	No	No		2.35

¹V = voltage-mode control, VFF = voltage mode with voltage feed-forward compensation, and C = Current-feedback control.

²Current levels of this magnitude can be supported with commonly available commercial FETs.

³The controller of choice for most applications will be the source/sink version, which has two-quadrant operation and will source or sink output current.

⁴DDR = Supports DDR memory.

⁵Drives high-side P-FET.

⁶Provides advanced startup sequencing and output voltage margining.

⁷Bidirectional 180° out-of-phase synchronization.

⁸Nonsynchronous, drives P-FETs.

⁹Integrated voltage-doubler charge pump for higher drive voltage.

¹⁰During soft start: source only.

[†]Devices qualified for HiRel (H) or Automotive (A) applications are available. Certain voltage options are not available. Different pricing may apply.

*Suggested resale price in U.S. dollars in quantities of 1,000.

New devices are listed in bold red.

Point-of-Load Solutions

→ DC/DC Controllers (External Switch)

Selection Guide (Continued)

All parts have soft start, short-circuit protection, and undervoltage lockout functions.

Device	Switched Outputs	Phases	V _{IN} (min/max) (V)	V _O (min/max) (V)	Driver Current (A)	Output Current (A) ¹	Frequency (kHz)	V _{REF} Tol (%)	Package(s)	Pwr Good	Overshoot Protection	Source & Sink ²	Pre-biased Operation	Ext Synch Pin	Remote Sense	Price*
Multiphase Synchronous DC/DC Buck Controllers																
TPS40090 ³	1	2 to 4	4.5/15	0.7/3.3	Var	30/phase	Adj. to 1000	1	24 TSSOP, 28 QFN	Yes	Yes	Yes	No	Yes	Yes	1.90
TPS40091 ⁴	1	2 to 4	4.5/15	0.7/3.3	Var	30/phase	Adj. to 1000	1	24 TSSOP, 28 QFN	Yes	Yes	Yes	No	Yes	Yes	1.90
TPS40132	1	2	1/40	0.6/5.8	1	50	Adj. to 1000	0.8	32 QFN	Yes	Yes	Yes	Yes	Yes	Yes	2.95
TPS40140 ⁵	1 or 2	1 or 2	2/40	0.7/5.8	1.2	25/phase	Adj. to 1000	0.5	36 QFN	Yes	Yes	Yes	Yes	Yes	Yes	3.05
TPS40180 ⁶	1	1	2/40	0.7/5.8	1.2	25	Adj. to 1000	0.75	24 QFN	Yes	Yes	Yes	Yes	Yes	Yes	2.05

Support Devices

TPS40120	6-bit digitally programmed feedback divider with VRM 10.x VID code table								14 TSSOP	—						0.49
----------	--	--	--	--	--	--	--	--	----------	---	--	--	--	--	--	------

Device	Switched Outputs	LDO Outputs	Phases	V _{IN} (min/max) (V)	V _O (min/max) (V)	Driver Current (A)	Output Current (A) ¹	Frequency (kHz)	V _{REF} Tol (%)	Control Method	Bootstrap Diode	Package(s)	Overshoot Protection	Power Good	DDR ⁷	Price*
DC/DC Synchronous Buck Controllers with Light-Load Efficiency																
TPS53219	1	0	1	4.5/2.8	0.6/5.5	2	25	Select up to 1000	0.5	D-CAP Mode™	Yes	16 QFN	Yes	Yes	No	1.35
TPS59116	1	1	1	3/28	1.5/3.0	0.8	10	Up to 400	1	Current, D-CAP Mode	No	20 PowerPAD™, 24 QFN	Yes	Yes	Yes	1.30
TPS59124	2	0	1	3/28	0.76/5.5	3	10	300, 360, 420	1	D-CAP Mode	No	24 QFN	Yes	Yes	No	1.90
TPS59621	1	0	2	3/30	0.3/1.5	8	54	250 to 500	0.5	D-CAP+™	Yes	40 QFN	Yes	Yes	No	1.80
TPS59610/11	1	0	1	3/30	0.3/1.5	8	27	200 to 500	0.5	D-CAP+	Yes	32 QFN	Yes	Yes	No	1.40

Device	Synch	Switched Outputs	LDO Outputs	V _{IN} (min/max) (V)	V _O (min/max) (V)	Driver Current (A)	Output Current (A) ¹	Frequency (kHz)	V _{REF} Tol (%)	Control Method	Bootstrap Diode	Package(s)	Pwr Good	DDR ⁷	Remote Sense	HiRel (H) or Automotive (A) [†]	Price*
Other Topology DC/DC Controllers																	
TPS40210/1 ⁸	No	1	0	4.5/52	5/250	0.8	6	Adj. to 1000	2	Current	No	10 MSSOP/SOIC	No	No	No	A	1.10
TPS43000 ⁹	Yes	1	0	1.8/9	0.8/8	1.2	6	Adj. to 2000	2	Voltage	No	16 TSSOP	No	No	No		2.25
TPS64200/1/2/3 ¹⁰	No	1	0	1.8/6.5	1.2/6.5	—	3	—	2	Hyster	No	23 SOT	No	No	No		0.55

DC/DC Controllers Without Drivers

TL5001	Buck, boost, flyback	1	0	3.6/40	1/50	0.02	3	Adj. to 500	3	Var	No	8 PDIP/SO/SOIC	No	No	No	H, A	0.45
--------	----------------------	---	---	--------	------	------	---	-------------	---	-----	----	----------------	----	----	----	------	------

¹Current levels of this magnitude can be supported with commonly available commercial FETs.

²The controller of choice for most applications will be the source/sink version, which has two-quadrant operation and will source or sink output current.

³Binary outputs.

⁴Tri-state outputs.

⁵Stackable to 16 phases.

⁶Stackable to 8 phases, reference is trimmable.

⁷DDR = Supports DDR memory.

⁸Overshoot protection, source only.

⁹External synch pin.

¹⁰Drives high-side P-FET.

[†]Devices qualified for HiRel (H) or Automotive (A) applications are available.

Certain voltage options are not available. Different pricing may apply.

*Suggested resale price in U.S. dollars in quantities of 1,000.

Point-of-Load Solutions

→ Charge Pumps

Inductorless DC/DC Regulators (Charge Pumps) Family of Products

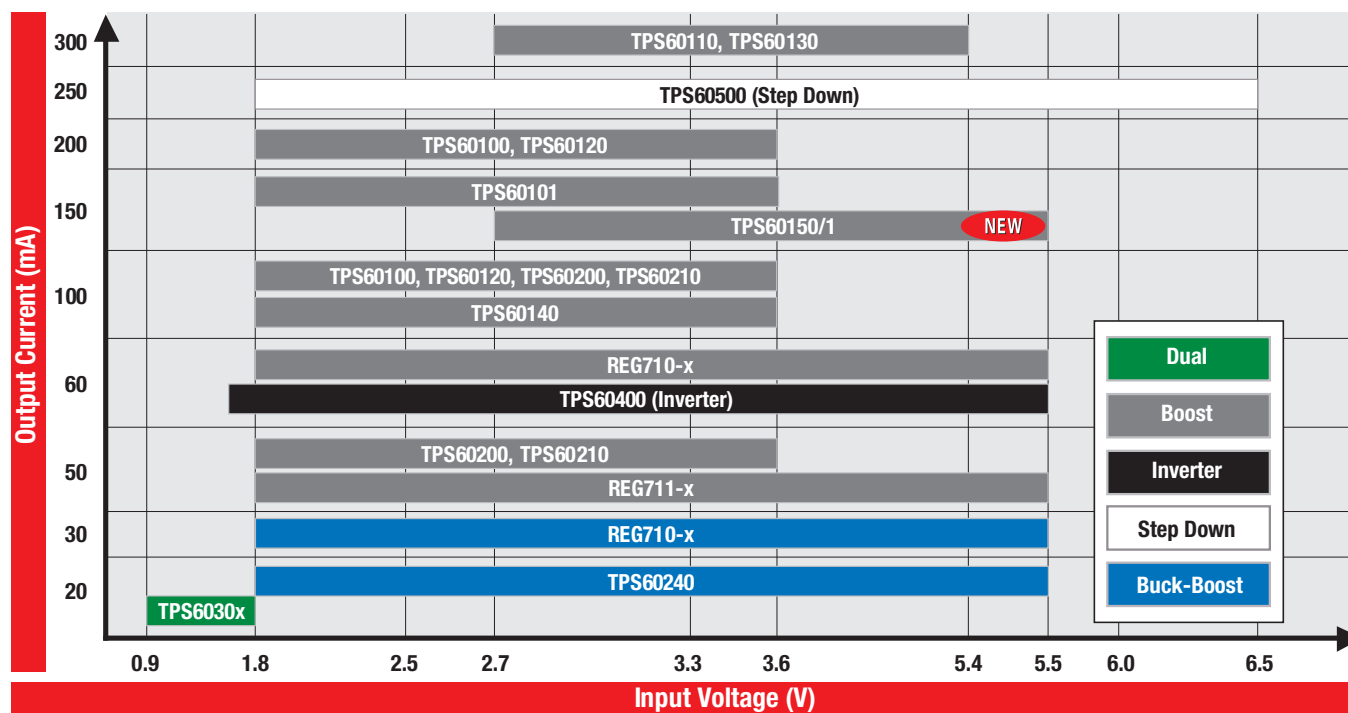

For a complete list of Resources, visit: power.ti.com

Point-of-Load Solutions

→ Charge Pumps

Selection Guide

Device	I _{OUT} (mA)	V _{IN} (V)	V _{OUT} Adj. (V)	V _{OUT} Fixed (V)	Efficiency (%)	Switching Frequency (max) (kHz)	Quiescent Current (typ) (μA)	Shutdown Current (typ) (μA)	Features							Package(s)				EVM	HiRel (H) or Automotive (A) [†]	Price*
									Shutdown	Low Battery	Power Good	Undervoltage Lockout	Current Limit	Thermal Limit	SOT-23	QFN	MSOP	TSSOP				
Step-Down (Buck) Regulators																						
TPS60500	250	1.8 to 6.5	0.8 to 3.3	—	90	1200	40	0.05	✓		✓	✓	✓	✓			10		✓	0.65		
TPS60501	250	1.8 to 6.5	—	3.3	90	1200	40	0.05	✓		✓	✓	✓	✓			10			0.65		
TPS60502	250	1.8 to 6.5	—	1.8	90	1200	40	0.05	✓		✓	✓	✓	✓			10			0.65		
TPS60503	250	1.8 to 6.5	—	1.5	90	1200	40	0.05	✓		✓	✓	✓	✓			10			0.65		
Boost Regulators																						
TPS60100	200	1.8 to 3.6	—	3.3	90	300	50	0.05	✓			✓	✓				20	✓		0.80		
TPS60101	100	1.8 to 3.6	—	3.3	90	300	50	0.05	✓			✓	✓				20			0.65		
TPS60110	300	2.7 to 5.4	—	5.0	90	300	60	0.05	✓			✓	✓				20	✓		0.85		
TPS60111	150	2.7 to 5.4	—	5.0	90	300	60	0.05	✓			✓	✓				20			0.75		
TPS60120/1	200	1.8 to 3.6	—	3.3	85	450	55	0.05	✓	✓ ¹	✓ ¹	✓	✓				20	✓		0.85		
TPS60122/3	100	1.8 to 3.6	—	3.3	85	450	55	0.05	✓	✓ ¹	✓ ¹	✓	✓				20			0.70		
TPS60124/5	200	1.8 to 3.6	—	3.0	85	450	55	0.05	✓	✓ ¹	✓ ¹	✓	✓				20			0.85		
TPS60130/1	300	2.7 to 5.4	—	5.0	90	450	60	0.05	✓	✓ ¹	✓ ¹	✓	✓				20	✓		0.90		
TPS60132/3	150	2.7 to 5.4	—	5.0	90	450	60	0.05	✓	✓ ¹	✓ ¹	✓	✓				20			0.80		
TPS60140/1	100	1.8 to 3.6	—	5.0	70	450	65	0.05	✓	✓ ¹	✓ ¹	✓	✓				20	✓		0.70		
TPS60150/1	140	2.7 to 5.5	—	5.0	90	1500	4.7	0.01	✓					✓		6		✓		0.50		
TPS60200/1	100	1.8 to 3.6	—	3.3	90	400	40	0.05	✓	✓ ¹	✓ ¹	✓	✓			10		✓		0.70		
TPS60202/3	50	1.8 to 3.6	—	3.3	90	400	40	0.05	✓	✓ ¹	✓ ¹	✓	✓			10				0.60		
TPS60204/5	100	1.8 to 3.6	—	3.3	90	400	35	0.05	✓	✓ ¹	✓ ¹	✓	✓			10				0.80		
TPS60210/1	100	1.8 to 3.6	—	3.3	90	400	35	2	Snooze	✓ ¹	✓ ¹	✓	✓			10		✓		0.80		
TPS60212/3	50	1.8 to 3.6	—	3.3	90	400	35	2	Snooze	✓ ¹	✓ ¹	✓	✓			10				0.70		
TPS60230	125	2.7 to 6.5	—	5.5 ²	85	1250	160	0.1	✓			✓	✓	✓		16		✓		0.48		
TL7660	20	1.5 to 10	—	< 2 V _{IN}	99	10.35	80	—							8	8				0.72		
Dual-Output Regulators																						
TPS60300/2	20	0.9 to 1.8	—	3.3	90	900	35	1	✓		✓ ³	✓				10		✓		0.70		
TPS60301/3	20	0.9 to 1.8	—	3.0	90	900	35	1	✓		✓ ³	✓				10				0.70		
TPS60310/2	20	0.9 to 1.8	—	3.3	90	900	35	2	Snooze		✓ ³	✓				10				0.65		
TPS60311/3	20	0.9 to 1.8	—	3.0	90	900	35	2	Snooze		✓ ³	✓				10				0.65		
Buck-Boost Regulators																						
REG710-2.5	30	1.8 to 5.5	—	2.5	90	1000	65	0.01	✓				✓	✓	6					0.45		
REG710-2.7	30	1.8 to 5.5	—	2.7	90	1000	65	0.01	✓				✓	✓	6					0.45		
REG710-3	30	1.8 to 5.5	—	3.0	90	1000	65	0.01	✓				✓	✓	6					0.45		
REG710-3.3	30	1.8 to 5.5	—	3.3	90	1000	65	0.01	✓				✓	✓	6			✓		0.45		
REG71050	60	2.7 to 5.5	—	5.0 ²	90	1000	65	0.01	✓				✓	✓	6			✓		0.55		
REG710-5	60	2.7 to 5.5	—	5.0 ²	90	1000	65	0.01	✓				✓	✓	6			✓		0.45		
REG71055	60	3.0 to 5.5	—	5.5 ²	90	1000	65	0.01	✓				✓	✓	6				A	0.55		
REG711-2.5	50	1.8 to 5.5	—	2.5	90	1000	60	0.01	✓				✓	✓		8				0.50		
REG711-2.7	50	1.8 to 5.5	—	2.7	90	1000	60	0.01	✓				✓	✓		8				0.50		
REG711-3	50	1.8 to 5.5	—	3.0	90	1000	60	0.01	✓				✓	✓		8				0.50		
REG711-3.3	50	1.8 to 5.5	—	3.3	90	1000	60	0.01	✓				✓	✓		8				0.50		
REG711-5	50	2.7 to 5.5	—	5.0	90	1000	60	0.01	✓				✓	✓		8				0.50		
TPS60240	12	1.8 to 5.5	—	3.3	90	160	25	0.1					✓	✓		8				0.55		
TPS60241	12	2.7 to 5.5	—	5.0	90	160	25	0.1					✓	✓		8		✓		0.55		
TPS60242	12	1.8 to 5.5	—	3.0	90	160	25	0.1					✓	✓		8				0.55		
TPS60243	12	1.8 to 5.5	—	2.7	90	160	25	0.1					✓	✓		8				0.55		
Inverting Regulators																						
LT1054	100	3.5 to 15	—	-5.0	—	25	2500	100	✓											1.44		
TPS60400	60	1.6 to 5.5	—	-(1.6 to 5.5)	99	50 to 250	125	—							5			✓	A	0.33		
TPS60401	60	1.6 to 5.5	—	-(1.6 to 5.5)	99	28	65	—							5				A	0.33		
TPS60402	60	1.6 to 5.5	—	-(1.6 to 5.5)	99	70	120	—							5				A	0.33		
TPS60403	60	1.6 to 5.5	—	-(1.6 to 5.5)	99	300	425	—							5				A	0.33		

¹Features apply respectively to device numbers shown. For example, only the TPS60120 has the Low Battery feature and only the TPS60121 has the Power Good feature.

²White LED driver.

³Feature applies only to second device shown. For example, only the TPS60302 has the Power Good feature.

[†]Devices qualified for HiRel (H) or Automotive (A) applications are available. Different pricing may apply.

*Suggested resale price in U.S. dollars in quantities of 1,000.

New devices are listed in bold red.

Point-of-Load Solutions

→ Digital PWM Controllers and Drivers

TI's family of Fusion Digital Power™ products focuses on two areas: Digital Power Controllers (UCD9K), complementary Power Stage solutions (UCD7K), and PTD-series modules. These products are power-management specific and are well-suited for applications where the desire exists for configurability, communications, diagnostics and adaptive control solutions. They include both isolated and non-isolated solutions from AC line to point-of-load, covering uninterruptible power supplies (UPS), server, telecom and datacom applications. The Digital Power ICs provide cost-effective solutions with greater levels of performance, reliability and flexibility than today's pure analog designs. For the most up-to-date information on digital power technology and product availability, go to:

www.ti.com/digitalpower

Key Benefits

- High levels of integration:
 - Multiple outputs and phases with one controller
 - Integrated supply-voltage sequencing, monitoring and margining
 - Improved reliability with fewer parts
- Advanced functionality:
 - Real-time power monitoring, data logging and failure prediction
 - Flexible control for varying operation modes and load characteristics
 - Calibration in manufacturing
- System optimization:
 - Easily set fault limits, start characteristics after system is assembled
 - Enhanced phase management

Digital Solution Features

- Supports PMBus™ Version 1.1
- Power + Designer Graphical User Interface tool
- Programmable soft-start/stop configuration
- Supports voltage sequencing and tracking
- Supports voltage margining and monitoring
- Supports pre-biased, monotonic start-up
- Multiple levels of fault protection with selectable response
- Hardware-accelerated digital compensator
- Supports load sharing on multiphase power stages
- Supports frequency synchronization
- Supports digital monitoring of power-supply parameters

UCD9K Buck Controllers Family

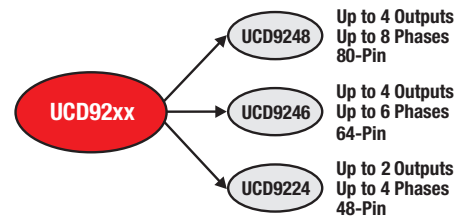

Digital Power Stage Solutions

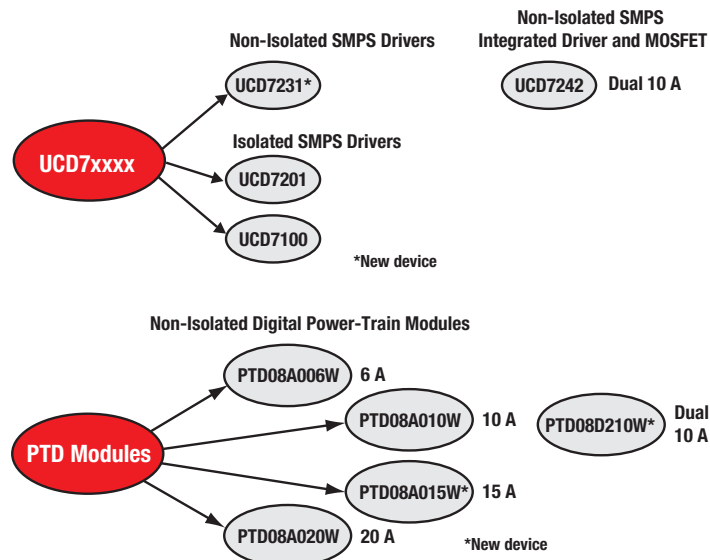

Point-of-Load Solutions

➔ Digital PWM Controllers and Drivers

Digital Point-of-Load Controller

UCD9248

Get samples and datasheets at: www.ti.com/sc/device/UCD9248

Key Features

- Controls up to 8 power stages and up to 4 voltage-feedback control loops
- Output voltage is configurable from 0.4 to 4.0 V
- Flexible configuration permits control of:
 - Four single or two dual power stages,
 - Two 4-phase power stages, or
 - One 2-, 4-, 6- or 8-phase power stage
- Supports switching frequencies of up to 2 MHz
- Supports conversion ratio of 12:1 at 2 MHz with 250-ps duty-cycle resolution
- ± 1 -mV feedback resolution
- Hardware-accelerated, digital 3-pole/3-zero compensator
- Can synchronize PWM clocks between multiple UCD9248 devices
- Enhanced nonvolatile memory with error-correction coding (ECC)

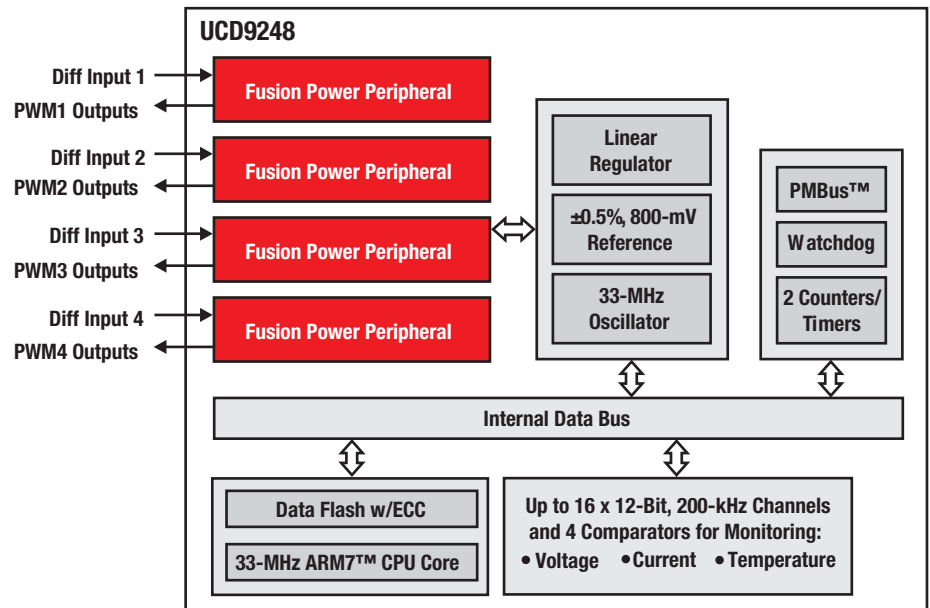

UCD9248 controller overview.

Fusion Digital Power™ Designer

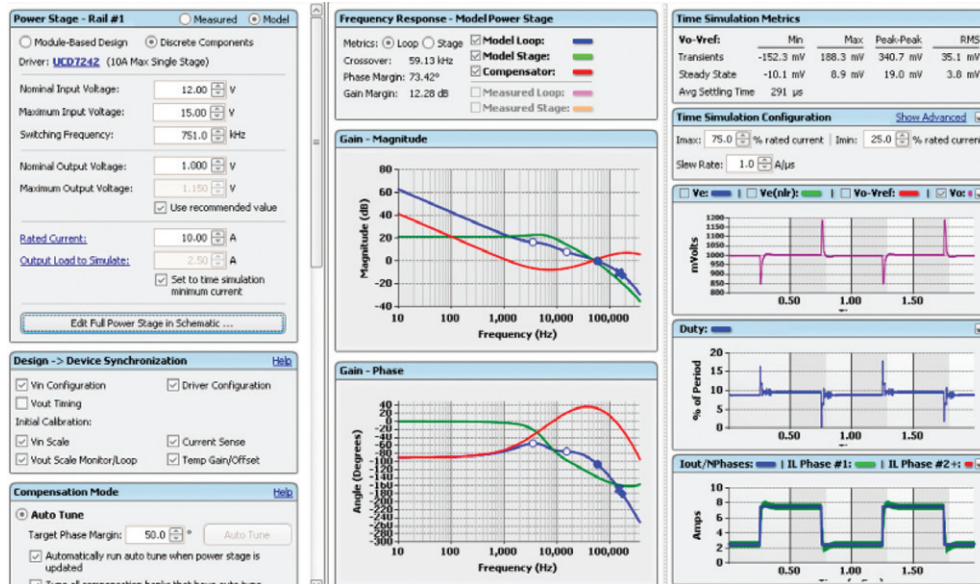

GUI Digital Power developer tool simplifies the design process.

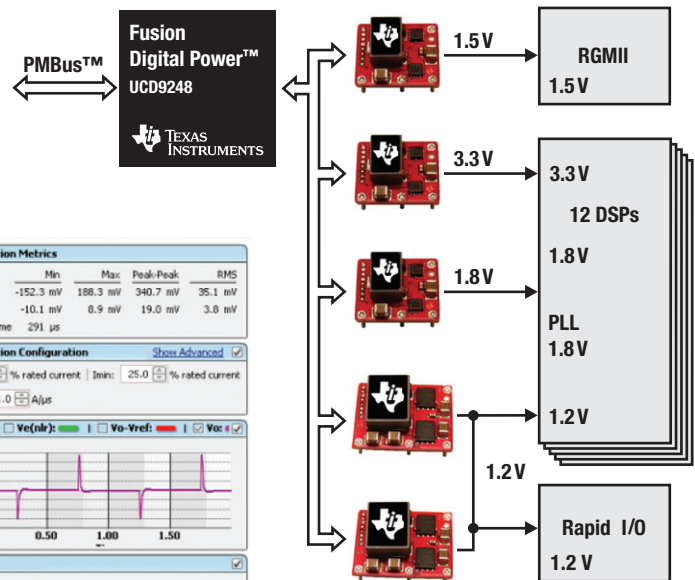

Multiprocessor, multiple-supply-rail systems (three single-phase outputs and one dual-phase output) featuring UCD9248 and first-generation PTD modules.

Point-of-Load Solutions

→ Digital PWM Controllers and Drivers

Selection Guide

Device	Pin Count	Number of Outputs	Number of Phases	Maximum Fs (MHz)	PWM Resolution (ps)	Compensator	Nonvolatile Memory	Price*
Digital Point-of-Load Controllers								
UCD9222/44²	48/64	2/4	1	2	250	3-pole/3-zero	3-pole/3-zero	3.15/5.85
UCD9224	48	2	4	2	250	3-pole/3-zero	3-pole/3-zero	2.65
UCD9248/6	80/64	4	8/6	2	250	3-pole/3-zero	Yes w/ECC	4.85/4.50

Device	Number of Outputs	Output Configuration	Output Type ¹	Peak I _{OUT} Source/Sink (A)	Rise/Fall Time (ns)	V _{CC} Range (V)	Propagation Delay (ns)	Input Threshold	Dead-Time Control	Protection Features	Price*
Digital Power MOSFET Drivers											
UCD7231	2	Non-inverting	CMOS	6/6	10/10	4.5 to 15.5	25	CMOS/TTL	Adaptive	Adjustable	0.60
UCD7232	2	Non-inverting	CMOS	6/6	10/10	4.5 to 15.5	25	CMOS/TTL	Adaptive	Adjustable	0.60
UCD7100	1	Uncommitted/Non-inverting	TrueDrive™	4/4	10/10	4.5 to 16	20	CMOS/TTL	Adaptive	Adjustable	0.99
UCD7201	2	Uncommitted/Non-inverting	TrueDrive	4/4	10/10	4.5 to 16	20	CMOS/TTL	Adaptive	Adjustable	1.20

¹Output type: TrueDrive is the hybrid bipolar/CMOS output architecture for improved current drive capability at low voltages (at Miller threshold).

²UCD9222 and UCD9244 digital PWM controllers with support for TMS320C6670 and TMS320C6678 DSPs VID interface.

*Suggested resale price in U.S. dollars in quantities of 1,000.

New devices are listed in bold red.

Preview devices are listed in bold blue.

Device	Input Voltage (V)	Output Configuration	Current Rating (A)	Price*
Digital Power Integrated Driver/MOSFET				
UCD7242	4.5 to 18	Dual	10/10	2.65
UCD74106	4.5 to 14	Single	6	1.00
UCD74103	4.5 to 14	Single	3	0.95

*Suggested resale price in U.S. dollars in quantities of 1,000.

Device	Input Voltage (V)	Output Configuration	Current Rating (A)	Price*
Digital Power-Train Modules				
PTD08A006W	4.75 to 14	Single	6	6.90
PTD08A010W	4.75 to 14	Single	10	8.50
PTD08A015W	4.75 to 14	Single	15	9.80
PTD08A020W	4.75 to 14	Single	20	12.90
PTD08D210W	4.5 to 18	Dual	10/10	9.25
PTD08A210W	4.5 to 18	Single	10	7.50

New devices are listed in bold red. Preview devices are listed in bold blue.

Point-of-Load Solutions

→ Non-Isolated Power Modules

Non-Isolated Plug-In Power Modules (POLA™ and Others) Family of Products

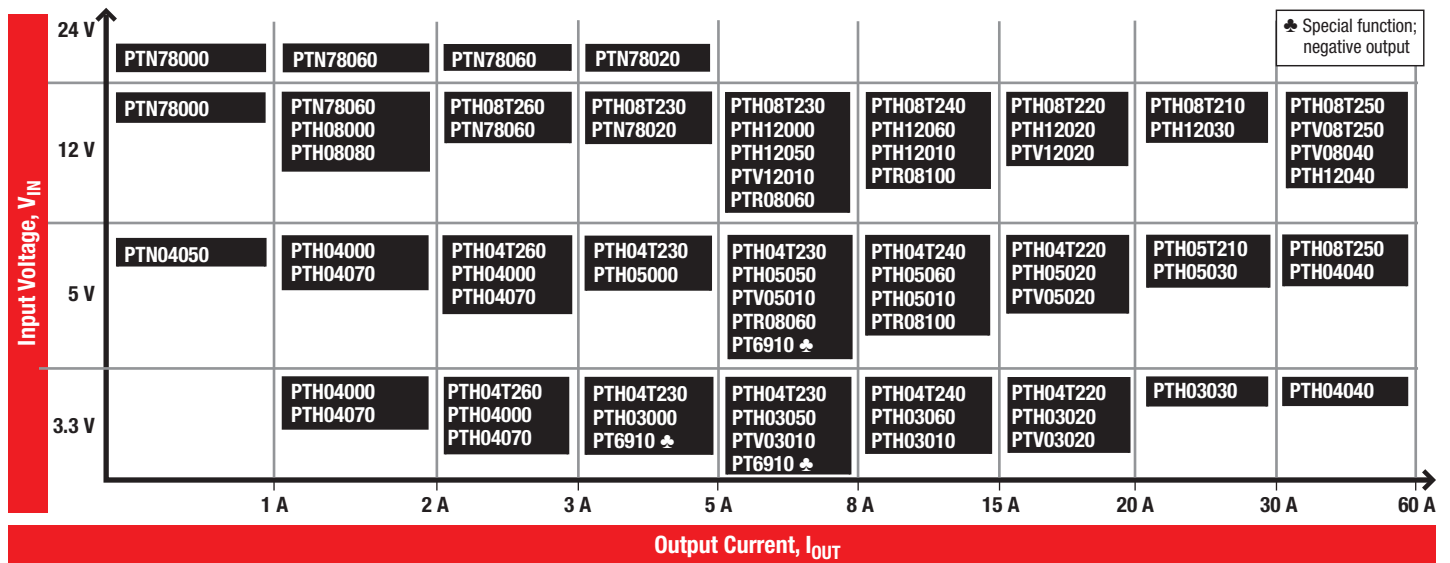

16-A, 4.5-V to 14-V Input, POL Module with TurboTrans™ Technology

PTH08T220W

Get samples, datasheets and app reports at: www.ti.com/sc/device/PTH08T220W

The PTH08T220W is a high-performance, 16-A-rated, T2 point-of-load (POL) power module. Operating from an input voltage range of 4.5 V to 14 V, the PTH08T220W requires a single resistor

to set the output voltage to any value over the range of 0.7 V to 5.5 V. The PTH08T220W incorporates TurboTrans technology, SmartSync and Auto-Track™ sequencing.

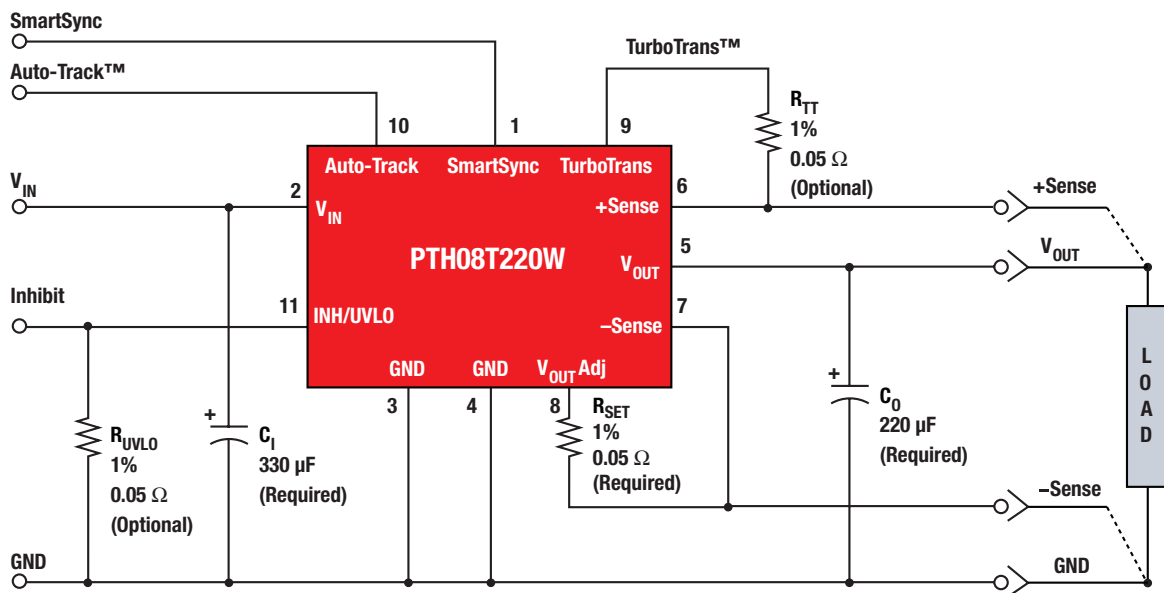

Point-of-Load Solutions

→ Non-Isolated Power Modules

Selection Guide

Device ¹	Input Bus Voltage	Description	P _{OUT} or I _{OUT}	V ₀ Range (V)	V ₀ Adj.	Auto-Track™ Sequencing	POLA™	DDR-QDR	Price*
Non-Isolated Single Positive Output									
PTH03000W	3.3 V	3.3-V Input 6-A POL	6 A	0.8 to 2.5	✓				6.90
PTH03010W	3.3 V	3.3-V Input 15-A POL with Auto-Track Sequencing	15 A	0.8 to 2.5	✓	✓	✓		11.60
PTH03020W	3.3 V	3.3-V Input 22-A POL with Auto-Track Sequencing	22 A	0.8 to 2.5	✓	✓	✓		18.15
PTH03030W	3.3 V	3.3-V Input 30-A POL with Auto-Track Sequencing	30 A	0.8 to 2.5	✓	✓	✓		25.00
PTH03050W	3.3 V	3.3-V Input 6-A POL with Auto-Track Sequencing	6 A	0.8 to 2.5	✓	✓	✓		6.90
PTH03060W	3.3 V	3.3-V Input 10-A POL with Auto-Track Sequencing	10 A	0.7 to 2.5	✓	✓	✓		9.80
PTH04000W	3.3 V/5 V	3-V to 5.5-V Input 3-A POL with Auto-Track Sequencing	3 A	0.9 to 3.6	✓	✓	✓		4.50
PTH04070W	3.3 V/5 V	3-V to 5.5-V Input 3-A POL	3 A	0.9 to 3.6	✓				4.28
PTH04040W	3.3 V/5 V	3-V to 5.5-V Input 60-A POL with Auto-Track Sequencing	60 A	0.8 to 3.6	✓	✓	✓		35.00
PTH04T220/221W	3.3 V/5 V	2.2- to 5.5-V Input, 16-A T2 2nd Gen PTH POL with TurboTrans™	16 A	0.7 to 3.6	✓	✓	✓		12.60
PTH04T230/231W	3.3 V/5 V	2.2- to 5.5-V Input, 6-A T2 2nd Gen PTH POL with TurboTrans	6 A	0.7 to 3.6	✓	✓			7.90
PTH04T240/241W	3.3 V/5 V	2.2- to 5.5-V Input, 10-A T2 2nd Gen PTH POL with TurboTrans	10 A	0.7 to 3.6	✓	✓			10.80
PTH04T260/261W	3.3 V/5 V	2.2- to 5.5-V Input, 6-A T2 2nd Gen PTH POL with TurboTrans	3 A	0.7 to 3.6	✓	✓			6.25
PTH05000W	5 V	5-V Input 6-A POL	6 A	0.8 to 3.6	✓				6.90
PTH05010W	5 V	5-V Input 15-A POL with Auto-Track Sequencing	15 A	0.8 to 3.6	✓	✓	✓		11.60
PTH05020W	5 V	5-V Input 22-A POL with Auto-Track Sequencing	22 A	0.8 to 3.6	✓	✓	✓		18.15
PTH05030W	5 V	5-V Input 30-A POL with Auto-Track Sequencing	30 A	0.8 to 3.6	✓	✓	✓		25.00
PTH05050W	5 V	5-V Input 6-A POL with Auto-Track Sequencing	6 A	0.8 to 3.6	✓	✓	✓		6.90
PTH05060W	5 V	5-V Input 10-A POL with Auto-Track Sequencing	10 A	0.8 to 3.6	✓	✓	✓		9.80
PTH05T210W	5 V	5-V Input, 30-A T2 2nd Gen PTH POL with TurboTrans	30 A	0.7 to 3.6	✓	✓	✓		18.00
PTH08000W	5 V/12 V	4.5-V to 18-V Input, 2.25-A POL with Auto-Track Sequencing	2.25 A	0.9 to 5.5	✓	✓	✓		4.50
PTH08080W	5 V/12 V	4.5-V to 18-V Input, 2.25-A POL	2.25 A	0.9 to 5.5	✓				4.28
PTH08T210W	12 V	5.5- to 14-V Input, 30-A T2 2nd Gen PTH POL with TurboTrans	30 A	0.7 to 3.6	✓	✓	✓		18.00
PTH08T220/221W	5 V/12 V	4.5- to 14-V Input, 16-A T2 2nd Gen PTH POL with TurboTrans	16 A	0.7 to 5.5	✓	✓	✓		12.60
PTH08T230/231W	5 V/12 V	4.5- to 14-V Input, 6-A T2 2nd Gen PTH POL with TurboTrans	6 A	0.7 to 5.5	✓	✓			7.90
PTH08T240/241W	5 V/12 V	4.5- to 14-V Input, 10-A T2 2nd Gen PTH POL with TurboTrans	10 A	0.7 to 5.5	✓	✓			10.80
PTH08T240F	5 V/12 V	4.5- to 14-V Input, 10-A T2 2nd Gen PTH POL for 3-GHz DSP Systems	10 A	0.7 to 2.0	✓	✓			10.80
PTH08T250/255W	5 V/12 V	4.5- to 14-V Input, 50-A T2 2nd Gen PTH POL with TurboTrans	50 A	0.7 to 5.5	✓	✓			36.00
PTH08T260/261W	5 V/12 V	4.5- to 14-V Input, 3-A T2 2nd Gen PTH POL with TurboTrans	3 A	0.7 to 5.5	✓	✓			6.25
PTH12000L/W	12 V	12-V Input 6-A POL	6 A	0.8 to 1.8/1.2 to 5.5	✓				6.90
PTH12010L/W	12 V	12-V Input 12-A POL with Auto-Track Sequencing	12 A	0.8 to 1.8/1.2 to 5.5	✓	✓	✓		11.60
PTH12020L/W	12 V	12-V Input 18-A POL with Auto-Track Sequencing	18 A	0.8 to 1.8/1.2 to 5.5	✓	✓	✓		18.15
PTH12030L/W	12 V	12-V Input 26-A POL with Auto-Track Sequencing	26 A	0.8 to 1.8/1.2 to 5.5	✓	✓	✓		25.00
PTH12040W	12 V	12-V Input 50-A POL with Auto-Track Sequencing	50 A	0.8 to 5.5	✓	✓	✓		35.00
PTH12050L/W	12 V	12-V Input 6-A POL with Auto-Track Sequencing	6 A	0.8 to 1.8/1.2 to 5.5	✓	✓	✓		6.90
PTH12060L/W	12 V	12-V Input 10-A POL with Auto-Track Sequencing	10 A	0.8 to 1.8/1.2 to 5.5	✓	✓	✓		9.80
PTH03010Y	3.3 V	3.3-V Input 15-A DDR Terminating Module	15 A	Follows V _{REF}	✓		✓	✓	11.60
PTH03050Y	3.3 V	3.3-V Input 6-A DDR Terminating Module	6 A	Follows V _{REF}	✓		✓	✓	6.90
PTH03060Y	3.3 V	3.3-V Input 10-A DDR Terminating Module	10 A	Follows V _{REF}	✓		✓	✓	9.80
PTH05010Y	5 V	5-V Input 15-A DDR Terminating Module	15 A	Follows V _{REF}	✓		✓	✓	11.60
PTH05050Y	5 V	5-V Input 6-A DDR Terminating Module	6 A	Follows V _{REF}	✓		✓	✓	6.90
PTH05060Y	5 V	5-V Input 10-A DDR Terminating Module	10 A	Follows V _{REF}	✓		✓	✓	9.80
PTH12010Y	12 V	12-V Input 12-A DDR Terminating Module	12 A	Follows V _{REF}	✓		✓	✓	11.60
PTH12050Y	12 V	12-V Input 6-A DDR Terminating Module	6 A	Follows V _{REF}	✓		✓	✓	6.90
PTH12060Y	12 V	12-V Input 8-A DDR Terminating Module	8 A	Follows V _{REF}	✓		✓	✓	9.80
PTN04050C	3.3 V/5 V	3-V/5-V Input, 12-W Output Step-Up (Boost) ISR	12 W	5 to 15	✓				8.00
PTN78000W/H	V ₀ + 2 to 36 V	Wide-Input, Wide-Output 1.5-A Positive Step-Down ISR	1.5 A	2.5 to 12/12 to 22	✓				8.00
PTN78060W/H	V ₀ + 2 to 36 V	Wide-Input, Wide-Output 3-A Positive Step-Down ISR	3 A	2.5 to 12/12 to 22	✓				11.00
PTN78020W/H	V ₀ + 2 to 36 V	Wide-Input, Wide-Output 6-A Positive Step-Down ISR	6 A	2.5 to 12/12 to 22	✓				15.00
PTR08060W	5 V/12 V	4.5- to 14-V Input, 6-A POL	6 A	0.6 to 5.5	✓				6.00
PTR08100W	5 V/12 V	4.5- to 14-V Input, 10-A POL	10 A	0.6 to 5.5	✓				8.00
PTV03010W	3.3 V	5-V Input 8-A Vertical SIP with Auto-Track Sequencing	8 A	0.8 to 2.5	✓	✓	✓		6.90
PTV03020W	3.3 V	5-V Input 18-A Vertical SIP with Auto-Track Sequencing	18 A	0.8 to 2.5	✓	✓	✓		11.60

¹See power.ti.com for a complete product offering.

*Suggested resale price in U.S. dollars in quantities of 1,000.

Point-of-Load Solutions

→ Non-Isolated Power Modules

Selection Guide (Continued)

Device ¹	Input Bus Voltage	Description	P _{OUT} or I _{OUT}	V ₀ Range (V)	V ₀ Adj.	Auto-Track™ Sequencing	POLA™	DDR-QDR	Price*
Non-Isolated Single Positive Output (Continued)									
PTV05010W	5 V	5-V Input 8-A Vertical SIP with Auto-Track Sequencing	8 A	0.8 to 3.6	✓	✓	✓		6.90
PTV05020W	5 V	5-V Input 18-A Vertical SIP with Auto-Track Sequencing	18 A	0.8 to 3.6	✓	✓	✓		11.60
PTV08T250W	12 V	8-V to 14-V Input, 50-A T2 2nd Gen PTH POL with TurboTrans	50 A	0.8 to 3.6	✓	✓			36.00
PTV12010L/W	12 V	12-V Input 8-A Vertical SIP with Auto-Track Sequencing	8 A	0.8 to 1.8/1.2 to 5.5	✓	✓	✓		6.90
PTV12020L/W	12 V	12-V Input 18-A Vertical SIP with Auto-Track Sequencing	16 A	0.8 to 1.8/1.2 to 5.5	✓	✓	✓		11.60
Non-Isolated Single Negative Output									
PTN04050A	3.3 V/5 V	3-V to 5-V Input, 6-W Positive to Negative (Buck-Boost) ISR	6 W	-3.3 to -15	✓				8.00
PTN78000A	7 to 29 V	Wide-Input, Wide-Output 1.5-A Positive to Negative (Buck-Boost) ISR	1.5 A	-3 to -15	✓				8.00
PTN78060A	9 to 29 V	Wide-Input, Wide-Output 15-W Positive to Negative (Buck-Boost) ISR	15 W	-3 to -15	✓				11.00
PTN78020A	9 to 29 V	Wide-Input, Wide-Output 25-W Positive to Negative (Buck-Boost) ISR	25 W	-3 to -15	✓				15.00

¹See power.ti.com for a complete product offering.

*Suggested resale price in U.S. dollars in quantities of 1,000.

NexFET™ Power MOSFETs



TI's premier power management innovation called NexFET™ technology, combines vertical current flow with a lateral power MOSFET. It provides a low on resistance and requires an extremely low gate charge with industry-standard package outlines—a combination not previously possible with existing silicon platforms.

NexFET technology delivers high performance for both N- and P-channel power MOSFET devices. Designers are able to achieve 90% power supply efficiencies from light to full loads with high output currents and low duty cycles, representing a breakthrough in discrete designs.

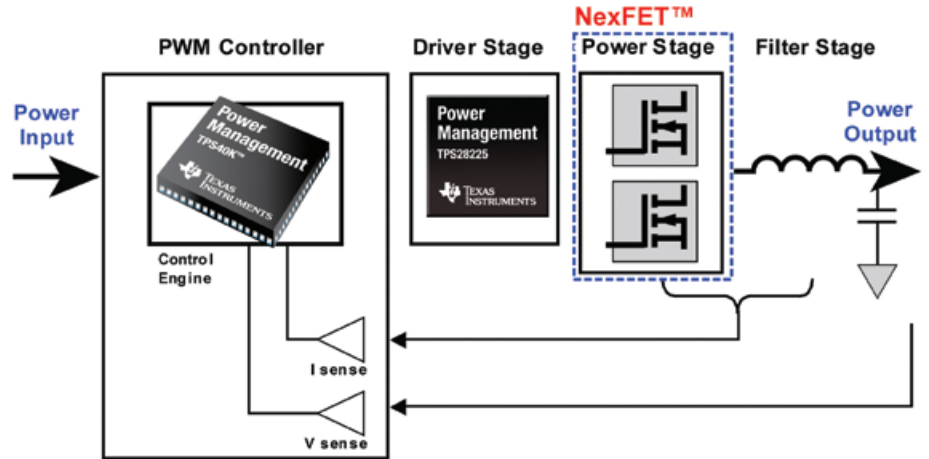

System block diagram of TI electronics in a power system design.

	NexFET™ Technology	Industry Standard
Control FET	$R_{DS(on)} = 5.8 \text{ m}\Omega$	$R_{DS(on)} = 6.6 \text{ m}\Omega$
	$Q_G = 6.5 \text{ nC}$	$Q_G = 12.3 \text{ nC}$
Sync FET	$R_{DS(on)} = 2.5 \text{ m}\Omega$	$R_{DS(on)} = 2.3 \text{ m}\Omega$
	$Q_G = 13.2 \text{ nC}$	$Q_G = 39.8 \text{ nC}$

Technology comparison.

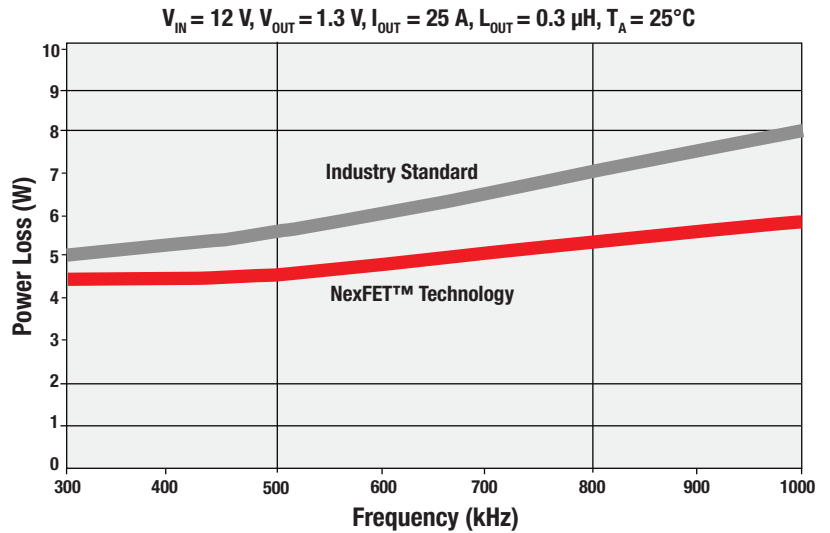

Same power loss, double the frequency.

For additional resources on NexFET™ devices, please visit: www.ti.com/nexfet

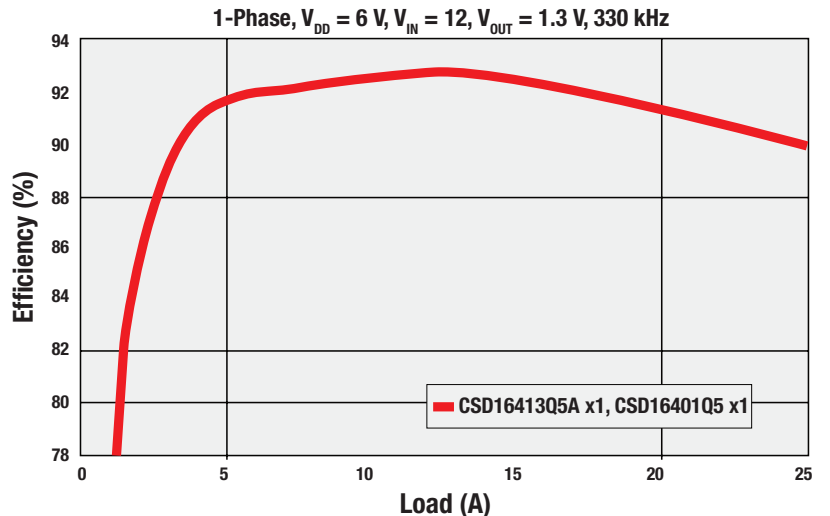

90% efficiency from light to full load.



Selection Guide

Device	Channel	V _{DS} (V)	V _{GS} (V)	Typical V _{GS(th)} (V)	Typical R _{DS(on)} (mΩ)						Maximum I _D (A)	Typical Q _G at 4.5 V (nC)	Typical Q _{GS} (nC)	Typical Q _{GD} (nC)	Typical R _G (Ω)
					at 10 V	at 4.5 V	at 3 V	at 2.5 V	at 1.8 V	at 1.5 V					
WLP 1x1															
Single															
CSD23201W10	P	12	6	0.6	—	66	—	77	—	110	2.2	1.9	0.28	0.26	—
WLP 1x1.5															
Single															
CSD25301W1015	P	20	8	0.75	—	62	—	80	—	175	2.2	1.9	0.35	0.4	—
Common Source															
CSD75205W1015	P	20	6	0.65	—	95	—	115	145	—	1.2	1.6	0.3	0.4	—
CSD75301W1015	P	20	8	0.7	—	80	—	105	150	—	1.2	1.5	0.28	0.3	—
WLP 1.5x1.5															
Single															
CSD25201W15	P	20	6	0.7	—	33	—	42	52	—	4	4.3	1	0.7	—
Common Source															
CSD75204W15	P	20	6	0.7	—	40	—	53	70	—	3	2.8	0.5	0.6	—
WLP 1.7x2.3															
Dual															
CSD86311W1723	N	25	10	1	—	31	—	37	—	—	4.5	2.8	0.7	0.6	—
CSD75211W1723	P	20	8	0.7	—	32	—	61	80	—	4.5	4.5	0.9	0.9	—
SON 2x2															
Single															
CSD16301Q2	N	25	10	1.1	—	23	27	—	—	—	5	2	0.6	0.4	1.3
CSD17313Q2	N	30	10	1.3	—	26	31	—	—	—	5	2.1	0.7	0.4	1.3
CSD25302Q2	P	20	8	0.65	—	39	—	56	71	—	5	2.6	0.54	0.5	—
SON 3x3															
Single															
CSD16411Q3	N	25	16	2	8	12	—	—	—	—	56	2.9	1.5	0.7	0.8
CSD16409Q3	N	25	16	2	6.2	9.5	—	—	—	—	60	4	2.1	1	0.9
CSD16406Q3	N	25	16	1.8	4.2	5.9	—	—	—	—	60	5.8	2.5	1.5	1.2
CSD16323Q3	N	25	10	1.1	—	4.4	5.4	—	—	—	60	6.2	1.8	1.1	1.4
CSD16340Q3	N	25	10	0.85	—	4.3	—	6.1	—	—	60	6.5	2.1	1.2	1.5
CSD17308Q3	N	30	10	1.3	—	9.4	12.5	—	—	—	47	3.9	1.3	0.8	0.9
CSD17304Q3	N	30	10	1.3	—	6.9	9.8	—	—	—	56	5.1	1.8	1.1	1.1
CSD17309Q3	N	30	10	1.2	—	4.9	6.3	—	—	—	60	7.5	2.5	1.7	1.2
CSD25401Q3	P	20	12	0.85	—	8.8	—	13.5	—	—	60	8.8	2.1	2.1	1.2
SON 5x6															
Single															
CSD16412Q5A	N	25	16	2	9	13	—	—	—	—	52	2.9	1.4	0.7	0.7
CSD16410Q5A	N	25	16	1.9	6.8	9.6	—	—	—	—	59	3.9	1.8	1.1	0.7
CSD16404Q5A	N	25	16	1.8	4.1	5.7	—	—	—	—	81	6.5	3	1.7	0.9
CSD16408Q5	N	25	16	1.8	3.6	5.4	—	—	—	—	113	6.7	3.1	1.9	0.8
CSD16413Q5A	N	25	16	1.6	3.1	4.1	—	—	—	—	100	9	3.5	2.5	0.9
CSD16403Q5A	N	25	16	1.6	2.2	2.9	—	—	—	—	100	13.3	5.5	3.5	1.2
CSD16407Q5	N	25	16	1.6	1.8	2.5	—	—	—	—	100	13.3	5.3	3.5	1.2
CSD16414Q5	N	25	16	1.6	1.5	2.1	—	—	—	—	100	16.6	7.3	4.4	1.4
CSD16401Q5	N	25	16	1.5	1.3	1.8	—	—	—	—	100	21	8.3	5.2	1.2
CSD16322Q5	N	25	10	1.1	—	4.6	5.4	—	—	—	97	6.8	2.4	1.3	1.1
CSD16321Q5	N	25	10	1.1	—	2.1	2.8	—	—	—	100	14	4	2.5	1.5
CSD16325Q5	N	25	10	1.1	—	1.7	2.1	—	—	—	100	18	6.6	3.5	1.6
CSD17307Q5A	N	30	10	1.3	—	9.7	12.8	—	—	—	73	4	1.3	1	0.9
CSD17302Q5A	N	30	10	1.2	—	7.3	9.5	—	—	—	87	5.4	1.7	1.2	0.8
CSD17310Q5A	N	30	10	1.3	—	4.5	5.7	—	—	—	100	8.9	2.7	2.1	0.9
CSD17306Q5A	N	30	10	1.1	—	3.3	4.2	—	—	—	100	11.8	3.5	2.4	1



Selection Guide (Continued)

Device	Channel	V _{DS} (V)	V _{GS} (V)	Typical V _{GS(th)} (V)	Typical R _{DS(on)} (mΩ)						Maximum I _D (A)	Typical Q _G at 4.5 V (nC)	Typical Q _{GS} (nC)	Typical Q _{GD} (nC)	Typical R _G (Ω)
					at 10 V	at 4.5 V	at 3 V	at 2.5 V	at 1.8 V	at 1.5 V					
SON 5x6 (Continued)															
Single (Continued)															
CSD17305Q5A	N	30	10	1.1	—	2.8	3.9	—	—	—	100	14.1	4.5	3	1
CSD17301Q5A	N	30	10	1.1	—	2.3	2.9	—	—	—	100	19	5.7	4.3	1.3
CSD17303Q5	N	30	10	1.1	—	2	2.7	—	—	—	100	18	5.6	4	1.4
CSD17311Q5	N	30	10	1.2	—	1.8	2.3	—	—	—	100	24	6.6	5.2	1.2
CSD17312Q5	N	30	10	1.1	—	1.4	1.8	—	—	—	100	28	8.4	6	1.1
CSD17501Q5A	N	30	20–12	1.3	2.4	3	—	—	—	—	187	13.2	5.4	3.5	—
CSD17505Q5A	N	30	20–12	1.3	2.9	3.7	—	—	—	—	153	10	3.5	2.7	—
CSD17506Q5A	N	30	20–12	1.3	3.2	4.2	—	—	—	—	150	8.3	3.1	2.3	—
CSD17507Q5A	N	30	20–12	1.6	9	11.8	—	—	—	—	85	2.8	1.3	0.7	—
CSD17510Q5A	N	30	20–12	1.5	4.1	5.4	—	—	—	—	129	6.4	2.7	1.9	—
DualCool™ SON 5x6															
Single															
CSD16408Q5C	N	25	16	1.8	3.6	5.4	—	—	—	—	113	6.7	3.1	1.9	0.8
CSD16407Q5C	N	25	16	1.6	1.8	2.5	—	—	—	—	100	13.3	5.3	3.5	1.2
CSD16322Q5C	N	25	10	1.1	—	4.6	5.4	—	—	—	97	6.8	2.4	1.3	1.1
CSD16321Q5C	N	25	10	1.1	—	2.1	2.8	—	—	—	100	14	4	2.5	1.5
CSD16325Q5C	N	25	10	1.1	—	1.7	2.1	—	—	—	100	18	6.6	3.5	1.6
Device	Channel	Integrated Driver	V _{DS} (V)	V _{GS} (V)	Power Loss (W)	P _{loss} Current (A)	Max Current (A)	Max f _{sw} (MHz)							
SON 3x3 PowerBlock															
CSD86330Q3D	N	No	25	10	1.9	15	20	1.5							
SON 5x6 PowerBlock and QFN 5x6 PowerStage															
CSD86350Q5D	N	No	25	10	2.8	25	40	1.5							
CSD96370Q5M	N	Yes	25	—	2.6	25	40	2.0							

→ Overview

The Texas Instruments portfolio of isolated power-conversion solutions covers the complete end-to-end power-supply building blocks from front-end PFC controllers to PWM controllers that support the most popular isolated-power topologies, including the advanced phase-shifted full-bridge. The portfolio also includes a variety of MOSFET gate drivers that support both primary and secondary MOSFET-driver applications, including synchronous-rectifier driver topologies and many other power-supply support products.

Power-Supply Solutions

- PFC controllers:
 - Transition mode
 - Continuous-current mode
 - Interleaved
- PWM controllers:
 - Single-ended: Flyback, forward, active-clamp
 - Double-ended: Half-bridge, phase-shifted full-bridge, push-pull, LLC half-bridge
 - UCD3K digital control solutions
- MOSFET drivers:
 - Synchronous-rectifier driver
 - Single low-side
 - Dual low-side
 - 110-V high-side/low-side
 - Synchronous-buck

What's New

- UCC28950: Green phase-shifted full-bridge with synchronous-rectifier outputs
- UCC24610: Green Rectifier™
- UCC28250: Half-bridge with synchronous-rectifier outputs
- UCC28610: Flyback PWM controller
- UCC2897A: Active-clamp forward

Design Factors

Control Method

Average-Current Mode (ACM) — Optimum control method to achieve PFC and low harmonic distortion.

Transition Mode (TM) — Simpler, inexpensive control with high peak currents and filtering requirements.

Interleaved — TM- and ACM-compatible multiphase, high-power, high-density topology. Delivers better EMI, smaller magnetics and reduced ripple currents.

Zero-Voltage-Transition (ZVT) Mode

— A type of soft-switching technique, which reduces EMI and allows for higher frequency operations.

Protection

- Overvoltage protection (OVP) prevents output capacitor, switches and load from overcharge condition.
- Soft-start (programmable) provides controlled start-up.
- Overcurrent protection (OCP) provides protection during overload conditions.

Performance

- Voltage feed-forward for linearized performance and faster transient response over wide line voltage range.
- Multiplier linearity and zero power detect functions improve light load operation.
- Onboard high output current drive capability without external MOSFET drivers.

Flexibility

- Ability to work with a wide line voltage range.
- Different levels of undervoltage lockout thresholds for self bias and auxiliary bias applications.
- Ability to synchronize controllers to eliminate noise issues.

Power Level

- IEC requirements are applicable to all power supplies above 75 W.
- Higher power converters may require zero-current-switching (ZCS) and ZVT-switching techniques to achieve high efficiencies.
- Some of the simpler control techniques not usable at high power levels.

Features

- From 50 W to 5 kW, TI PFC controllers deliver EN61000-3-2 compliance.
- Industry standard architecture.
- Deliver PF > 0.993.
- New BiCMOS generation reduces complexity.
- Optimized PFC/PWM “combo” controllers.
- Superior applications support.

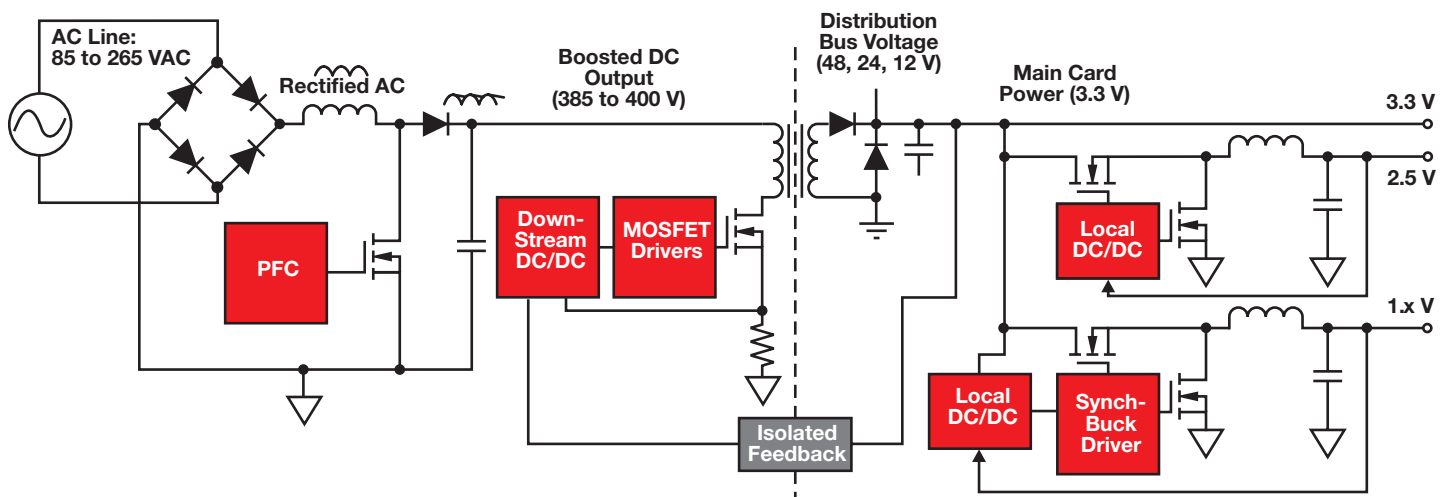

→ Power Factor Correction (PFC)

Interleaved PFC

Interleaved PFC is gaining popularity in external and embedded-type power-supply architectures. It is exceptionally flexible and provides many cost-saving features such as passive-component size reductions, smaller EMI filtering components and higher efficiencies. TI offers both transition mode (UCC28060) and continuous conduction mode (CCM) (UCC28070) control methods.

Other benefits of interleaving include scalability and ultrathin designs. Scalability allows for addressing many different power levels and applications.

www.ti.com/sc/device/UCC28060

www.ti.com/sc/device/UCC28061

www.ti.com/sc/device/UCC28070

Why Interleave?

- Lower system cost from ripple-current cancellation
- Enables ultraslim and high-density designs
- Lower total inductor volume
- Smaller or lower-cost EMI filter and output capacitors
- Facilitates higher efficiency

Applications

- Digital TV
- Telecom power supplies and rectifiers
- Professional and consumer audio
- Merchant power supplies
- Air conditioning and refrigeration compressors
- Variable-speed motors
- Low-profile power-supply applications

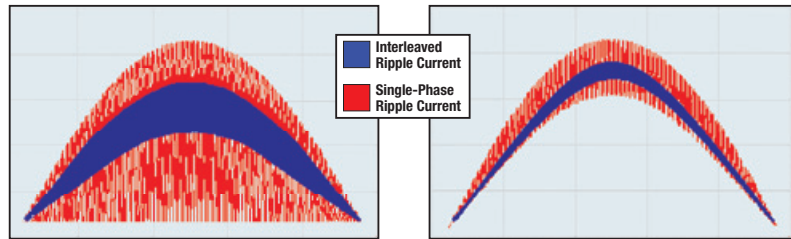

UCC28060 transition mode PFC with Natural Interleaving™ technique.

UCC28070 continuous conduction mode PFC.

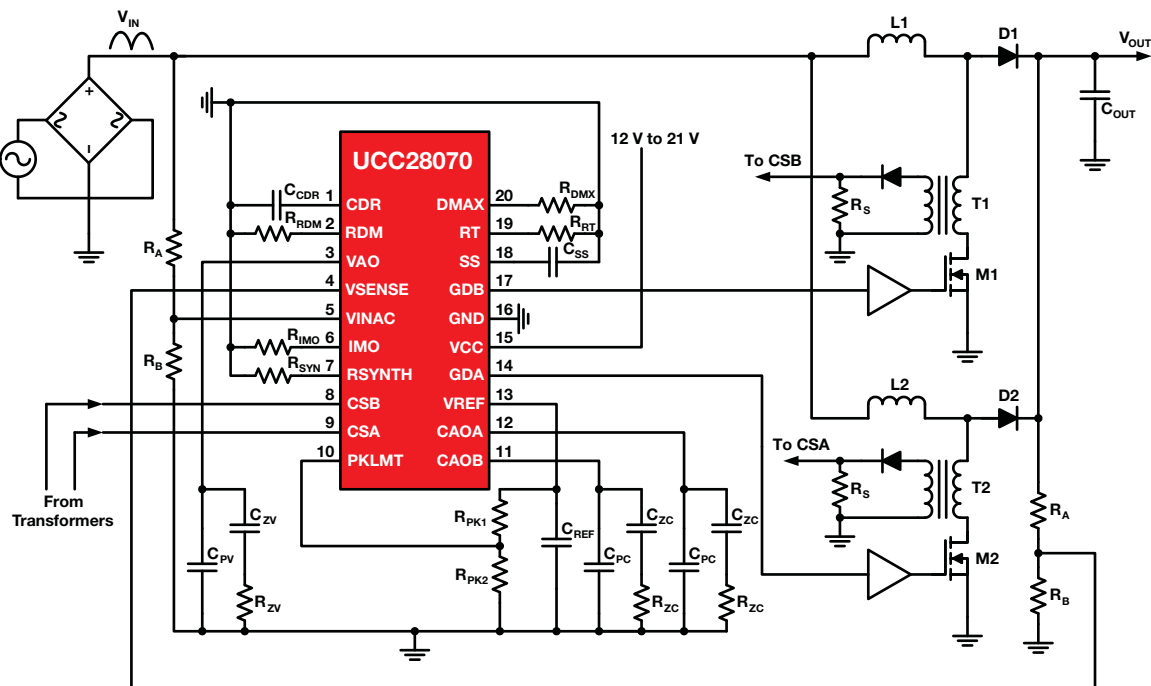

Typical application for UCC28070 continuous conduction mode PFC.

Isolated Solutions

→ PWM Power Supply Controllers

Single-Ended Topologies

Control Method

Voltage Mode — Simple, low-noise control method for wide input and output range requirements.

Current Mode — Fast transient response with built-in current limiting.

Level of Integration

- Integrated soft-start (programmable) provides predictable start-up.
- Internal leading edge blanking to suppress switching spike from MOSFET turn-on.

Performance

- Many voltage mode controllers have input voltage feedforward for instantaneous response to input line changes.
- Most controllers have onboard high current drive capability without external MOSFET drivers.
- Lower start-up current for offline applications (for BiCMOS products with UCC prefix).
- Low operating current (for BiCMOS products with UCC prefix) for light-load efficiency.
- Programmable minimum duty cycle clamp for light-load efficiency (UCC3581).

Features

- 10-W to 350-W offline and DC/DC power supplies.
- Single-ended topology power supplies, buck, boost, flyback and forward.

Double-Ended Topologies

Current Mode — Control technique featuring fast transient response with inherent cycle-by-cycle current limiting.

Voltage Mode — Versatile, low-noise control method for wide duty cycle ranges.

Soft Switching

- Zero Voltage Transition (ZVT) soft switching techniques minimize power loss at turn-on.
- Phase shifted, ZVT controllers maximize efficiency in full-bridge converters.

Protection

- Flexible overcurrent limiting circuitry provides programmable fault protection modes.
- Programmable soft-start executes predictable start-up on initialization and after faults.

- High speed, cycle-by-cycle current limiting.
- Maximum duty cycle clamp to prevent transformer saturation.
- Programmable deadtime control to prevent cross conduction of power switches.

Hot Products

- UCC28950: Green advanced phase-shifted full-bridge and synchronous rectifier controller
- UCC28250: Advanced PWM controller with pre-bias startup and synchronous rectification
- UCC24610: Synchronous Green Rectifier™ controller
- UCC29910: Buck PFC controller
- UCC2897A: Active clamp forward
- UCC25600: LLC resonant controller
- UCC28610: Advanced green-mode flyback controller
- UCC28019A: 8-pin CCM PFC controller

Low- to Medium-Power PWM Controllers (25 W to 350 W)

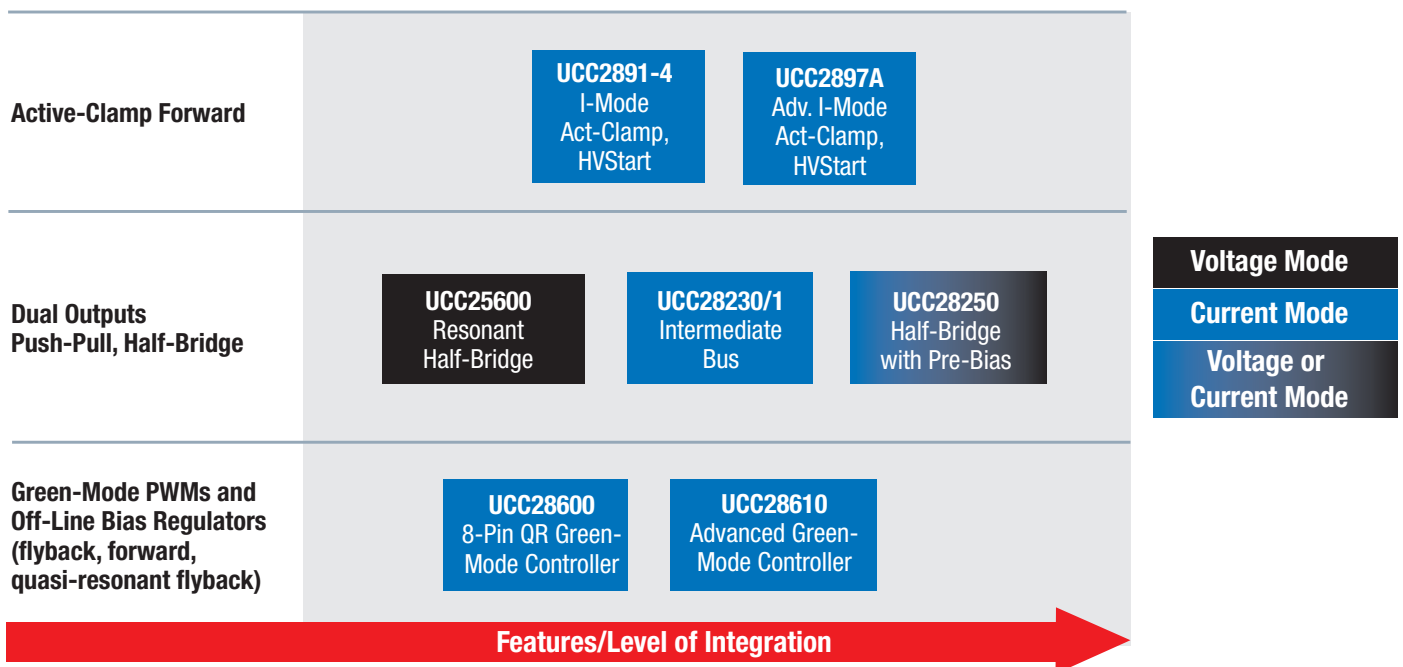

→ PWM Power Supply Controllers

Medium- to High-Power PWM Controllers (>300 W)

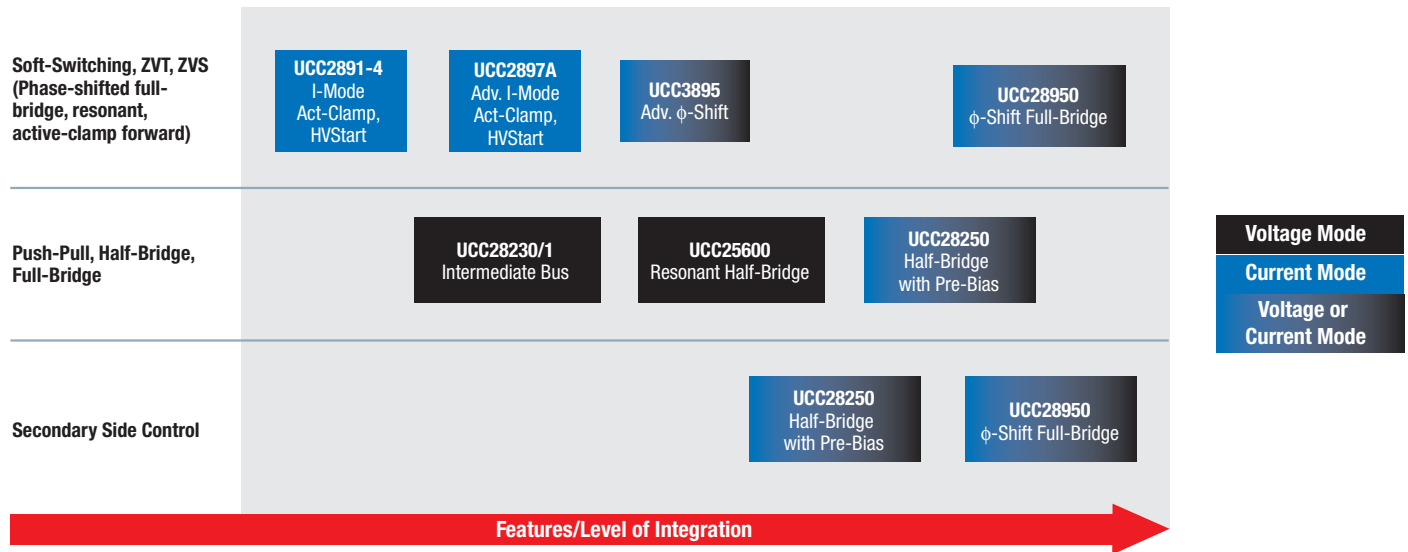

Advanced PWM Controller with Pre-Bias Operation

UCC28250

Get samples, datasheets, evaluation modules and app reports at: www.ti.com/sc/device/UCC28250

The UCC28250 PWM controller is designed for high-density power applications that may have stringent pre-biased start-up requirements. The UCC28250's integrated synchronous-rectifier control outputs target high-efficiency and high-performance topologies such as half-bridge, full-bridge, interleaved forward and push-pull.

Key Features

- Smooth pre-biased start-up feature
- Synchronous-rectifier control outputs with programmable delays, including zero delay
- Current-mode or voltage-mode control with input-voltage feed-forward
- Addresses primary-side or secondary-side use
- 3.3-V, 1.5% accurate reference output
- 1% accurate cycle-by-cycle over-current protection with matched duty-cycle outputs

Applications

- Half-bridge, full-bridge, interleaved
- Forward and push-pull isolated converters
- High-density power architectures
- Wireless base-station power
- N+1 power supplies
- Industrial power systems

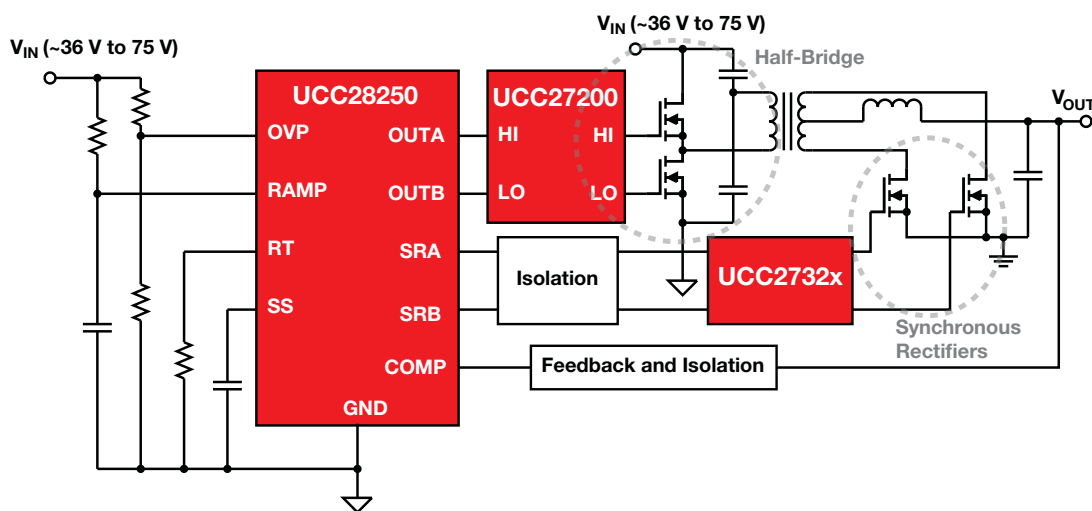

→ PWM Power Supply Controllers

Green Advanced Phase-Shifted Full-Bridge and Synchronous Rectifier Controller UCC28950

Get samples, datasheets, evaluation modules and app reports at: www.ti.com/sc/device/UCC28950

The UCC28950 phase-shifted full-bridge controller offers best-in-class efficiency in today's high-performance power systems. The UCC28950 implements advanced full-bridge control along with active control of the synchronous rectifier's output stage. The primary-side signals allow programmable delays to ensure ZVS operation over wide load current and input voltage range, while the load current naturally tunes the secondary-side synchronous rectifier's switching delays, maximizing overall system efficiency.

Key Features

- Optimized for 90+ efficiency standards
- Adaptive ZVS switching over wide input/output range
- Optimal timing outputs for synchronous-rectifier drivers
- User-programmable operation in DCM mode with lowered frequency at light load (burst)
- Programmable ramp compensation allows current- or voltage-mode control
- Sync in and sync out with 90% phase shift for master/slave interleaved operation of two modules

Applications

- Phase-shifted full-bridge converters
- Server, telecom power supplies
- Industrial power systems
- High-density power architectures
- Solar inverters
- Electric vehicles
- DC motor drives

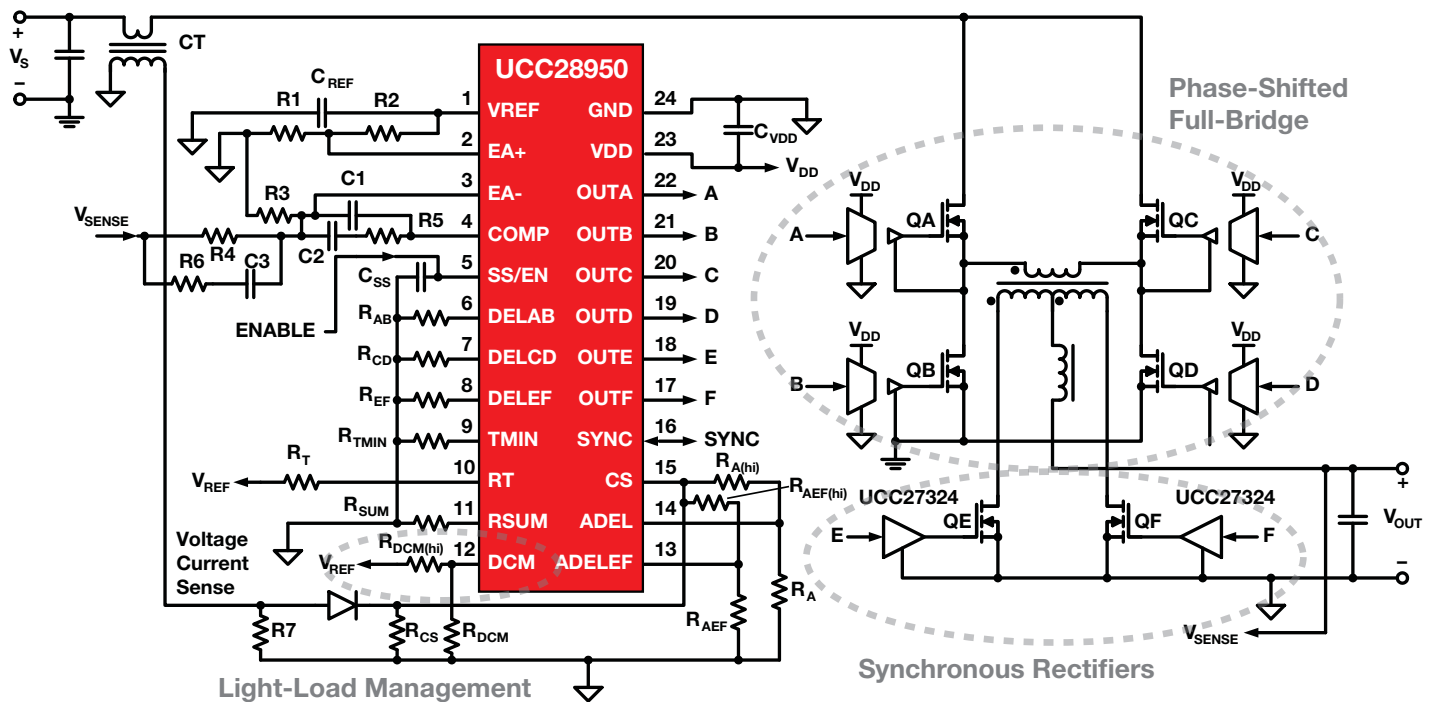

→ PWM Power Supply Controllers

Selection Guide

(Device parameters continued on next page)

Device	Typical Power Level (W)	Control Method			Topologies										Maximum Practical Frequency	Start-Up Current	Operating Current	Supply Voltage (V)	110-V Start-Up Circuit	UVLO: On/Off (V)			
		Voltage Mode	Current Mode	Avg. Current Mode	Buck	Boost	Flyback (SEPIC, Cuk)	Fwd (Including 2-Switch Fwd)	Forward (D > 50%)	Interleaved Fwd/Flyback/Boost	Act-Clamp Fwd/Flyback	Push-Pull	I-Fed/V-Fed Push-Pull	Half-Bridge							Full-Bridge	φ-Shifted FB	
Green Mode Controllers and Offline Bias Regulators																							
UCC28610	10 to 40	✓	✓	✓														140 kHz	10 μA	3.7 mA	9 to 20	—	10.7/7.55
UCC28600	50 to 150	✓																130 kHz	25 μA	50 mA	30	—	13/8
UCC3888/89	<10	✓																250 kHz	150 μA	1.2 mA	9	—	8.4/6.3
Intermediate Bus Controllers																							
UCC28230/1	150 to 500																	2 MHz	150 μA	3 mA	-0.3 to 20	—	6.6 to 6
General-Purpose Single-Ended Controllers																							
TL3842B/3B/4B/5B	30 to 350	✓	✓		✓	✓	✓	✓										500 kHz	0.3 mA	11 mA	10 to 30	—	16/10
UC28023	50 to 750	✓	✓		✓	✓	✓	✓										1 MHz	1.1 mA	22 mA	9 to 30	—	9.2/8.4
UC3823	50 to 750	✓	✓		✓	✓	✓	✓										1 MHz	1.1 mA	22 mA	9 to 30	—	9.2/8.4
UC3823A/B	50 to 750	✓	✓		✓	✓	✓	✓										1 MHz	100 μA	28 mA	9 to 22	—	9.2/8.4/16/10
UC3842A/3A/4A/5A	30 to 350	✓	✓		✓	✓	✓	✓										500 kHz	0.5/0.3 mA	11 mA	10 to 30	—	4 Options
UCC3800/1/2/3/4/5	10 to 200	✓	✓		✓	✓	✓	✓										1 MHz	100 μA	500 μA	4.1 to 15	—	5 Options
UCC3807-1-2-3	10 to 200	✓	✓		✓	✓	✓	✓										1 MHz	100 μA	1.3 mA	6.9 to 15	—	3 Options
UCC3809-1-2	10 to 200	✓	✓		✓	✓	✓	✓										1 MHz	50 μA	500 μA	8 to 19	—	2 Options
UCC3813-0/1/2/3/4/5	10 to 200	✓	✓		✓	✓	✓	✓										1 MHz	100 μA	500 μA	7.2 to 151	—	5 Options
UCC3884	50 to 250	✓	✓		✓	✓	✓	✓										1 MHz	200 μA	5 mA	8.9 to 15	—	8.9/8.3
UCC38C40/1/2/3/4/5	10 to 250	✓	✓		✓	✓	✓	✓										1 MHz	50 μA	2.3 mA	5 Options	—	5 Options
Wide-Input Range Voltage Mode Controllers																							
UCC35701/2	25 to 250	✓				✓	✓	✓										700 kHz	130 μA	750 μA	8.8 to 15	—	2 Options
UCC35705/6	25 to 250	✓				✓	✓	✓										4 MHz	50 μA	2.5 mA	8.0 to 15	—	2 Options
Dual Output Controllers																							
UCC28250	100 to 800	✓	✓				✓	✓	✓	✓	✓	✓	✓	✓	✓	✓	✓	1 MHz	150 μA	2.7 mA	4.7 to 17	—	4.6/3.8
TL494 or TL594	50 to 500	✓			✓	✓	✓	✓	✓	✓	✓	✓	✓	✓	✓	✓	✓	300 kHz	—	7.5 mA	7 to 40	—	—
TL598	50 to 500	✓			✓	✓	✓	✓	✓	✓	✓	✓	✓	✓	✓	✓	✓	300 kHz	—	15 mA	7 to 40	—	6.1/6
UC28025	50 to 750	✓	✓															1 MHz	1.1 mA	22 mA	9 to 30	—	9.2/8.4
UC3524A	50 to 500	✓																250 kHz	4 mA	5 mA	8 to 40	—	7.5/7
UC3525B - UC3526A	50 to 500	✓																250 kHz	—	14 mA	8 to 40	—	7/7
UC3824	50 to 250	✓	✓															1 MHz	1.1 mA	22 mA	9 to 30	—	9.2/8.4
UC3825	50 to 750	✓	✓															1 MHz	1.1 mA	22 mA	9 to 30	—	9.2/8.4
UC3825A/B	50 to 750	✓	✓															1 MHz	100 μA	28 mA	9 to 22	—	16/10/9.2/8.4
UC3827-1/-2	50 to 500	✓	✓															450 kHz	1000 μA	32 mA	8.4 to 20	—	9/8.4
UC3846/56	50 to 750	✓	✓															1 MHz	1.5 mA	17 mA	8 to 40	—	7.7/7
UCC28089	25 to 250																	500 kHz	130 μA	1.4 mA	8 to 15	—	10.5/8
UCC28220/1	50 to 800		✓															1 MHz/ch.	200 μA	3 mA	8 to 14.5	✓	2 Options
UCC3806	50 to 750	✓	✓															350 kHz	100 μA	1.4 mA	7 to 15	—	7.5/6.7
UCC3808-1/-2/A-1/A-2	50 to 500	✓	✓															1 MHz	130 μA	1 mA	4.3 to 15	—	12.5/8.3/4.3/4.1
UCC38083/4/5/6	50 to 500	✓	✓															1 MHz	130 μA	20 mA	8.3 to 15	—	12.5/8.3
UCC3810	50 to 500	✓	✓		✓	✓	✓	✓										1 MHz	150 μA	2 mA	8.3 to 11	—	11.3/8.3
Soft-Switching, ZVT and ZVS Controllers																							
UCC28950	200 W to 2 kW	✓	✓	✓														1 MHz	150 μA	5 mA	8 to 17	—	7.9/6.15
UCC25600	200 W to 1 kW	✓	✓															350 kHz	100 μA	7.5 mA	11.5 to 18	—	11.1/8.9
UC3875/6/7	200 W to 2 kW	✓	✓	✓														1+ MHz	150 μA	45 mA	10.7 to 20	—	10.7/9.3/15/9
UC3879	200 W to 2 kW	✓	✓															500 kHz	150 μA	27 mA	11 to 20	—	15.2/9/10.7/9
UCC2891/3	75 to 600		✓															1 MHz	300 μA	2 mA	8.5 to 14.5	✓	13/8
UCC2892/4	75 to 600		✓															1 MHz	300 μA	2 mA	8.5 to 14.5	—	13/8
UCC2897A	75 to 600		✓															1 MHz	300 μA	2 mA	8.5 to 14.5	✓	13/8
UCC3580-1/-2/-3/-4	50 to 500	✓	✓															500 kHz	100 μA	1.5 mA	7 to 15	—	15/8.5/9.8/5
UCC3895	200 W to 2 kW	✓	✓	✓														1 MHz	150 μA	5 mA	11 to 17	—	11/9
Secondary-Side, Post Regulation																							
UCC3583	50 to 500																	500 kHz	100 μA	3 mA	8.5 to 15	—	9/8.4

¹ Value varies by part number suffix. Please check datasheet.

Note: UC2xxx and UCC2xxx devices are extended temperature-range versions of the UC3xxx and UCC3xxx devices.

New devices are listed in bold red.

Isolated Solutions

→ PWM Power Supply Controllers

(Device parameters continued from previous page)

Device	V _{REF} (V)	V _{REF} Tol. (%)	Max Duty Cycle (%)	Soft Start	E/A	Shut-down Pin	Voltage Feed-forward	Output Drive (Sink/Source) (A)	Slope Comp	Sync Pin	Leading Edge Blanking	Package(s)										Price*	
												MSOP	SON	SSOP	TSSOP	HTSSOP-PowerPAD™	QFN	SOIC	SOIC-W (300 mil)	SOIC-W Power	PLCC		DIL (PDIP)
Green Mode Controllers and Offline Bias Regulators																							
UCC28610	—	—	—	—	—	—	—	—	—	—	—					8						0.60	
UCC28600	—	—	99	✓	—	—	—	1/0.75	—	—	—					8					A	0.49	
UCC3888/89	2.5	3	5.5	✓	—	—	✓	0.2/0.15	—	—	—						8			8		0.59	
Intermediate Bus Controllers																							
UCC28230/1	5 or 3.3	1.5	99	✓	—	—	—	0.2/0.2	—	—	—			12	14							1.20	
General-Purpose Single-Ended Controllers																							
TL3842B/3B/4B/5B	5	2	100	—	✓	—	—	1/1	—	—	—					8/14				8		0.54	
UC28023	5.1	1	Prog.	✓	✓	—	—	1.5/1.5	—	✓	—						16			16		1.35	
UC3823	5.1	1	Prog.	✓	✓	—	✓	1.5/1.5	—	✓	—						16		20	16		1.60	
UC3823A/B	5.1	1	Prog.	✓	✓	—	✓	2/2	—	✓	—						16		20	16		4.90	
UC3842A/3A/4A/5A	5	1.5	50 or 100	—	✓	—	—	1/1	—	—	—					8/14				8	H	0.80	
UCC3800/1/2/3/4/5	5	1.5	100	✓	✓	—	—	1/1	—	—	100 ns			8			8			8		1.35	
UCC3807-1-2-3	2 (Int)	—	Prog.	✓	✓	—	—	1/1	—	—	100 ns						8			8		1.50	
UCC3809-1-2	5	5	90	✓	—	✓	—	0.8/0.4	—	—	—	8					8			8		0.85	
UCC3813-0/1/2/3/4/5	5 ¹	2	50 or 100	✓	✓	—	—	1/1	—	—	100 ns						8			8		0.80	
UCC3884	5	2.5	100	✓	✓	—	✓	1/0.5	—	—	—						16			16		1.60	
UCC38C40/1/2/3/4/5	5	2	100	—	✓	—	—	1/1	—	—	—	8					8			8		0.95	
Wide-Input Range Voltage Mode Controllers																							
UCC35701/2	5	1.5	VS Clamp	✓	—	✓	✓	1.2/1.2	—	✓	—				14		14			14		2.95	
UCC35705/6	—	—	93	—	—	—	✓	0.1/0.1	—	—	—	8					8			8		0.75	
Dual Output Controllers																							
UCC28250	3.3	1.5	50	✓	✓	—	✓	—	✓	—	✓			20	20							1.70	
TL494 or TL594	5	5	45	—	✓	—	—	0.2/0.2	—	✓	—			16			16			16	H	0.23	
TL598	5	1	45	—	✓	—	—	0.2/0.2	—	✓	—						16			16	H	0.81	
UC28025	5.1	1	Prog.	✓	✓	—	—	1.5/1.5	—	✓	—						16			16		1.35	
UC3524A	5	2	Prog.	✓	✓	✓	—	0.2/0.2	—	✓	—						16			16		1.70	
UC3525B - UC3526A	5	2	Prog.	✓	✓	✓	—	0.2/0.2	—	✓	—						16		20	16		1.05	
UC3824	5.1	1	Prog.	✓	✓	—	—	1.5/1.5	—	✓	—						16			16		4.55	
UC3825	5.1	1	Prog.	✓	✓	—	—	1.5/1.5	—	✓	—						16		20	16	H	1.60	
UC3825A/B	5.1	1.5	Prog.	✓	✓	—	—	2/2	—	✓	—						16		20	16		2.65	
UC3827-1/-2	5	4	—	✓	✓	—	—	1/0.8	—	✓	—						24		28	24		3.50	
UC3846/56	5	2	Prog.	✓	✓	—	—	0.5/0.5	—	✓	—						16		20	16	H	1.60	
UCC28089	—	—	50	✓	—	—	—	0.5/1.0	—	✓	—						8					0.65	
UCC28220/1	3.3	4.5	Prog.	✓	—	—	—	0.01/0.01	Prog.	—	—				16		16				H, A	1.60	
UCC3806	5.1	3	Prog.	✓	✓	✓	—	0.5/0.5	—	✓	—			16	16		16	16		20	16	H	4.10
UCC3808-1/-2/A-1/A-2	—	—	Prog.	✓	✓	—	—	1.0/0.5	—	✓	—			8			8			8		1.30	
UCC38083/4/5/6	5	2	50	✓	—	—	—	1.0/0.5	Prog.	—	—			8			8			8		1.10	
UCC3810	5	2	50	—	✓	✓	—	1/1	—	✓	—						16			16		1.85	
Soft-Switching, ZVT and ZVS Controllers																							
UCC28950	5	1.5	50	✓	✓	—	—	—	—	✓	✓			24								4.25	
UCC25600	—	—	Variable	✓	—	—	—	0.4/0.8	—	—	—						8					0.80	
UC3875/6/7	5	2	Prog.	✓	✓	—	—	Four at 2/2	—	✓	—								20	28	20	4.85	
UC3879	5	2.5	Prog.	✓	✓	—	—	Four at 0.1/0.1	—	✓	—						20			28	20	3.70	
UCC2891/3	5	1	Prog.	✓	—	✓	—	2/2, 2/2	Prog.	✓	—				16		16					1.50	
UCC2892/4	5	1	Prog.	✓	—	✓	—	2/2, 2/2	Prog.	✓	—				16		16					1.50	
UCC2897A	5	1	Prog.	✓	—	✓	—	2/2, 2/2	Prog.	✓	—				20		16					1.50	
UCC3580-1/-2/-3/-4	5	1	Prog.	✓	✓	✓	✓	0.5/1, 0.3/0.3	—	—	—						16			16		2.40	
UCC3895	5	3	Prog.	✓	✓	✓	—	Four at 0.1/0.1	—	✓	—						20		20	20		4.35	
Secondary-Side, Post Regulation																							
UCC3583	5	1.5	9.5	✓	✓	—	—	0.5/1.5	—	✓	—						14			20	14	1.75	

¹Value varies by part number suffix. Please check datasheet.

Note: UC2xxx and UCC2xxx devices are extended temperature-range versions of the UC3xxx and UCC3xxx devices.

†Devices qualified for HiRel (H) or Automotive (A) applications are available.

Different pricing may apply.

*Suggested resale price in U.S. dollars in quantities of 1,000.

New devices are listed in bold red.

→ MOSFET Drivers

Design Factors

Supply Voltage Range — With internal voltage regulators, MOSFET drivers can operate over a wide input voltage range, making them flexible for many applications.

Number of Outputs — Single and dual drivers are available to complement DC/DC switching and motor control applications.

Output Configuration — Inverting, non-inverting, AND and NAND configurations are available.

TrueDrive™ Output Stage — Used in TI high-current gate drivers and controllers, the TrueDrive output architecture is constructed of bipolar and CMOS transistors in parallel. TrueDrive technology delivers high current where it is needed most—at the MOSFET Miller plateau region thresholds—and provides switching efficiency gains.

Predictive Gate Drive™ Technology

— This patented TI technology is a digital control technique to control delay times in high-efficiency, low-output-voltage synchronous buck converters. See our application notes on Predictive Gate Drive for a complete description.

Synchronous Green Rectifier™ Controller

UCC24610

Get samples, datasheets and evaluation modules at: www.ti.com/sc/device/UCC24610

The UCC24610 Green Rectifier™ controller is a high-performance controller and driver for n-channel MOSFETs used for low-voltage secondary-side synchronous rectification. The combination of controller and MOSFET emulates a near-ideal diode rectifier. This solution directly reduces power dissipation of the rectifier and improves overall power-supply efficiency.

Key Features

- Secondary-side synchronous-rectifier controller for flyback and LLC converters

- Operates in continuous- and discontinuous-mode flybacks and is LLC-resonant
- Automatic light-load management
- Highly integrated control
- Micropower sleep current at light/no load

Applications

- AC/DC adapters
- Mobile chargers for cell phones, MP3 players
- Set-top box
- Appliance power supplies
- Bias supplies

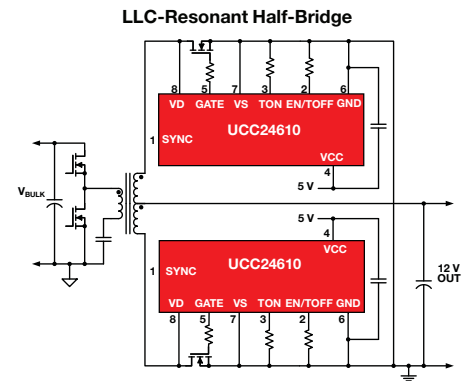
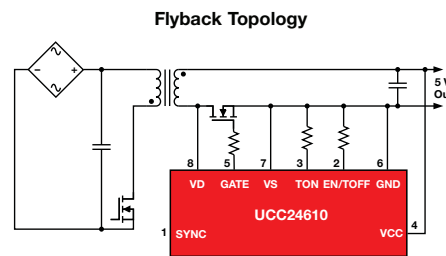

MOSFET Drivers Family of Products

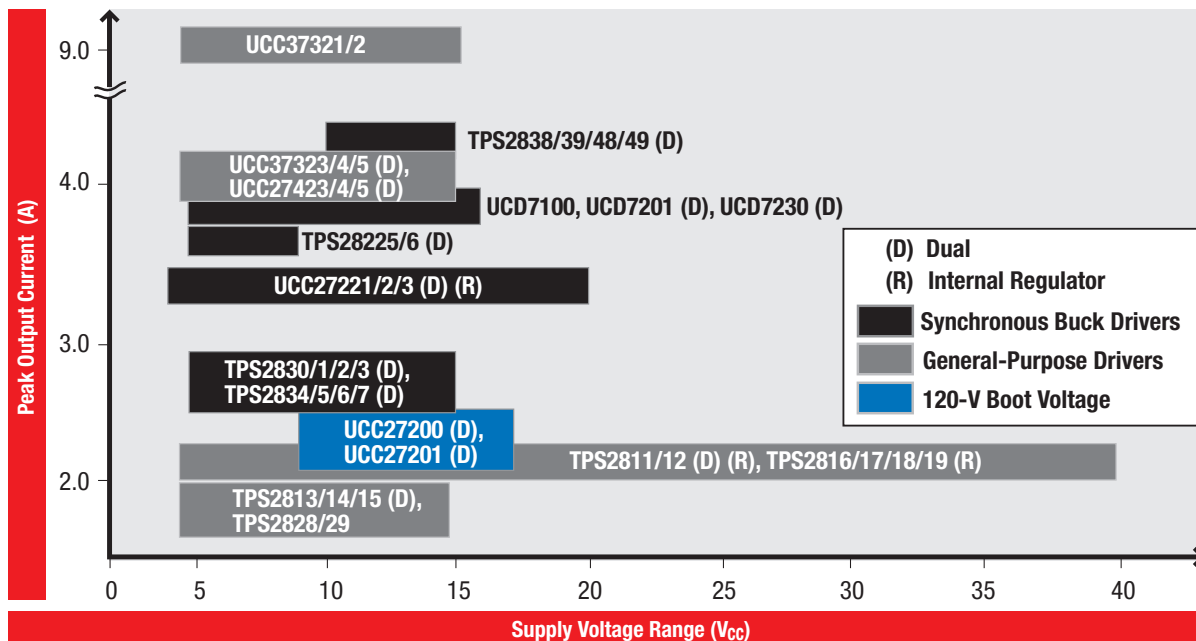

→ MOSFET Drivers

Selection Guide

Device	No. of Outputs	Output Configuration	Output Type ¹	Peak I _{OUT} Source/Sink (A)	Rise/Fall Time (ns)	V _{CC} Range (V)	Prop Delay (ns)	Input Threshold	Enable	Dead Time Control	Protection Features ²	Internal Regulator	HiRel (H) or Automotive (A) [†]	Price*
General-Purpose Low-Side Drivers														
TPS2811	2	Inverting	TrueDrive™	2.0/2.0	25/25	4 to 40	40	CMOS	—	—	—	✓	A	0.90
TPS2812	2	Non-inverting	TrueDrive	2.0/2.0	25/25	4 to 40	40	CMOS	—	—	—	✓		0.90
TPS2813	2	See Note 3	TrueDrive	2.0/2.0	25/25	4 to 14	40	CMOS	—	—	—	✓		0.90
TPS2814	2	Dual 2-input AND; one inverting	TrueDrive	2.0/2.0	25/25	4 to 14	40	CMOS	—	—	—	—		0.90
TPS2815	2	2-input NAND	TrueDrive	2.0/2.0	25/25	4 to 14	40	CMOS	✓	N/A	—	—		0.90
TPS2816	1	Inverting	TrueDrive	2.0/2.0	25/25	4 to 40	40	CMOS	—	N/A	—	✓		0.65
TPS2817	1	Non-inverting	TrueDrive	2.0/2.0	25/25	4 to 40	40	CMOS	—	N/A	—	✓		0.65
TPS2818	1	Inverting	TrueDrive	2.0/2.0	25/25	4 to 40	40	CMOS	—	N/A	—	✓	H	0.65
TPS2819	1	Non-inverting	TrueDrive	2.0/2.0	25/25	4 to 40	40	CMOS	—	N/A	—	✓	H	0.65
TPS2828	1	Inverting	TrueDrive	2.0/2.0	25/25	4 to 14	40	CMOS	—	N/A	—	—		0.60
TPS2829	1	Non-inverting	TrueDrive	2.0/2.0	25/25	4 to 14	40	CMOS	—	N/A	—	—	A	0.60
UC3714	2	Non-inverting	Bipolar	0.5/1.0	30/25	7 to 20	50	TTL/PWM	✓	Adj.	—	—		0.95
UC3715	2	See Note 3	Bipolar	1.0/2.0	30/25	7 to 20	50	TTL/PWM	✓	Adj.	—	—		0.90
UCC27323	2	Inverting	TrueDrive	4.0/4.0	25/25	4 to 15	35	TTL/CMOS	—	—	—	—		0.80
UCC27324	2	Non-inverting	TrueDrive	4.0/4.0	25/25	4 to 15	35	TTL/CMOS	—	—	—	—		0.80
UCC27325	2	See Note 3	TrueDrive	4.0/4.0	25/25	4 to 15	35	TTL/CMOS	—	—	—	—		0.80
UCC27423	2	Inverting	TrueDrive	4.0/4.0	25/25	4 to 15	35	TTL/CMOS	✓	—	—	—	H, A	0.75
UCC27424	2	Non-inverting	TrueDrive	4.0/4.0	25/25	4 to 15	35	TTL/CMOS	✓	—	—	—	H, A	0.75
UCC27425	2	See Note 3	TrueDrive	4.0/4.0	25/25	4 to 15	35	TTL/CMOS	✓	—	—	—	A	0.75
UCC37321	1	Inverting	TrueDrive	9/9	20/20	4 to 15	30	TTL/CMOS	✓	—	—	—		0.99
UCC37322	1	Non-inverting	TrueDrive	9/9	20/20	4 to 15	30	TTL/CMOS	✓	—	—	—		0.99
UCD7100PWP	1	Uncommitted/Non-inverting	TrueDrive	4/4	10/10	4.5 to 16	20	CMOS/TTL	—	Adaptive	—	—		0.99
UCD7201PWP	2	Uncommitted/Non-inverting	TrueDrive	4/4	10/10	4.5 to 16	20	CMOS/TTL	—	Adaptive	—	—		1.20
Synchronous-Rectifier Drivers														
UCC24610		Non-inverting	—	3/3	30/25	4.5 to 5.5	44	CMOS/TTL	✓	Adaptive	✓	—		0.75
Synchronous Buck Drivers														
TPS28225	2	Non-inverting	CMOS	2.0/4.0	10/10	4.5 to 8.8	14	TTL/CMOS	✓	Adaptive	UVLO	—		0.60
TPS28226	2	Non-inverting	CMOS	2.0/4.0	10/10	4.5 to 8.8	14	TTL/CMOS	✓	Adaptive	UVLO	—		0.60
TPS2830	2	Non-inverting	TrueDrive	2.4/2.4	50/50	4.5 to 15	75	CMOS	✓	Adaptive	OVPC	—		1.05
TPS2831	2	Inverting	TrueDrive	2.4/2.4	50/50	4.5 to 15	75	CMOS	✓	Adaptive	OVPC	—		1.05
TPS2832	2	Non-inverting	TrueDrive	2.4/2.4	50/50	4.5 to 15	75	CMOS	—	Adaptive	—	—		1.00
TPS2833	2	Inverting	TrueDrive	2.4/2.4	50/50	4.5 to 15	75	CMOS	—	Adaptive	—	—		1.00
TPS2834	2	Non-inverting	TrueDrive	2.4/2.4	30/30	4.5 to 15	70	TTL	✓	Adaptive	OVPC	—		1.05
TPS2835	2	Inverting	TrueDrive	2.4/2.4	30/30	4.5 to 15	70	TTL	✓	Adaptive	OVPC	—		1.05
TPS2836	2	Non-inverting	TrueDrive	2.4/2.4	30/30	4.5 to 15	70	TTL	—	Adaptive	—	—		1.25
TPS2837	2	Inverting	TrueDrive	2.4/2.4	30/30	4.5 to 15	70	TTL	—	Adaptive	—	—		1.25
TPS2838	2	Non-inverting	TrueDrive	4/4	120	10 to 15	40	TTL	✓	Adaptive	—	✓		1.30
TPS2839	2	Inverting	TrueDrive	4/4	120	10 to 15	40	TTL	✓	Adaptive	—	✓		1.30
TPS2848	2	Non-inverting	TrueDrive	4/4	120	10 to 15	20	TTL	✓	Adaptive	—	✓		1.25
TPS2849	2	Inverting	TrueDrive	4/4	120	10 to 15	20	TTL	✓	Adaptive	—	✓		1.25
UCC27221	2	Inverting	TrueDrive	3.3/3.3	20/20	3.7 to 20	82/103	TTL	—	PGD ⁴	—	✓		1.70
UCC27222	2	Non-inverting	TrueDrive	3.3/3.3	20/20	3.7 to 20	82/103	TTL	—	PGD ⁴	—	✓		1.70
UCC27223	2	Non-inverting	TrueDrive	3.3/3.3	25/35	4.15 to 20	82/103	TTL	✓	PGD ⁴	—	✓		1.70
UCD7230	2	Non-inverting	CMOS	4/4	10/10	4.5 to 15.5	25	CMOS/TTL	—	Adaptive	Adjustable	—		0.80
High-Side Low-Side Drivers—Half Bridge, Full Bridge														
UCC27200	2	Non-inverting	TrueDrive	3/3	10/8	to 110 ⁵	20	CMOS	—	N/A	UVLO	—	A	1.30
UCC27201	2	Non-inverting	TrueDrive	3/3	10/8	to 110 ⁵	20	TTL	—	N/A	UVLO	—	A	1.30

¹ Output type: TrueDrive is the hybrid bipolar/CMOS output architecture for improved current drive capability at low voltages (at Miller threshold).

² OVPC = overvoltage protection crowbar, UVLO = undervoltage lockout.

[†] Devices qualified for HiRel (H) or Automotive (A) applications are available. Different pricing may apply.

*Suggested resale price in U.S. dollars in quantities of 1,000.

³ One inverting, one non-inverting.

⁴ Predictive Gate Drive™.

⁵ Maximum boot voltage at HS pin.

New devices are listed in bold red.

→ Digital PWM Controllers

Isolated Digital Power-Control Solutions

UCD3020

Get samples at: www.ti.com/sc/device/UCD3020

The UCD30xx family of digital PWM controllers provides a single-chip control solution for digital power-conversion applications. These devices allow implementation of a high-performance, high-frequency power supply with supervisory, monitoring and communication functions and a flexible configuration of parameters. The UCD30xx devices are fully programmable solutions that permit single- or multiphase configurations to support a wide range of isolated and non-isolated topologies. Some examples include interleaved PFC, isolated forward, half bridge, phase-shifted full bridge, active clamp and resonant LLC.

Key Features

- Digital control of up to four voltage-feedback loops
- Up to eight high-resolution digital pulse-width-modulated (DPWM) outputs for supporting a wide range of offline, isolated and non-isolated DC/DC topologies
 - 250-ps DPWM pulse-width resolution
 - 4-ns DPWM frequency resolution
 - Adjustable phase shift between DPWM outputs
 - Adjustable dead band between each DPWM pair
- Active-high or -low DPWM polarity
- Up to 2-MHz DPWM switching frequency
- Dedicated high-speed error analog-to-digital converter (EADC)
- Configurable for voltage-mode, average-current-mode and resonant-mode control

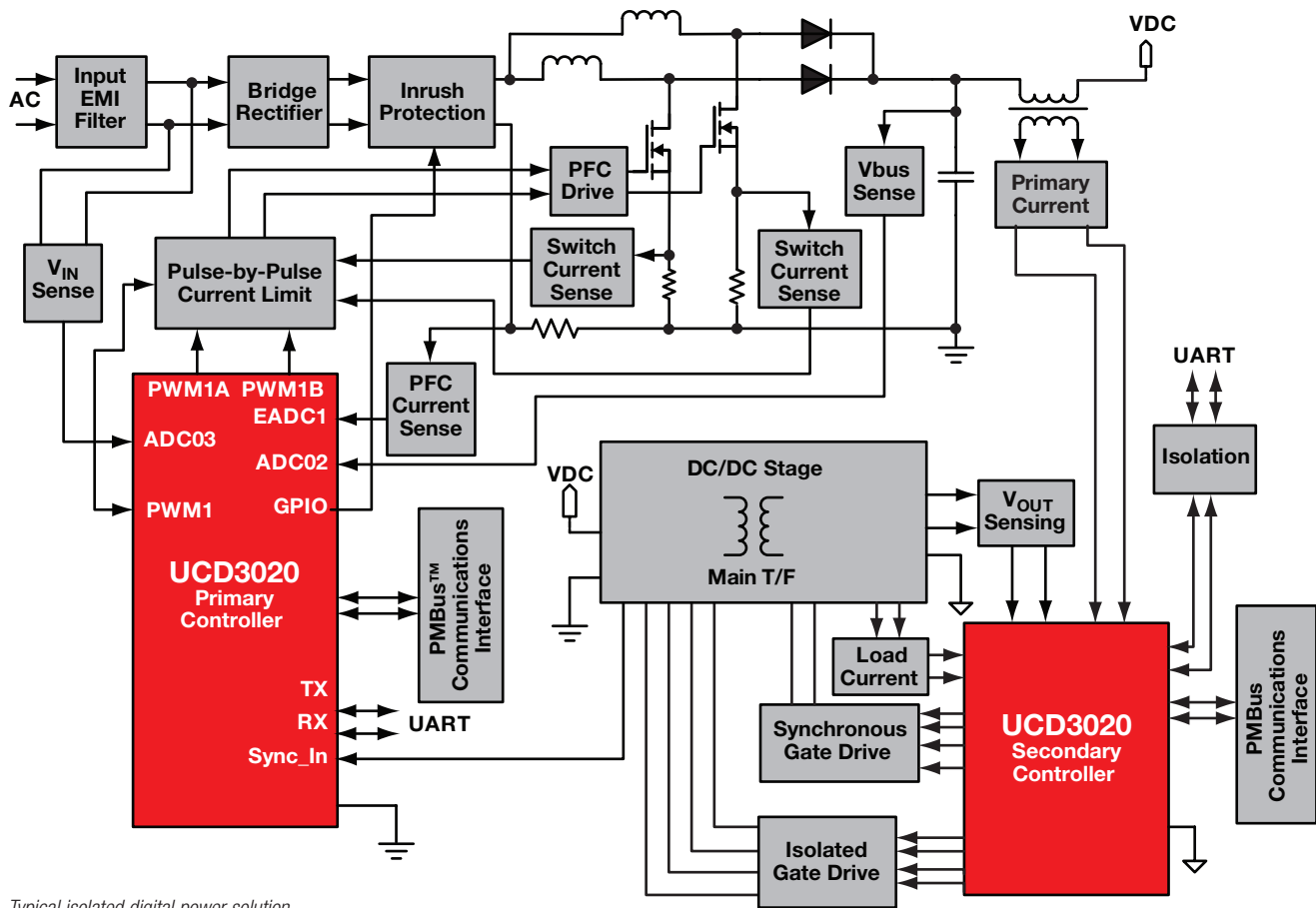

Typical isolated digital power solution.

Isolated Solutions

→ Isolated Power Modules

Design Factors

Plug-in power solutions are board-mounted, completely integrated, DC/DC converters requiring only one or two external components.

Input Voltage (V_{IN}) — Plug-in power solutions are designed to work from industry-standard DC bus voltages.

Output Current (I_{OUT}) — The I_{OUT} of the converter should match the maximum current need of your application.

Output Voltage (V_{OUT}) — Choose an adjustable or fixed V_{OUT} that meets your requirements.

Isolation — Converters with electrical input to output isolation are usually more complex and more expensive.

Features — TurboTrans,[™] SmartSync, adjustable V_{OUT} , remote sense, over-temperature, overcurrent and output inhibit are some of the many features.

Airflow Requirements — The max current of converters often depends on airflow. Safe-operating-area (SOA) curves determine the airflow needs of converters at specific currents.

Protection — Fault protection can include short circuit, overtemperature, overcurrent and overvoltage protection.

Package — Vertical mounting uses the smallest footprint. Surface mount and horizontal through-hole are available in most product series.

Isolated Plug-In Power Modules Family of Products

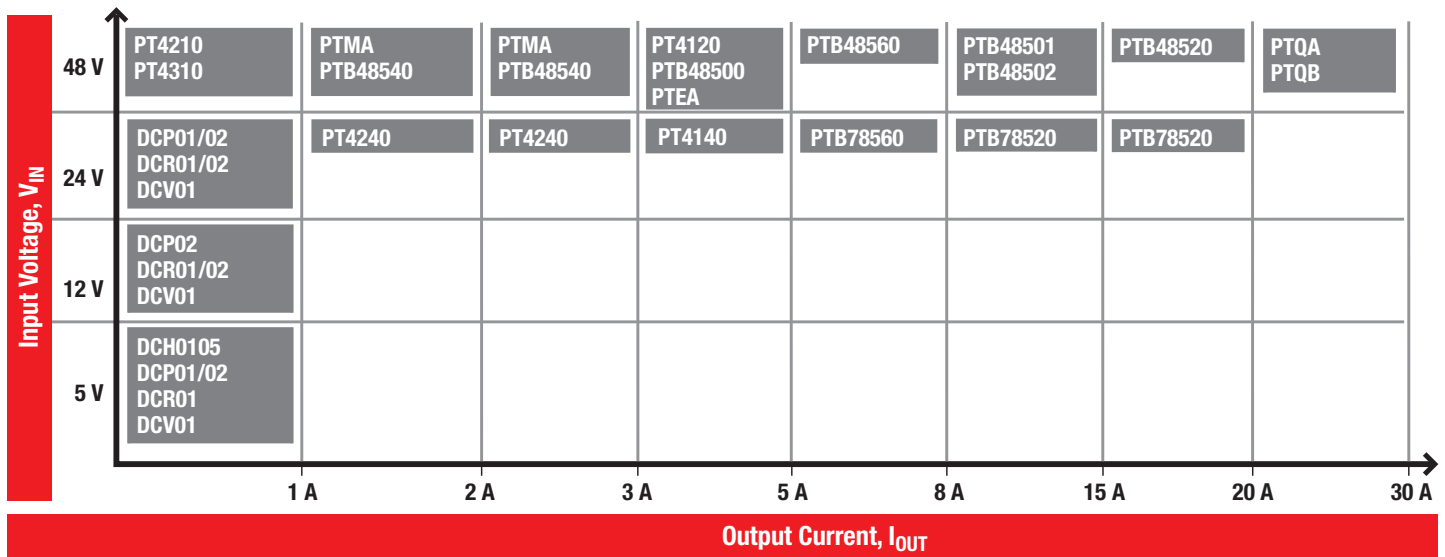

Selection Guide

Device ¹	Input Bus Voltage	Description	P_{OUT} or I_{OUT}	V_O Range (V)	V_O Adj.	Auto-Track [™] Sequencing	Price*
Isolated Single Output							
DCH01_S	5	1-W Unregulated Isolated DC/DC Converter	1 W	5, 12, 15			4.25
DCP01_B	5, 24	1-W Unregulated Isolated DC/DC Converter with Synchronization	1 W	5, 12, 15			5.35
DCP02	5, 12, 24	2-W Unregulated Isolated DC/DC Converter with Synchronization	2 W	3.3, 5, 7, 9, 12, 15			6.95
DCR01	5, 12, 24	1-W Regulated Isolated DC/DC Converter with Synchronization	1 W	3.3, 5			5.95
PT4210	48 V	3- to 7-W 48-V Input Isolated DC/DC Converter	3 to 7 W	3.3 to 12			18.75
PTB48520W	48 V	25-A 48-V Input Isolated POL Converter with Auto-Track I/O	75 W	1.8 to 3.6	✓	✓	62.00
PTB48540A/B/C	48 V	10-W 48-V Input Isolated PoE Module	10 W	3.3, 5, 12	✓		26.00
PTB48560A/B/C	48 V	30-W 48-V Input Isolated POL Converter with Auto-Track I/O	30 W	3.3, 5, 12	✓	✓	25.00
PTB78520W	18 V to 60 V	20-A 18-V to 60-V Input Isolated POL Converter with Track I/O	65 W	1.8 to 3.6	✓	✓	62.00
PTB78560A/B/C	18 V to 60 V	30-W 18-V to 60-V Input Isolated POL Converter with Track I/O	30 W	3.3, 5, 12	✓	✓	25.00
PTEA4	48 V	50-W 48-V Input Isolated DC/DC Converter—Industry Std Footprint	50 W	2.5, 3.3, 12	✓		26.50
PTMA4	48 V	10-W 48-V Input Isolated DC/DC Converter—Industry Std Footprint	10 W	3.3, 5, 12	✓		20.00
PTQA4	48 V	100-W 48-V Input Isolated DC/DC Converter—Industry Std Footprint	100 W	2.5, 3.3, 5	✓		44.00
PTQB4	48 V	200-W 36- to 75-V Input Isolated Bus Converter w Auto-Track	200 W	8		✓	45.00
Isolated Multiple Output							
DCH01_D	5	1-W Unregulated Isolated DC/DC Converter	1 W	±5, ±12, ±15			4.25
DCP01_DB	5, 15, 24	1-W Unregulated Dual Isolated Converter with Synchronization	1 W	±5, ±12, ±15			5.90
DCP02_D	5, 12, 24	2-W Unregulated Dual Isolated Converter with Synchronization	2 W	±5, ±12, ±15			6.95

¹See power.ti.com for a complete product offering.

*Suggested resale price in U.S. dollars in quantities of 1,000.

→ LED Driver Controllers

LED technologies continue to improve and to produce more light while using less power at lower costs. This trend is fueling flexible, creative, cost-effective lighting, backlighting, video, message and signage designs that can be achieved only as a result of these advances in LED technology.

Solid-state LED lighting applications include retrofitted lightbulb replacement, high-bay and street lighting, and fully customized luminaires. Key considerations can include:

- Superior light quality as compared to traditional light sources

- Existing form factor and socket compatibility
- Supply voltage (AC or DC)
- Legacy dimmer compatibility and dimming performance
- High efficiency and long operating life
- Power factor
- Conducted and radiated emissions

Solving these challenges requires a wide variety of LED lighting solutions.

AC/DC LED Drivers – TI offers AC/DC, LED-lighting-driver solutions for dimmable, isolated and non-isolated, highly efficient, power-factor-corrected,

long-life, compact form-factor designs while maintaining compatibility with installed fixtures and dimmers. Over-voltage, over-current and over-temperature protection features ensure that LED lighting products are safer than the traditional bulbs they replace.

DC/DC LED Drivers – TI offers DC/DC lighting-driver solutions with wide input/output operating ranges that can be used in buck, boost, SEPIC and flyback architectures. Small solution sizes facilitate 12- to 24-V retrofitted designs such as MR-16.

Natural PFC LED Lighting Driver Controller

TPS92210

Get samples, datasheets and evaluation modules at: www.ti.com/sc/device/TPS92210

The TPS92210 is a natural power-factor-correction (PFC) LED driver controller with flexible operating modes that allow single-stage PFC. The cascaded MOSFET configuration eliminates the need for external current-sense circuitry and lowers switching losses. The TPS92210 works with TRIAC dimmers and can operate in either DCM or transition mode, yielding high-efficiency and low-EMI solutions.

Applications

- Residential LED lighting drivers:
 - A19 (E27/26, E14), PAR30/38, GU10
- Drivers for wall sconces and pathway and overhead lighting

- Drivers for wall-washing, architectural and display lighting
- Commercial troffers and down lights

Reference Designs

Device	Description
TPS92210EVM-647	TPS92210 evaluation module for 110-VAC TRIAC dimmable lightbulb replacement with natural PFC
TPS92210EVM-613	TPS92210 evaluation module for 220-VAC TRIAC dimmable lightbulb replacement with natural PFC
PMP6001	Non-dimmable LED lighting driver controller (38 V at 350 mA) reference design
PMP6002	TRIAC dimmable 110-V LED lighting driver controller (32 V at 350 mA) reference design
PMP6003	TRIAC dimmable 220-V LED lighting driver controller (32 V at 350 mA) reference design

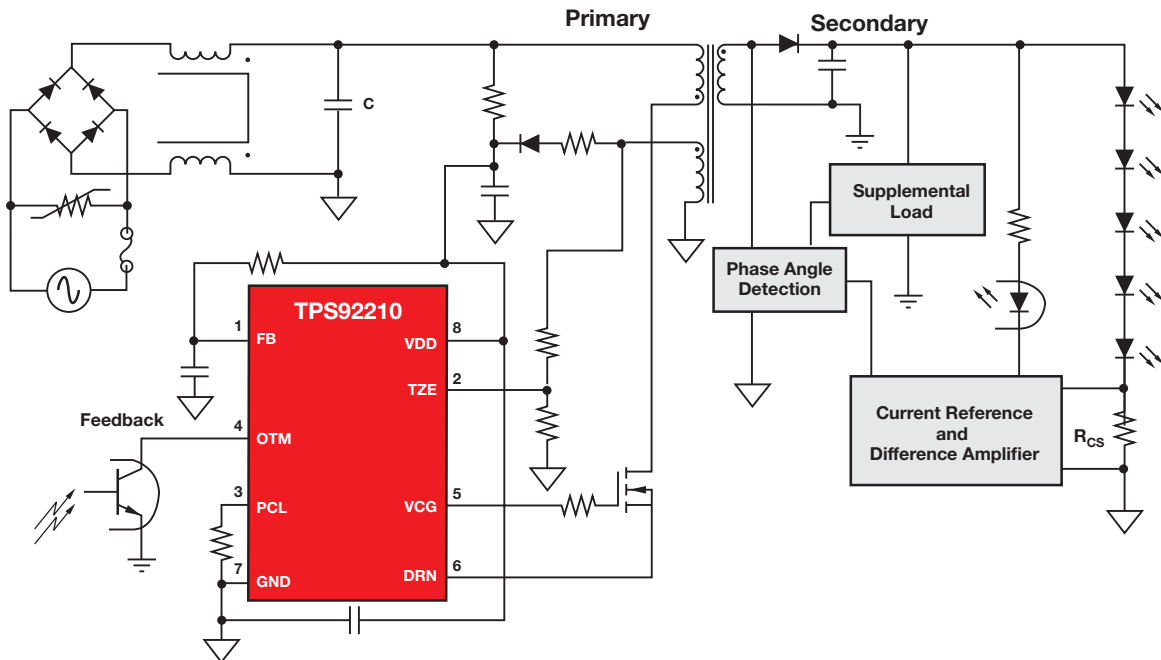

→ LED Driver Controllers

Selection Guide

Device	V _{IN} (min) (V)	V _{IN} (max) (V)	LED Voltage (max) (V)	Switching Frequency (kHz)	DC/DC or AC/DC Control	Isolated Applications	Non-Isolated Applications	Topology	LED Configuration	Dimming	PFC	EVM	Package(s)	Automotive (A) [†]	Price*
TPS54160	3.5	60	57	2500	DC/DC		✓	Buck	Series/Parallel	PWM/Analog		✓	10 HMSOP/QFN	A	2.10
TPS40211	4.5	52	52	1000	DC/DC		✓	Boost/SEPIC	Series/Parallel	PWM/Analog		✓	10 MSOP-PowerPAD™, 10 SON	A	0.99
TPS92001	9	19	Configurable	100	AC/DC	✓	✓	Flyback/Buck	Series/Parallel	TRIAC	✓		8 MSOP, 8 SOIC		0.45
TPS92002	14	19	Configurable	100	AC/DC	✓	✓	Flyback/Buck	Series/Parallel	TRIAC	✓		8 MSOP, 8 SOIC		0.45
TPS92010	6.3	21	Configurable	130	AC/DC	✓	✓	Flyback	Series/Parallel	TRIAC		✓	8 SOIC		0.39
TPS92020	11.5	18	Configurable	350	DC/DC	✓	✓	Half-Bridge	Multi-String Series/Parallel	PWM		✓	8 SOIC		0.80
TPS92210	9	20	Configurable	140	AC/DC	✓	✓	Flyback	Series/Parallel	TRIAC	✓	✓	8 SOIC		0.75
UCC28810	15.4	18	Configurable	140	AC/DC	✓	✓	Flyback/Boost	Series/Parallel	TRIAC	✓	✓	8 SOIC		0.32
UCC28811	12	18	Configurable	140	AC/DC	✓	✓	Flyback/Boost	Series/Parallel	PWM/Analog	✓	✓	8 SOIC		0.32

[†]Devices qualified for Automotive (A) applications are available. Different pricing may apply.

*Suggested resale price in U.S. dollars in quantities of 1,000.

→ LED Video Display Drivers

Design Factors

Dot Correction — Creates uniform LED brightness. Gives the ability to dynamically control the output current.

Grayscale — Provides an enhanced color spectrum per LED equivalent with the number of grayscale steps available.

Output Voltage Monitor — Monitors voltages at constant current output terminals to detect LED failure and short circuit.

LED Open Detection — Indicates a broken or disconnected LED at an output terminal.

Thermal Error Flag — Indicates an overtemperature condition.

Watchdog Timer — Turns output off when scan signal is stopped.

Thermal Shutdown — Turns output off when junction temperature exceeds its limit.

12-Channel, 16-Bit ES-PWM LED Driver with 7-Bit Global Brightness Control

TLC5971

Get samples and datasheets at: www.ti.com/sc/device/TLC5971

- 12 channels allow for 4+ pixels R/G/B LED driven by one device with 60-mA drive capability on each output
- 7-bit global dimming allows fine adjustment between 0 and 100% for each color group
- ES-PWM can control each output's brightness in 65,536 steps for 0 to 100% brightness, providing 281 trillion colors for LED displays

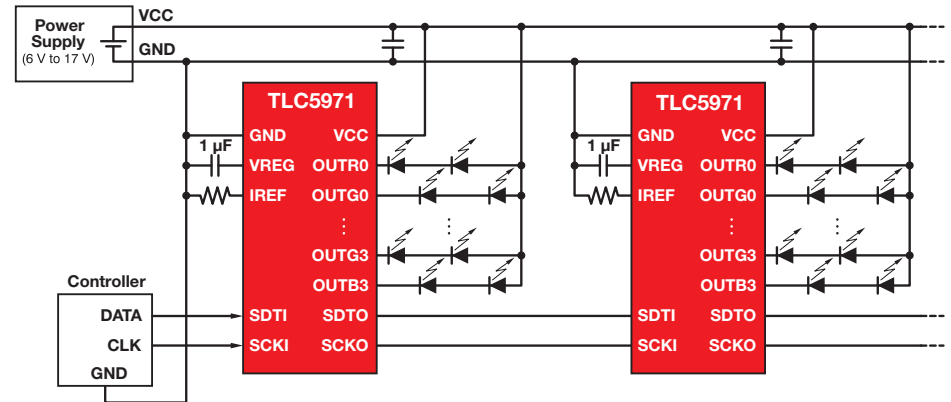

LED Display Drivers Function Guide

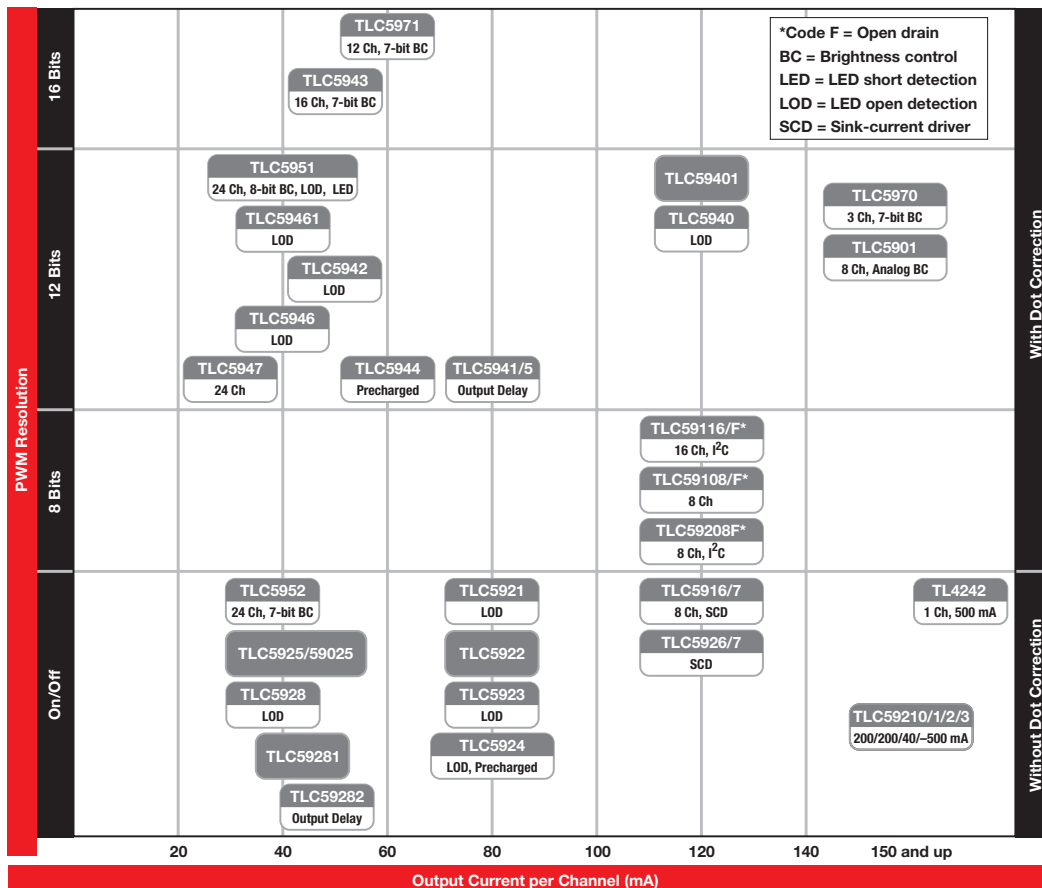

Selection Guide

Device	No. of Chan.	V _{IN} Min (V)	V _{IN} Max (V)	Output Current I _{LED} (mA)	Channel-to-Channel Accuracy (%)	Dev.-to-Dev. Accuracy (%)	Recharged FET	Short Detection	Open Detection	Overtemperature Detection	Brightness Control (Bits)	Dot Correction (Bits)	PWM Grayscale Control (Bits)	Comments	HiRel (H) or Automotive (A) [†]	Price*
TL4242	1	4.5	42	500	—	—		✓	✓	✓					A	0.35
TLC5916	8	3.3	5.5	120	±3 (Max)	±6 (Max)			✓	✓	8				A	0.47
TLC5917	8	3.3	5.5	120	±3 (Max)	±6 (Max)		✓	✓	✓	8				A	0.60
TLC59108	8	3	5.5	100	±3 (Max)	—			✓	✓	8		8	Constant-current output, I ² C		0.80
TLC59108F	8	3	5.5	100	±3 (Max)	—			✓	✓	8		8	Open-drain output, I ² C		0.80
TLC59208F	8	3	5.5	50	±3 (Max)	—			✓	✓	8		8	Open-drain output but changes the I ² C addressing capability, I ² C		0.65
TLC59116	16	3	5.5	100	±6 (Max)	—			✓	✓	8		8	Constant-current output, I ² C		1.45
TLC59116F	16	3	5.5	100	±6 (Max)	—			✓	✓	8		8	Open-drain output, I ² C		1.45
TLC59210	8	3	5.5	200	—	—								Clear function and clock pin for data latch		0.60
TLC59211	8	3	5.5	200	—	—								No clear function and clock pin for data latch		0.55
TLC59212	8	3	5.5	40	—	—										0.48
TLC59213/A	8	3	5.5	-500	—	—								"A" version has 15 ns (non-"A" is 25 ns)		0.70
TLC5921	16	4.5	5.5	80	±1	±4 (Max)			✓	✓						0.85
TLC5922	16	3	5.5	80	±1	±4							7			1.35
TLC5923	16	3	5.5	80	±1	±4			✓	✓			7			1.40
TLC5924	16	3	5.5	80	±1	±4	✓		✓	✓			7			1.50
TLC5925	16	3	5	45	±4 (Max)	±6 (Max)				✓						0.50
TLC59025	16	3	5	45	±4 (Max)	±6 (Max)				✓						0.55
TLC5926	16	3	5.5	120	±6 (Max)	±6 (Max)			✓	✓	8				A	0.60
TLC5927	16	3	5.5	120	±6 (Max)	±6 (Max)		✓	✓	✓	8				A	0.65
TLC5928	16	3	5.5	35	±1	±1			✓	✓						0.50
TLC59281	16	3	5.5	35	±1	±1										0.43
TLC59282	16	3	5.5	45	±0.6	±1								4-channel grouped delay		0.47
TLC5930	12	3	3.6	40	±1	—				✓	6	8	10			3.00
TLC5940	16	3	5.5	120	±1	±2			✓	✓			6	12		1.25
TLC59401	16	3	5.5	120 ¹ /80 ²	±1	+2/-2.7				✓			6	12		1.80
TLC5941	16	3	5.5	80	±1	±2			✓	✓			6	12	A	1.00
TLC5942	16	3	5.5	50	±1.5	±3			✓	✓			7	12		1.10
TLC5943	16	3	5.5	50	±1.5	±3		✓	✓	✓	7		16			1.50
TLC5944	16	3	5.5	60	±1	±3	✓	✓	✓	✓			6	12		1.10
TLC5945	16	3	5.5	80	±1	±2			✓	✓			6	12		1.10
TLC5946	16	3	5.5	40	±1	±2			✓	✓			6	12		1.00
TLC59461	16	3	5.5	40	±1	±2			✓	✓			6	12	No auto-off function	1.05
TLC5947	24	3	5.5	30	±2	±2				✓			12	30-V V _{LED} , internal oscillator		1.40
TLC5951	24	3	5.5	40	±1.5	±3		✓	✓	✓	8	7	12, 10, 8			3.00
TLC5952	24	3	5.5	35	±1	±3		✓	✓	✓	7					2.20
TLC5970	3	10	36	150	±0.5	±3		✓	✓	✓	7	7	12			3.30
TLC5971	12	3	17	60	±1	±1				✓			16	Integrated 3.3-V LDO		1.50

¹ Output current with V_{CC} > 3.6 V.

² Output current with V_{CC} ≤ 3.6 V.

³ TLC5960/TLC59601 output current is limited by external FET.

[†] Devices qualified for HiRel (H) or Automotive (A) applications are available. Different pricing may apply.

*Suggested resale price in U.S. dollars in quantities of 1,000.

→ Overview

TI offers a complete line of devices for powering displays, controlling LED backlighting and generating VCOM and gamma voltages.

Designed to meet your needs for displays of various form factors and technologies, these display-power devices

include LCD bias, level shifters, scan drivers and LCD bias integrated with level shifters.

TI's LED backlighting solutions support LED and WLED drivers with integrated DC/DC and LLC controllers and can be used for different LED backlighting

topologies, dimming types and displays.

TI's gamma-buffer devices support 4 to 12 gamma channels and integrate additional features such as VCOM channels and an I²C communications interface.

→ Display Bias, Level Shifters and Scan Drivers

Multichannel Bias Power for E-Paper Display

TPS65181B

Get more information at: www.ti.com/sc/device/TPS65181B

The TPS65181B is a power management IC that is ideal for powering an electronic paper display (EPD). In addition to the bias supplies required by the display drivers and timing controller, the IC also supports display temperature sensing.

Key Features

- 3- to 6-V input voltage range
- Positive charge-pump driver (VDDH): +20 V at 10 mA
- Negative charge-pump driver (VEE): -20 V at 12 mA

- Two adjustable LDOs
 - +15 V at 120 mA (Default output VPOS)
 - -15 V at 120 mA (Default output VNEG)
 - VPOS + VNEG = ±50 mV
- Adjustable VCOM driver
 - 0.3 to -2.5 V
 - 8-bit resolution
 - 15-A (max) integrated switch
- Integrated temperature sensor
- Integrated power switch
- Packaging: 7x7-mm QFN

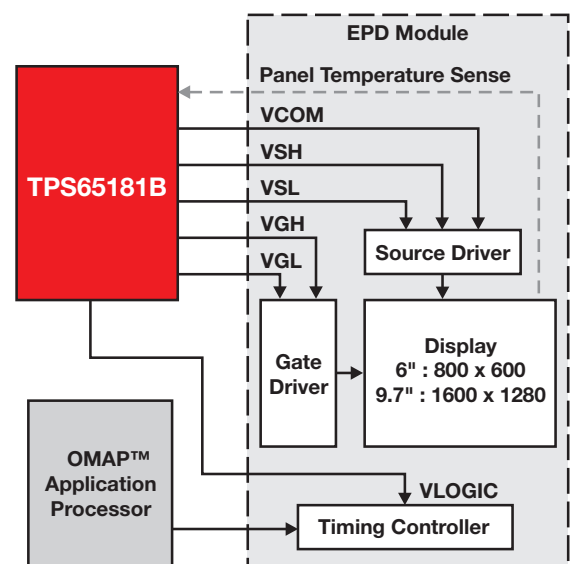

LCD Bias Solution for LCD Panels

TPS65149

Get more information at: www.ti.com/sc/device/TPS65149

The TPS65149 is a highly integrated single-chip IC that is ideal for powering a panel for a monitor or notebook by using ASG/GIP technology. This IC also includes an 8-channel level shifter, a boost converter and a VCOM buffer.

Key Features

- 3- to 6-V input-voltage range
- Boost converter with 4-A switch-current limit
- Boost-converter output voltages up to 18 V
- Temperature-compensated positive-charge-pump controller
- Negative-charge-pump controller
- 8-channel level shifter

- Two panel-discharge signals
- $\overline{\text{XAO}}$ reset signal
- Digitally programmable VCOM buffer
- 56-pin, 7x7-mm QFN package

Applications

- LCD panels using GIP/ASG technology:
 - LCD monitors
 - Small (5-V input) TVs
 - Notebook PCs

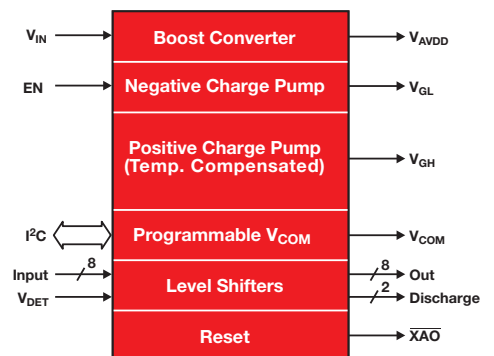

Display Power

→ Display Bias, Level Shifters and Scan Drivers

Selection Guide

Device	V _{IN} (V)	Boost I _{Limit} (min) (A)	Buck I _{Limit} (min) (A)	Features ¹							Price*
				Isolation Switch	V _{GH}	V _{GL}	GVS	V _{Com}	HVS	Other	
Solutions for Large LCDs (TVs)											
TPS61087	5	3.2	—	—	External	External	—	—	—		1.60
TPS65160/A	12	2.8	2	External	Driver	Driver	—	—	—		2.14
TPS65161	12	2.8	2.3	External	Driver	Driver	—	—	—		2.78
TPS65161A	12	3.7	2.3	External	Driver	Driver	—	—	—		2.78
TPS65161B	12	3.7	2.5	External	Driver	Driver	—	—	—		2.78
TPS65162	12	2.8	2.8	Integrated	Driver	Driver	Yes	2 op amps	—		2.45
TPS65163	12	2.8	1.5	External	Controller	Controller	In level shifter	—	—	9-ch level shifter, LCD discharge, reset generator	2.32
TPS65168	12	3.5	2.8	Integrated	Controller	Controller	—	—	—	I ² C programmable, 2 buck, temp. compensation, reset	2.10
TPS65170	12	2.8	1.5	External	Controller	Controller	—	—	—	Reset	1.40

Device	V _{IN} (V)	Boost I _{Limit} (min) (A)	Features ¹								HiRel (H) or Automotive (A) [†]	Price*
			Overvoltage Protection	Isolation Switch	V _{Logic}	V _{GH}	V _{GL}	GVS	V _{Com}	Other		
Solutions for Medium and Small LCDs (Monitors and Notebooks)												
TPS61085	5	2	Yes	—	—	External	External	—	—		A	0.95
TPS61087	5	3.2	Yes	—	—	External	External	—	—			1.60
TPS65100	5	1.6	Yes	—	LDO controller	Integrated	Driver	—	1 buffer		A	1.87
TPS65101	5	1.6	Yes	—	LDO controller	Integrated	Driver	—	1 buffer			1.87
TPS65105	5	0.96	Yes	—	LDO controller	Integrated	Driver	—	1 buffer			1.87
TPS65140	5	1.6	Yes	—	LDO controller	Integrated	Driver	—	—		A	1.71
TPS65141	5	1.6	Yes	—	LDO controller	Integrated	Driver	—	—			1.71
TPS65145	5	0.96	Yes	—	LDO controller	Integrated	Driver	—	—		A	1.71
TPS65146	2.5 to 6	2	Yes	—	LDO	Driver	External	Yes	1 buffer	LDO for gamma, reset (XAO), LCD discharge		1.80
TPS65148	2.5 to 6	4	Yes	External	LDO	External	External	Yes	1 buffer	LDO for gamma, reset (XAO), LCD discharge		2.10
TPS65149	3 to 6	4.0	Yes	External	—	Controller	Controller	—	Programmable, no buffer	Level shifters, reset		1.90
TPS65150	5	2	Yes	External	—	Driver	Driver	Yes	1 buffer			1.92
TPS65165	5	4.4	Yes	—	—	Integrated	Driver	Yes	2 op amps, 1 buffer			1.80

¹V_{GH} = Positive LCD rail voltage, V_{GL} = Negative LCD rail voltage, GVS = Gate-voltage shaping for V_{GH}, V_{Com} = LCD V_{Com} voltage source, and HVS = High-voltage stress-test control.

[†]Devices qualified for HiRel (H) or Automotive (A) applications are available. Different pricing may apply.

*Suggested resale price in U.S. dollars in quantities of 1,000.

New devices are listed in bold red.

Device	Description	Number of Channels			V _{GH1} (max) (V)	V _{GH2} (max) (V)	V _{GL} (max) (V)	V _{Com}	GVS/GPM	Charge Sharing	Other	Package	Price*
		Clock	Discharge	Additional									
LCD Support IC Solutions (Scan Drivers/Level Shifters)													
TPS65190	10-channel level shifter for LCD displays w/V _{Com} op amp	8	—	2	38	38	-13	Op amp 200 mA	—	—		QFN-28	1.00
TPS65192	10-channel level shifter for LCD displays w/GPM	7	1	2	38	38	-15	—	Yes	—	LCD discharge	QFN-28	1.40
TPS65194	13-channel level shifter for LCD displays w/V _{Com} op amp	6	1	6	38	38	-15	Op amp 200 mA	—	—	State machine	QFN-24	0.80
TPS65191	7-channel level shifter for LCD displays (triple channel scan driver)	7	—	—	35	—	-28	—	—	Yes		QFN-32	1.00
TPS65193	5-channel level shifter for LCD displays (dual channel scan driver)	5	—	—	35	—	-28	—	—	Yes		QFN-24	0.80

*Suggested resale price in U.S. dollars in quantities of 1,000.

New devices are listed in bold red.

Display Power

→ Display Bias, Level Shifters and Scan Drivers

Selection Guide (Continued)

Device ¹	V _{IN} (V)	LDO 1	LDO 2	Charge Pump 1	Charge Pump 2	Application	Temperature Acquisition	Communication Interface	I ² C Read	Fault Recovery	V _{Com} Adjust	Price*
Solutions for E-Readers												
TPS65180B	3 to 6	15 V, 120 mA	-15 V, 120 mA	22 V, 10 mA	-20 V, 12 mA	Single host systems w/ integrated or SW timing controller (OMAP™); Epson S1D113522 (ISIS)	Must be triggered by host through I ² C	I ² C; GPIO (WAKEUP, PWRx); Interrupt (INT)	Standard I ² C interface. FIX_RD_PTR function is not available.	INT register must be read before rails can be reenabled if after a fault.	By default under register control (internal adjustment).	2.35
TPS65181B	3 to 6	15 V, 120 mA	-15 V, 120 mA	22 V, 10 mA	-20 V, 12 mA	Epson S1D13522 (ISIS); Epson S1D13521 (Broadsheet) w/internal VCOM adjust	Automatically triggers every 60 s	I ² C; GPIO (WAKEUP, PWRx); Interrupt (INT)	Standard I ² C interface. With FIX_RD_PTR bit set, device only returns data from register 0x00h (temp reading). To read other reg's, FIX_RD_PTR bit must be set to 0 (default).	INT bits get reset automatically when faults clear. No need to read INT register.	By default external adjustment is enabled. Internal adjustment is supported.	2.35
TPS65182B	3 to 6	15 V, 120 mA	-15 V, 120 mA	22 V, 10 mA	-20 V, 12 mA	Epson S1D13521 (Broadsheet) w/internal VCOM adjust	Automatically triggers every 60 s	I ² C; GPIO (WAKEUP, PWRx)	Only temperature data is available through I ² C interface. Register address doesn't need to be sent to read temperature data (Broadsheet compatible).	Power rails can be re-enabled after fault has been resolved.	Only external adjustment supported.	2.35

¹See datasheets for more specifications.

*Suggested resale price in U.S. dollars in quantities of 1,000.

Device	Description	Features	V _{IN}		Frequency	AV _{DD} I _{Limit}	AV _{DD}	Isolation Switch	V _{Logic1} I _{Limit}	V _{Logic1}	V _{GH} (I _{GH})	V _{GL} (I _{GL})	Other	Package	Price*
			(min) (V)	(max) (V)		(min) (mA)	(max) (V)		(min) (A)	(min) (V)					
LCD SFF/MFF — OLED Solutions (<5 V)															
TPS65120	4-ch single inductor multiple outputs (SIMO) bias IC w/ fixed 3.3-V V _{Logic}	Small form factor	2.5	5.5	4 MHz	7.5/25	5.6	Internal	LDO controller	Fixed 3.3	Integrated 20 V max. (6 mA)	Inverter -18 V max. (6 mA)	—	QFN-16	0.95
TPS65121	4-ch single inductor multiple outputs (SIMO) bias IC w/ fixed 1.8-V V _{Logic}	Small form factor	2.5	5.5	4 MHz	7.5/25	5.6	Internal	LDO controller	Fixed 1.8	Integrated 20 V max. (6 mA)	Inverter -18 V max. (6 mA)	—	QFN-16	0.95
TPS65123	3-ch single inductor multiple outputs (SIMO) bias IC	Small form factor	2.5	5.5	4 MHz	7.5/25	5.6	Internal	—	—	Integrated 20 V max. (6 mA)	Inverter -18 V max. (6 mA)	—	QFN-16	0.95
TPS65124	3-ch single inductor multiple outputs (SIMO) bias IC w/ adjustable sequencing	Small form factor	2.5	5.5	4 MHz	7.5/25	5.6	Internal	—	—	Integrated 20 V max. (6 mA)	Inverter -18 V max. (6 mA)	Adjustable sequencing	QFN-16	0.95
TPS65130	Dual positive and negative outputs (700 mA)	OLED, CCD sensor	2.7	5.5	1.4 MHz	—	—	External	—	—	Boost 15 V max. (0.7 A I _{Limit})	Inverter -15 V max. (0.7 A I _{Limit})	—	QFN-24	1.70
TPS65131	Dual positive and negative outputs (1800 mA)	OLED, CCD sensor	2.7	5.5	1.4 MHz	—	—	External	—	—	Boost 15 V max. (1.8 A I _{Limit})	Inverter -15 V max. (1.8 A I _{Limit})	—	QFN-24	2.20
TPS65136	Single inductor multiple outputs (SIMO) for positive and negative output	AMOLED	2.3	5.5	40 kHz to 1 MHz	—	—	Internal	—	—	Boost fixed 4.6 V (80 mA)	Inverter -6 V max. (80 mA)	—	QFN-16	1.20
TPS65137	Dual positive and negative output w/digital V _{neg} adjustment	AMOLED	2.3	5.5	1.6 MHz	—	—	Internal	—	—	Boost fixed 4.6 V (200 mA)	Inverter -5.2 V max. (200 mA)	Digital adjustment for V _{GL}	QFN-10	0.85

*Suggested resale price in U.S. dollars in quantities of 1,000.

New devices are listed in bold red.

Gamma Buffers

Channels	0-V _{Com} Channels	1-V _{Com} Channels	2-V _{Com} Channels
24			BUF22821
20		BUF01901	
18			BUF20820, BUF16821, BUF20800
14			BUF16820
12	BUF12800		
10		BUF11702/5	
9		BUF08821	

Channels	0-V _{Com} Channels	1-V _{Com} Channels	2-V _{Com} Channels
8		BUF08630	
7		BUF08800	
6	BUF06704	BUF07702/3/4	
5		BUF06703	
4		BUF05703/4	
1		BUF01900	

New devices are listed in bold red.

Display Power

→ LED Backlighting Drivers

Design Factors

Dot Correction — Creates uniform LED brightness. Gives the ability to dynamically control the output current.

Grayscale — Provides an enhanced color spectrum per LED equivalent with the number of grayscale steps available.

Output Voltage Monitor — Monitors voltages at constant current output terminals to detect LED failure and short circuit.

LED Open Detection — Indicates a broken or disconnected LED at an output terminal.

Thermal Error Flag — Indicates an overtemperature condition.

Watchdog Timer — Turns output off when scan signal is stopped.

Thermal Shutdown — Turns output off when junction temperature exceeds its limit.

TI LED Driver Configurations

32" LCD TV

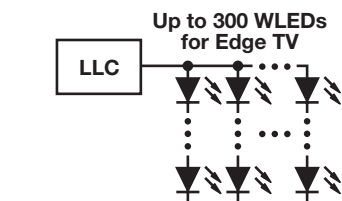
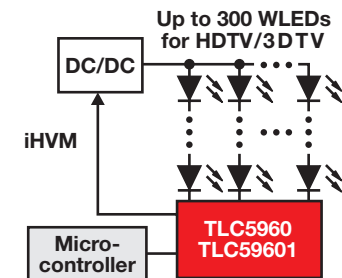
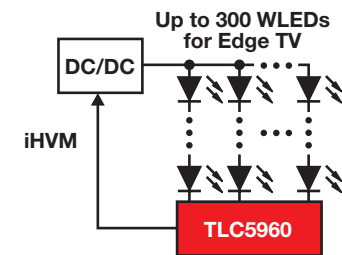
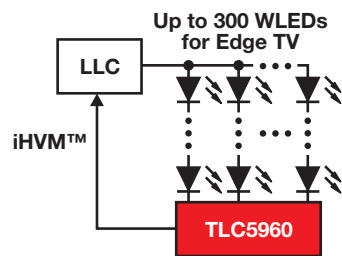

15" to 26" LCD Monitor

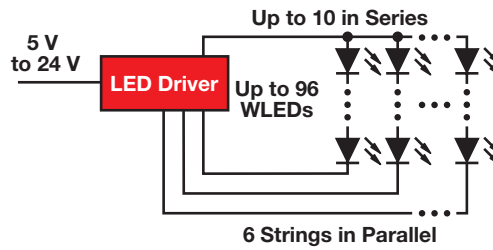

4" to 6" LCD

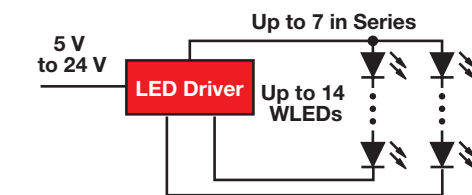

3" to 5" LCD

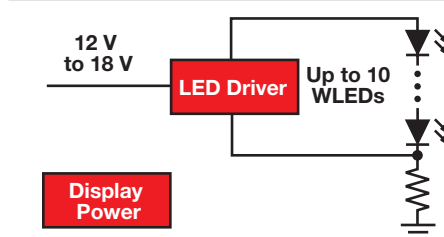

7" to 15" LCD

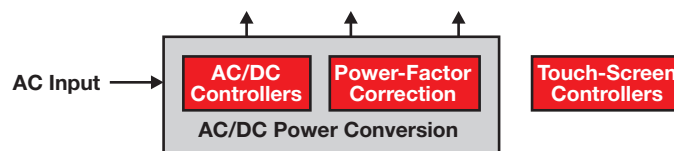
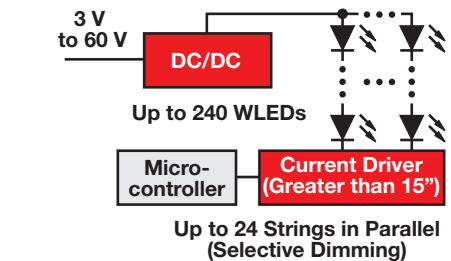
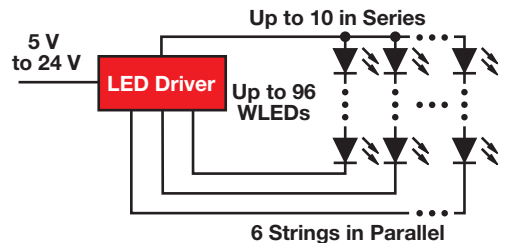
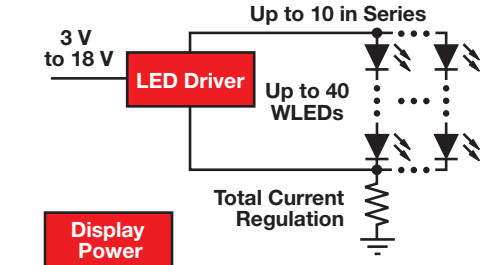

→ LED Backlighting Drivers

8-Channel LED Driver with Intelligent Headroom Voltage Monitor (iHVM™)

TLC5960

Get samples and datasheets at: www.ti.com/sc/device/TLC5960

- Four iHVM™ feedback outputs automatically compensate the LED V_f variance to temperature and current changes, allowing a power savings of ~20% and easy thermal design
- Fast and easy PWM dimming of 250 kHz allows designs with mega contrast ratio
- Full protection: Diagnostic functions and power-on-reset circuitry give a very robust design in case of system failure

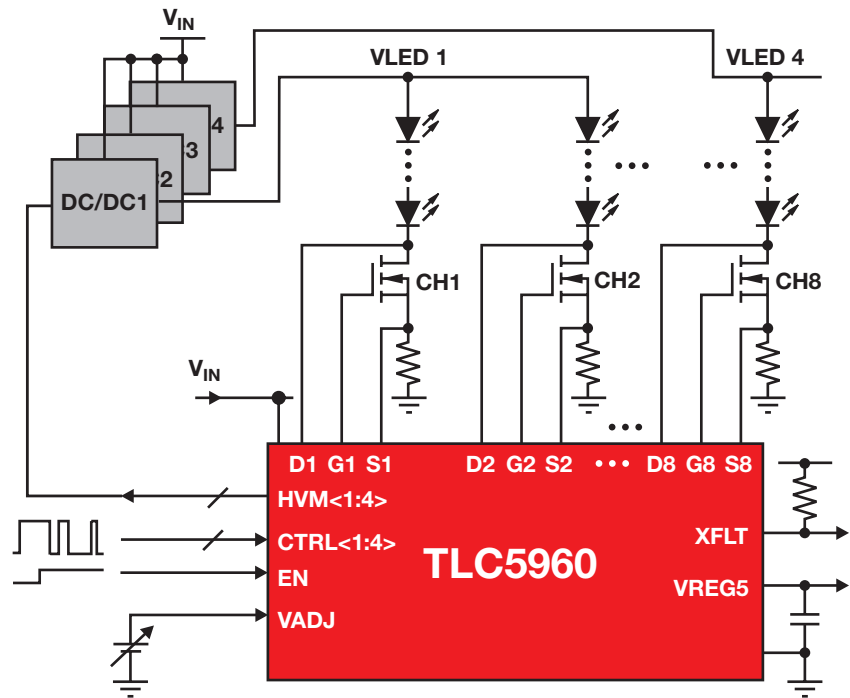

iHVM™ with LLC's High Efficiency and Low Cost

TLC596x + UCC25600

Get samples, datasheets, evaluation modules and app reports at: www.ti.com/sc/device/TLC5960 or www.ti.com/sc/device/UCC25600

The TLC5960 is an eight-channel LED driver with 250-kHz dimming capability. This is the industry's first LED driver that perfectly fits into systems with direct LED drivers that must provide control back to isolated stages such

as flyback and LLC. The secondary-feedback controlling mechanism of the innovative iHVM™ technology optimizes LED strings' forward-voltage variances automatically. An LLC multiple-output configuration can be

used to regulate the output voltage of the iHVM. The iHVM is flexible enough to utilize a normal DC/DC boost LED power-supply configuration.

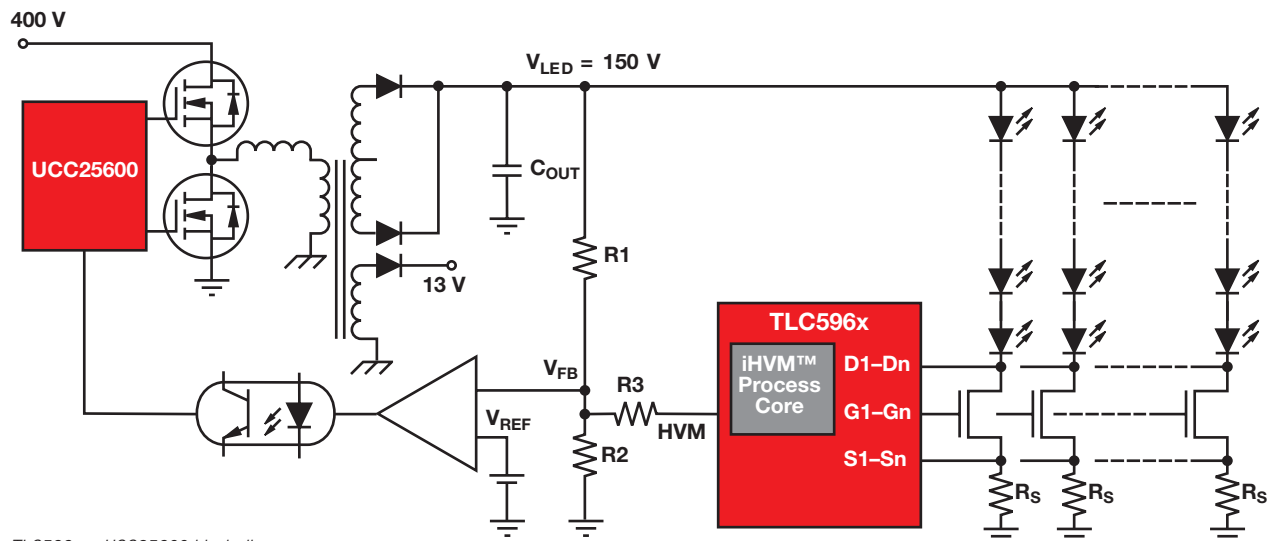

TLC596x + UCC25600 block diagram.

Display Power

LED Backlighting Drivers

Selection Guide

Device	V _{IN} (V)	Synchronous	Type	Number of LEDs ¹	OLED Capable	LED Configuration	Switch Current Limit (typ) (mA)	Current Regulation	Overvoltage Protection (min) (V)	Output Capacitor	Load-Disconnect During Shutdown	Dimming ²	Peak Efficiency ³ (%)	Quiescent Current (typ) (mA)	Shutdown Current (typ) (µA)	Package(s)	HiRel (H) or Automotive (A) [†]	Price*
WLED Drivers																		
TPS61041	1.8 to 6.0		Inductive	4		Series	250		No	1 µF		Yes	85	0.028	0.1	SOT-23	A	0.65
TPS61040	1.8 to 6.0		Inductive	6		Series	400		No	1 µF		Yes	86	0.028	0.1	SOT-23	A	0.65
TPS61043	1.8 to 6.0		Inductive	4		Series	400	✓	17	100 nF	✓	Yes	85	0.038	0.1	QFN-8		0.71
TPS61042	1.8 to 6.0		Inductive	6		Series	500	✓	28	100 nF	✓	Yes	85	0.038	0.1	QFN-8		0.75
TPS61045	1.8 to 6.0		Inductive	6	✓	Series	500	✓	28	100 nF	✓	Yes	85	0.038	0.1	QFN-8		0.90
TPS61140	2.5 to 6.0	✓	Inductive	4 + 1 OLED	✓	2 Series	2 x 550	✓	28	—		1-pin	82	2	1.5	QFN-10		1.16
TPS61150A	2.5 to 6.0	✓	Inductive	Up to 2 x 6		2 Series	2 x 550	✓	28	—		1-pin	83	2	1.9	QFN-10		1.16
TPS61166	2.5 to 6.0	✓	Inductive	5		Series	1100 ⁴	✓	19	4.7 µF	✓	Yes	—	1.5	1	QFN-10		1.35
TPS61160	2.7 to 18		Inductive	6		Series	700	✓	26	1 µF		1-pin	90	1.8	1	QFN-6		0.72
TPS61160A	2.7 to 18		Inductive	6		Series	700	✓	26	1 µF		Yes	90	1.8	1	QFN-6		0.72
TPS61161	2.7 to 18		Inductive	10		Series	700	✓	38	1 µF		1-pin	90	1.8	1	QFN-6	A	0.76
TPS61161A	2.7 to 18		Inductive	10		Series	700	✓	38	1 µF		Yes	90	1.8	1	QFN-6		0.76
TPS61165	3.0 to 18		Inductive	10 to 40		Series	1200	✓	38	1 µF		1-pin	90	2.3	1	QFN-6		1.10
TPS61060	2.7 to 6.0	✓	Inductive	3		Series	400	✓	14	220 nF		Yes	83	—	1	QFN-8/WCSP-8		0.85
TPS61061	2.7 to 6.0	✓	Inductive	4		Series	400	✓	18	220 nF		Yes	82	—	1	QFN-8/WCSP-8		0.90
TPS61062	2.7 to 6.0	✓	Inductive	5		Series	400	✓	22	220 nF		Yes	81	—	1	QFN-8/WCSP-8		0.97
REG71050	3.2 to 5.5	—	Charge pump	3		Parallel	—	—	—	2.2 µF	—	No	92	0.065	0.01	SOT-23		0.55
TPS60230/1	2.7 to 6.5	—	Charge pump	5, 3		Parallel	—	✓	—	1 µF	—	Yes	85	0.200	0.1	QFN-16		0.55
TPS60250/5	2.7 to 6.0	—	Charge pump	7		Parallel	—	✓	—	4.7 µF	—	i ² C	—	6.7	1.3	QFN-16		0.90
TPS60251	2.7 to 6.0	—	Charge pump	7 + Aux		Parallel	—	✓	—	4.7 µF	—	i ² C	—	6.7	1.3	QFN-24		0.90
TPS75103/5	2.7 to 5.5	—	LDO	2 or 4		Parallel	—	✓	—	—	—	Yes	—	0.18	0.1	WCSP-9		0.65
TCA6507	1.65 to 3.6	—	Parallel	7		Parallel	—	—	—	—	—	—	—	—	—	WCSP-12/QFN-12		0.80
TPS61183	4.5 to 24		Inductive	10 x 6		6 Series	2000	✓	38	10 µF		Yes	95	4	11	QFN-20		1.85
TPS61185	4.2 to 24		Inductive	10 x 8		8 Series	2000	✓	38	10 µF		Yes	94	<3	<10	QFN-24		1.80
TPS61195	4.5 to 21		Inductive	8 x 10		10 Series	3500	✓	50	10 µF		Yes	95	<3	<10	QFN-28		1.95

¹More LEDs can be driven in parallel string configuration.

²May be via ENABLE pin, CONTROL pin or analog feedback network.

³Depends on LED current, input voltage, number of LEDs, ILED pin.

⁴Output current is limited to 300 mA.

[†]Devices qualified for HiRel (H) or Automotive (A) applications are available. Different pricing may apply.

*Suggested resale price in U.S. dollars in quantities of 1,000.

New devices are listed in bold red.

Device	No. of Chan.	V _{IN} Min (V)	V _{IN} Max (V)	Output Current I _{LED} (mA)	Channel-to-Channel Accuracy (%)	Dev.-to-Dev. Accuracy (%)	Short Detection	Open Detection	Overtemperature Detection	Comments	Price*
TLC5960	8	10	28	350 ¹	0.3	±1	✓	✓	✓	4 iHVM™ outputs, 4 PWM controls, external FET	1.30
TLC59601	8	10	28	350 ¹	0.3	±1	✓	✓	✓	1 iHVM output, 8 PWM controls, external FET	1.40

¹TLC5960/TLC59601 output current is limited by external FET.

*Suggested resale price in U.S. dollars in quantities of 1,000.

New devices are listed in bold red.

Device	Typical Power Level	Topology	Maximum Practical Frequency (kHz)	Start-Up Current (µA)	Operating Current (mA)	Supply Voltage (V)	UVLO: On/Off (V)	Max Duty Cycle (%)	Soft Start	Output Drive (Sink/Source) (A)	Package(s)	Price*
UCC25600	200 W to 1 kW	Half-bridge	350	100	7.5	11.5 to 18	11.1/8.9	Variable	✓	0.4/0.8	8-SOIC	0.80
UCC25710	80 W to 500 W	Half-bridge	300	—	—	12 to 18	10/8.5	—	✓	0.4/0.8	20-SOIC	1.50

Note: UCC2xxx devices are extended temperature-range versions of the UCC3xxx devices.

*Suggested resale price in U.S. dollars in quantities of 1,000.

New devices are listed in bold red.

Battery Management Products

→ Overview

Design Factors

Battery Chemistry — Each battery chemistry has different operating characteristics, such as discharge profiles and self-discharge rate. TI gas gauge ICs are developed by chemistry to account for these differences to accurately display remaining energy in the battery. Also, each battery chemistry has unique requirements for its charge algorithm, which is critical for maximizing its capacity, cycle life and safety.

Charge-Control Topology — A simple linear topology works well in applications with low-power (e.g., one- or two-cell Li-Ion) battery packs that are charged at less than 1 A. A switch-mode topology is ideally suited for fast charging from USB ports or for large battery packs that require charge rates >1 A. The switch-mode conversion minimizes heat generation during charging. A wireless power topology uses shared magnetic fields to provide the benefit of contactless power transfer. Wireless charging provides an additional battery-charging option for

portable devices or as a replacement for other 5-V charging sources.

Input Voltage — Wide input-voltage range of the IC and input overvoltage protection offer maximum safety and allow use of low-cost unregulated wall adapters.

Number of Series Cells — A battery pack is constructed from a string of series and parallel cells. Each series cell, or group of parallel cells, requires protection from overcharge, overdischarge and short-circuit conditions.

Battery Management

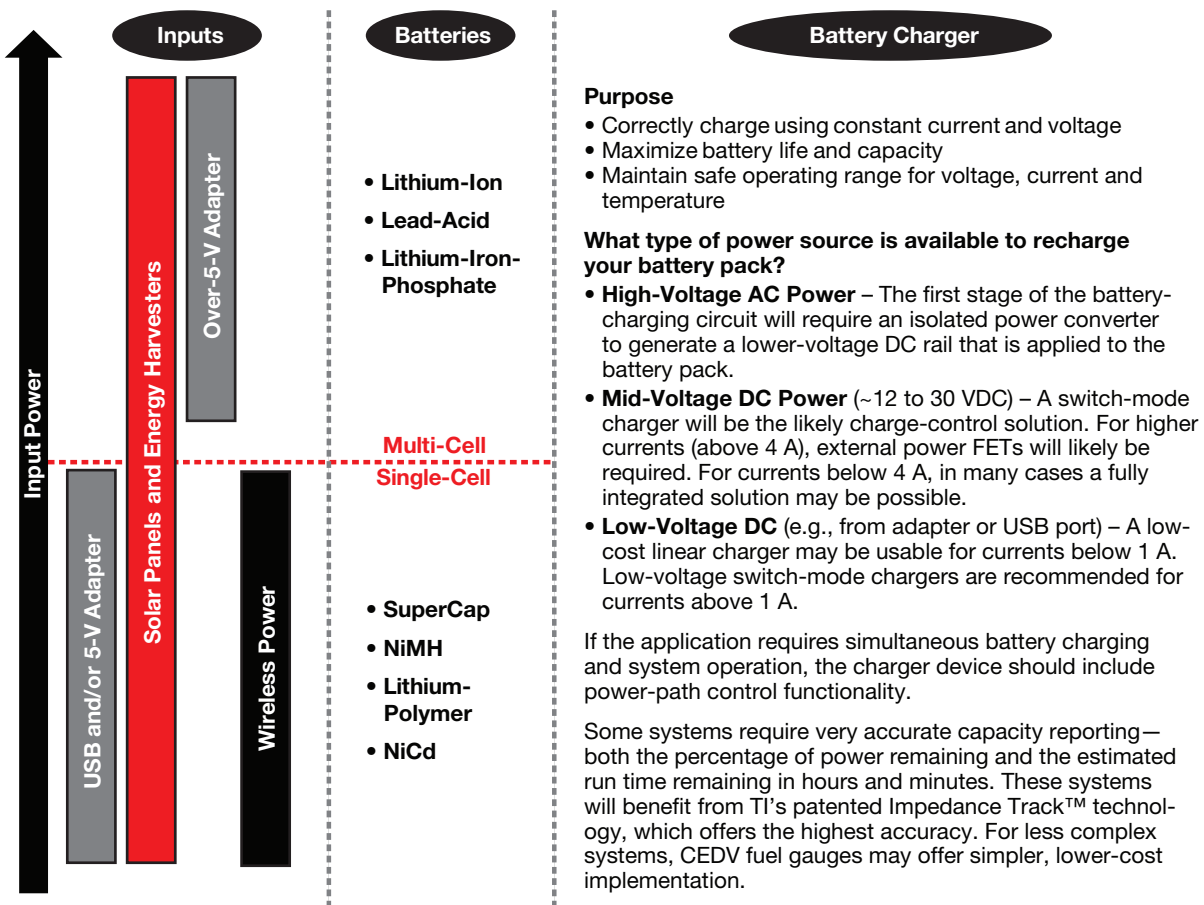

Battery Management Products

➔ Charger Front-End Protection

Li+ Charger Front-End Protection IC

bq24314

Get samples, datasheets, evaluation modules and app reports at: www.ti.com/sc/device/bq24314

Charger front-end protection ICs provide protection from input overvoltage, input overcurrent and battery overvoltage conditions. The tri-level protection offers maximum safety when charging a hand-held device. With integrated FET, the protection IC comes in 2x2-mm and 3x4-mm SON packages.

Features

- 30-V maximum input
- Up to 1.5-A input current
- Thermal shutdown
- Enable input

- Provides protection for three variables:
 - Input overvoltage (rapid response <1 μs)
 - User-programmable overcurrent with current limiting
 - Battery overvoltage

Applications

- Mobile phones and smart phones
- Portable navigation devices
- MP3 Players
- Low-power handheld devices
- Bluetooth® headsets

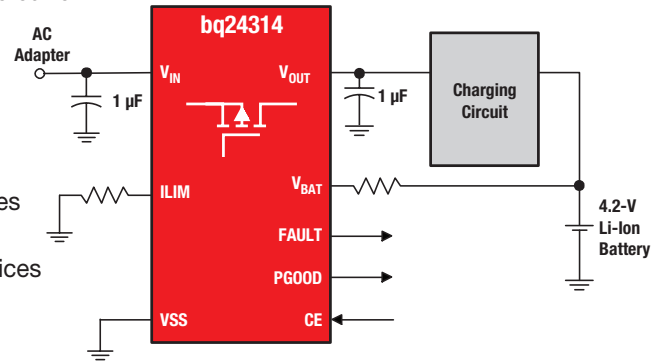

Selection Guide

Device	V _{IN} Max (V)	OVP (V)	OCP	Battery OVP (V)	LDO Output (V)	Max Operating Current (μA)	Package(s)	EVM	Comments	Price*
bq24300/4/5	30	10.5	Fixed 300 mA	4.35	5.5/4.5/5.0	400/500/500	8-QFN/SO8	✓	Reverse polarity protection	0.55
bq24308	30	6.3	Fixed 700 mA or Prog. <1.5 A	4.35	5	500	8-QFN/SO8	✓	Reverse polarity protection	0.55
bq24314/A	30	5.85	Prog. <1.5 A	4.35	—	600	8/12-QFN/SO8	✓	Fault indication	0.55
bq24315	30	5.85	Prog. <1.5 A	4.35	5.5	600	8-QFN/SO8	✓	Fault indication	0.55
bq24316	30	6.8	Prog. <1.5 A	4.35	—	600	8/12-QFN/SO8	✓	Fault indication	0.55
bq24380	30	6.3	No OCP	4.35	5.5	250	8-QFN/SO8	✓	Fault indication	0.55
bq24381	30	7.1	No OCP	4.35	5	300	8-QFN/SO8	✓	Fault indication	0.55
bq24382	30	10.5	No OCP	4.35	5	300	8-QFN/SO8	✓	Fault indication	0.55
bq24350/1/2	30	6.17/10.5/7.1	Fixed 1.2 A	4.35	5.5/6.38/5.5	500	8-QFN/SO8	✓	Integrated charge FET	0.65

*Suggested resale price in U.S. dollars in quantities of 1,000.

New devices are listed in bold red.

➔ Battery Charge Management

Li-Ion Charger with Automatic USB Detection

bq24050

Get samples, datasheets, evaluation modules and app reports at: www.ti.com/sc/device/bq24050

The bq24050 can intelligently detect if a power source is a dedicated power adapter or a USB port. This feature allows a system to immediately start fast charging if a USB transceiver is not available because of a discharged battery.

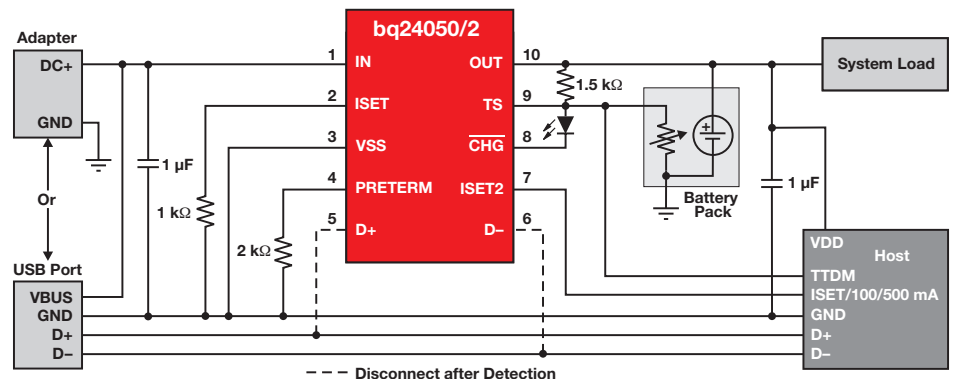

Battery Management Products

→ Battery Charge Management

Stand-Alone Synchronous Switch-Mode Li-Ion or Li-Polymer Battery Charger

bq24610

Get samples, datasheets, evaluation modules and app reports at: www.ti.com/sc/device/bq24610

The bq24610 is a highly integrated Li-Ion or Li-Polymer switch-mode battery charger. It offers a constant-frequency synchronous switching PWM controller with highly accurate regulation of charge current and voltage. It also provides charge preconditioning, termination, adapter current regulation and charge-status monitoring.

Key Features

- 600-kHz NMOS/NMOS synchronous buck converter
- Stand-alone charger support for Li-Ion or Li-Polymer battery
- Supports up to six battery cells (bq24610) and has an input operating range of 5-V to 28-V V_{CC}
- Up to 10-A charge current and adapter current

Applications

- Netbooks, mobile Internet devices and ultra-mobile PCs
- PDAs
- Handheld terminals
- Industrial and medical equipment

Selection Guide

Device	Number of Cells	Control Topology	Integrated Power FET	V_{IN} Max (V)	Primary Charge Termination Method	Safety Timer	Temp Monitor	Packaging: QFN/MLP	EVM	Comments	Price*
Multi-Cell Switch-Mode Stand-Alone Battery Chargers with External FETs (Controllers) — Lithium-Ion (except where noted)											
bq24600/10/16/18	1 to 6	Switching	No	32	Min current	Yes	Yes	16/24	✓	'16 supports JEITA, '18 supports 4.7 V_{IN} min	Multiple
bq24617	1 to 5	Switching	No	26	Min current	Yes	Yes		✓		2.90
bq24620/30	1 to 7	Switching	No	33	Min current	Yes	No	16/24	✓	Solely for LiFePO ₄ , bq24630 supports system power selector	2.90
bq24640	1 to 9	Switching	No	33	SuperCap-specific	No	Yes	16	✓	Supports SuperCap	3.75
bq24650	1 to 6	Switching	No	33	Min current	Yes	Yes	16	✓	Solar charger for Li-Ion/polymer, LiFePO ₄ , lead acid chemistries	2.85

*Suggested resale price in U.S. dollars in quantities of 1,000.

New devices are listed in **bold red**.

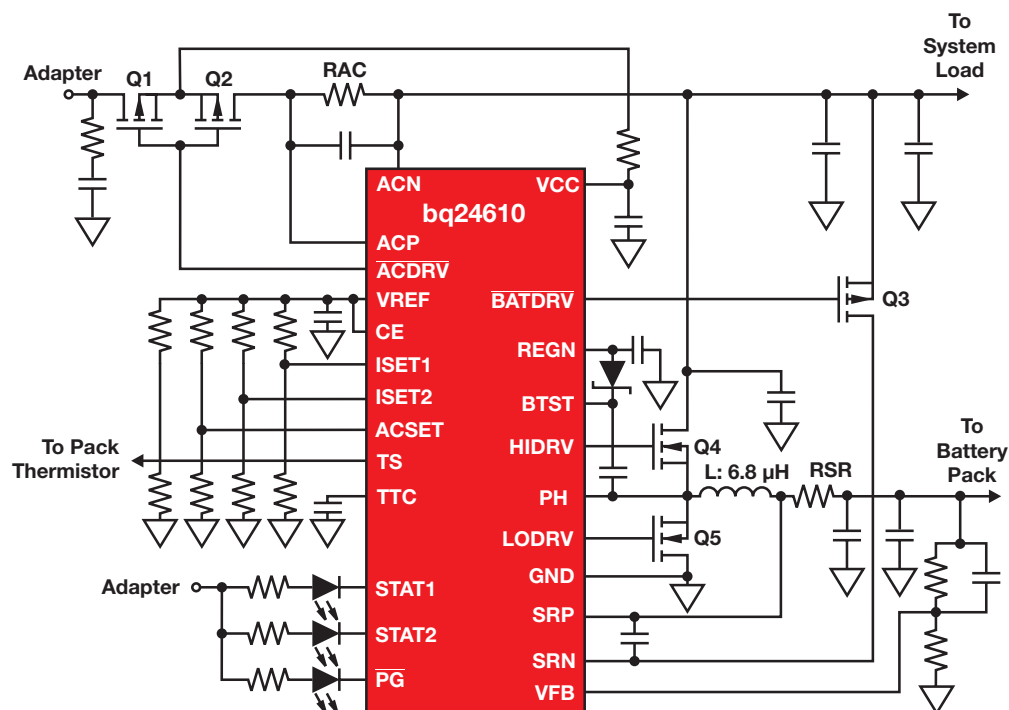

Battery Management Products

→ Battery Charge Management

Switch-Mode Li-Ion and Li-Polymer Stand-Alone Battery Charger

bq24170

Get samples, datasheets, evaluation modules and app reports at: www.ti.com/sc/device/bq24170

The bq24170 is a highly integrated stand-alone Li-Ion or Li-Polymer switch-mode battery charger with two integrated n-channel power MOSFETs. It offers a constant-frequency synchronous PWM controller with highly accurate regulation of input current, charge current and voltage. It closely monitors the battery-pack temperature to allow charging only in a preset temperature window. It

also provides battery detection, preconditioning, charge termination and charge-status monitoring.

Key Features

- 1.6-MHz synchronous switch-mode charger with 4-A integrated n-channel MOSFETs
- Up to 94% efficiency
- 4.5-V to 17-V input operating range

- Battery charge voltage: 1, 2 or 3 cells with 4.2 V per cell

Applications

- Tablet PCs
- Netbooks and ultra-mobile computers
- Portable data-capture terminals
- Portable printers
- Medical-diagnostics equipment
- Battery-bay chargers
- Battery back-up systems

Selection Guide

Device	Number of Cells	Control Topology	Integrated Power FET	Charge Current Internal FET	V _{IN} Max (V)	Primary Charge Termination Method ¹	Safety Timer	Temp Monitor	Packaging: QFN/MLP	EVM	Comments	Price*
Multi-Cell Switch-Mode Stand-Alone Battery Chargers with Internal FETs (Converters) — Lithium-Ion												
bq24170/71/72/33	1 to 3	Switching	Yes	4.0/2.5 A	20	Min current	Yes	Yes	24	✓	¹ 171 supports JEITA, ¹ 72 supports adjustable charge voltage and ¹ 33 supports 2.5 A	1.80
bq24100/8	1	Switching	Yes	2.0 A	20	Min current	Yes	Yes	20		bq24120 offers enhanced EMI performance	2.00
bq24103A/113A	1 or 2	Switching	Yes	2.0 A	20	Min current/Host controlled	Yes	Yes	20		bq24123 offers enhanced EMI performance	2.00
bq24105 ¹ /115	1 to 3	Switching	Yes	2.0 A	20	Min current/Host controlled	Yes	Yes	20		bq24125 offers enhanced EMI performance	3.50

¹Host controlled = system processor must terminate charging.

¹Devices qualified for Automotive applications are available. Different pricing may apply.

New devices are listed in bold red.

*Suggested resale price in U.S. dollars in quantities of 1,000.

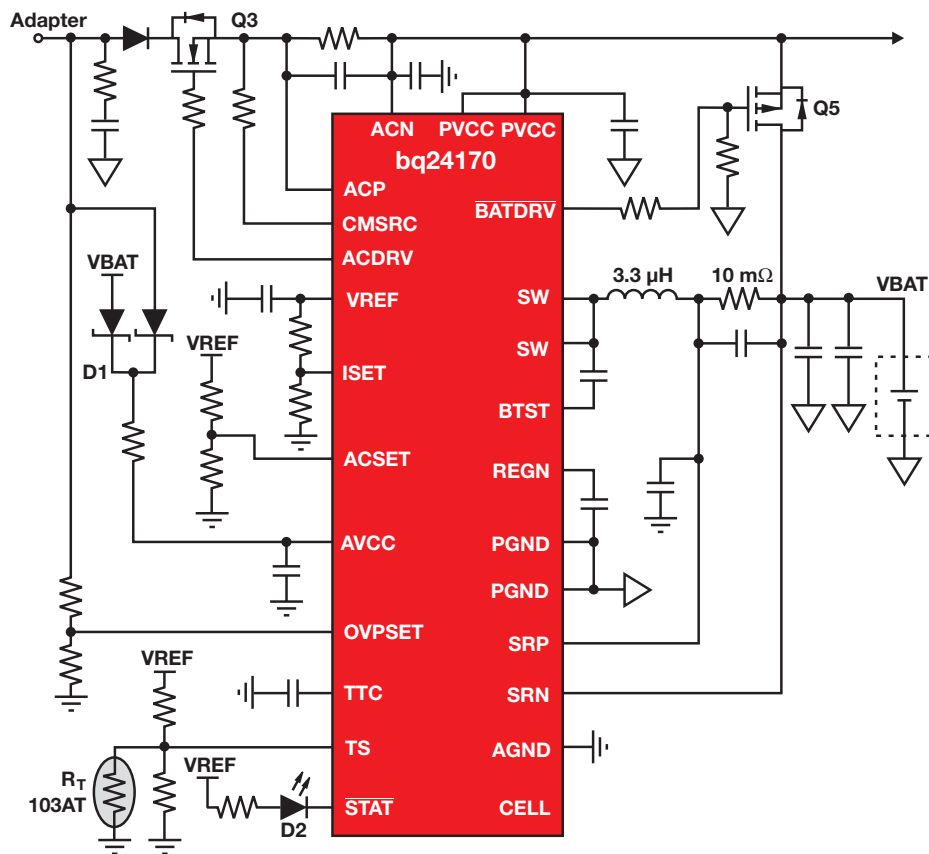

Battery Management Products

Battery Charge Management

Selection Guide

Device	Number of Cells	Control Topology ¹	Integrated Power FET	Charge Current Internal FET	V _{IN} Max	Primary Charge Termination Method ²	Safety Timer	Temp Monitor	Packaging						EVM	Comments	Price*
									WCSP	QFN/MLP	MSOP	TSSOP	SOIC	DIP			
Multi-Chemistry (Li-Ion and NiCd/NiMH)																	
bq2000/T	Multiple	Switching	No	—	7 V	PVD, $\Delta T/\Delta t$, min current	Yes	Yes				8	8	8	✓	Charges NiCd, NiMH, and Li-Ion	1.50
bq24765	2 to 4	Switching	Yes	8.0 A	30 V	SMBus	Yes	No	34						✓	SMBus charger with integrated power FETs	3.95
bq24650	1 to 6	Switching	No	—	33 V	Min current	Yes	Yes	16						✓	Solar charger for Li-Ion/polymer, LiFePO ₄ , lead acid chemistries	2.85
bq24747	2 to 4	Switching	No	—	30 V	SMBus	Yes	No	28						✓	SMBus with input current-detect comp.	2.90
Li-Ion Chemistry																	
bq24707	1 to 4	Switching	No	—	30 V	SMBus	Yes	No	20						✓	Allows host to control power source selection	2.90
bq24725	2 to 4	Switching	No	—	30 V	SMBus	Yes	No	20						✓	Controls all NMOS FETs for auto power source selection	3.10
bq24030	1	Linear	Yes	1.5 A	18 V	Min current	Yes	Yes	20						✓	Dynamic Power-Path Management powers the system and charges battery	1.80
	Parameter		bq24030 [†]		bq24031 [†]		bq24032A		bq24035		bq24038						
	Output for AC Input Condition		Regulated to 6 V		Regulated to 6 V		Regulated to 4.4 V		Cutoff at 6 V		Regulated to 4.4 V						
	Charge Regulation Voltage (V)		4.2		4.1		4.2		4.2		4.2/4.36 Selectable						
bq24040	1	Linear	Yes	0.8 A	30 V	Min current	Yes	Yes	10						✓	USB compliant charger with smallest footprint	0.90
	Parameter		bq24040		bq24041												
	VOVP		6.6 V		7.1 V												
	Optional Functions ³		TS and JEITA		BAT_EN												
bq24050	1	Linear	Yes	0.8 A	30 V	Min current	Yes	Yes	10/12						✓	Automatic USB detection; supports JEITA	0.99
	Parameter		bq24050		bq24052		bq24055										
	Optional Functions ³		—		—		PG										
	RNTC (Ω)		10 k		100 k		10 k										
bq24072	1	Linear	Yes	1.5 A	28 V	Min current	Yes	Yes	16						✓	Dynamic Power-Path Management, USB compliant	1.20
	Parameter		bq24072T		bq24073		bq24074		bq24075T		bq24079T						
	V _{BAT}		4.2 V		4.2 V		4.2 V		4.2 V		4.1 V						
	V _{OVP}		6.6 V		6.6 V		10.5 V		6.6 V		6.6 V						
	V _{OUT(REG)}		V _{BAT} + 225 mV		4.4 V		4.4 V		5.5 V		5.5 V						
	Pin #15		TD		TD		TERM		SYSOFF		SYSOFF						
bq24090	1	Linear	Yes	0.8 A	7 V	Min current	Yes	Yes	10						✓	USB compliant charger	0.70
	Parameter		bq24090		bq24091		bq24092		bq24093								
	RNTC (Ω)		10 k		100 k		10 k		100 k								
	Optional Functions ³		—		—		JEITA		JEITA								
bq25040/60	1	Linear	Yes	1.1/1.0 A	30 V	Min current	No	Yes	10						✓	USB compliant w/ 50-mA integrated LDO, 6.9-V/10.5-V OVP	1.20
bq24210	1	Linear	Yes	800 mA	20 V	Min current	Yes	Yes	10						✓	Solar charger input	1.10
bq24153A/56A	1	Switching	Yes	1.25/1.50 A	20 V	Host controlled	Yes	No	20						✓	I ² C charger, bq24153A supports USB OTG	2.00
bq24180/5	1	Switching	Yes	1.55 A	20 V	Host controlled	Yes	Yes	25						✓	Accessory power output, bq24185 supports USB OTG	2.20/2.00
bq24170/71/72/33	1 to 3	Switching	Yes	4.0/2.5 A	20 V	Min current	Yes	Yes	24						✓	'171 supports JEITA, '172 supports adjustable charge voltage, and '133 supports 2.5 A	1.80
bq24600/10/16/18	1 to 6	Switching	No	—	32 V	Min current	Yes	Yes	16/24						✓	'16 supports JEITA, '18 supports 4.7 V _{IN} min	Multiple
bq24617	1 to 5	Switching	No	—	26 V	Min current	Yes	Yes							✓		2.90
LiFePO₄																	
bq25070	1	Linear	Yes	1.0 A	30 V	LiFePO ₄ -specific	No	Yes	10						✓		1.20
bq24620/30	1 to 7	Switching	No	—	33 V	Min current	Yes	No	16/24						✓	bq24630 supports system power selector	2.90
SuperCap																	
bq24640	1 to 9	Switching	No	—	33 V	SuperCap-specific	No	Yes	16						✓		3.75
NiCd/NiMH Chemistry																	
bq2002/C/E/F	Multiple	Current-limited	No	—	—	-ΔV, PVD, $\Delta T/\Delta t$	Yes	Yes				8	8		✓	Low-cost nickel charge ICs	0.85
bq2004/E/H	Multiple	Switching	No	—	—	-ΔV, PVD, $\Delta T/\Delta t$	Yes	Yes				16	16		✓	Selectable timers and pulse-trickle rates	2.15
bq2005	Multiple	Switching	No	—	—	-ΔV, $\Delta T/\Delta t$	Yes	Yes				20	20			Sequential fast charge of two battery packs	2.20
bq24400/1	Multiple	Switching	No	—	—	PVD / $\Delta T/\Delta t$	Yes	Yes				8	8				1.55
Lead-Acid Chemistry																	
bq24450	Multiple	Linear	No	—	40 V	Max V, min I	No	No				16	16			Temp-compensated internal reference	2.75
UC3909	Multiple	Switching	No	—	40 V	Max V, min I	No	Yes				20	20			Differential current sense input	3.05
bq2031	Multiple	Switching	No	—	—	Max V, -Δ ² V, min I	Yes	Yes				16	16		✓	Three user-selectable charge algorithms to accommodate cyclic and standby applications	2.80

¹Current-limited = gating control of external, current-regulated/limited source.

²PVD = peak voltage detection; $\Delta T/\Delta t$ = rate of temperature rise; host controlled = system processor must terminate charging; -ΔV = negative voltage change; max V = maximum voltage; min I = minimum current; -Δ²V = second difference of cell voltage.

³TS = temperature sensing; PG = power good; BAT_EN = charge enable;

JEITA = meets JEITA safety specification.

[†]Devices qualified for Automotive applications are available. Different pricing may apply.

*Suggested resale price in U.S. dollars in quantities of 1,000.

New devices are listed in bold red.
Preview devices are listed in bold blue.

Battery Management Products

→ Single-Cell Solutions – Battery Fuel Gauges

Design Factors

Battery Chemistry – Each battery chemistry has different operating characteristics, such as discharge profiles and the self-discharge rate. The battery chemistry is programmed in the dataflash of the TI fuel gauge to account for these differences. In addition, the conditions of the end-equipment system can be programmed in the gas gauge. Designers can choose to implement the gauge in the

host system or inside the battery pack. The programmed information is processed in TI's Impedance Track™ gauging technology for prediction of remaining battery capacity with >99% accuracy.

Features

TI gas gauges and battery monitors accurately track battery activity to compute the remaining battery capacity and system run-time. The following features are available:

- Patented Impedance Track battery fuel-gauging technology for >99% accuracy
- System- and pack-side implementation
- Turnkey solution with complete CPU and battery fuel-gauge firmware
- Interrupt-driven gas gauge signaling the host with the battery's specific state-of-charge status
- Gas gauge with integrated LDO in small packages

System-Side Impedance Track™ Fuel Gauge with Integrated LDO

bq27520-G2

Get samples, datasheets, evaluation modules and app reports at: www.ti.com/sc/device/bq27520-G2

The bq27520-G2 is a high-performance, system-side fuel gauge with excellent accuracy, low power consumption and extremely small package size. By integrating the fuel-gauge function into the system board, portable-equipment designers can use an embedded or removable standard battery pack while adding the capability to accurately display remaining pack capacity and estimated run time. The bq27520-G2 features an integrated voltage regulator that reduces the total component count for the system. The bq27520-G2 also has an interrupt-generation capability that reduces the software burden on the system processor because the fuel gauge does not require repetitive polling from the host.

The bq27520-G2 uses the patented Impedance Track™ algorithm for fuel gauging and provides information such

as remaining battery capacity, state of charge, minimum run time to empty, battery voltage, temperature and state of health. Battery fuel gauging with the

bq27520-G2 requires only PACK+ (P+), PACK- (P-) and thermistor (T) connections to a removable battery pack or embedded battery circuit.

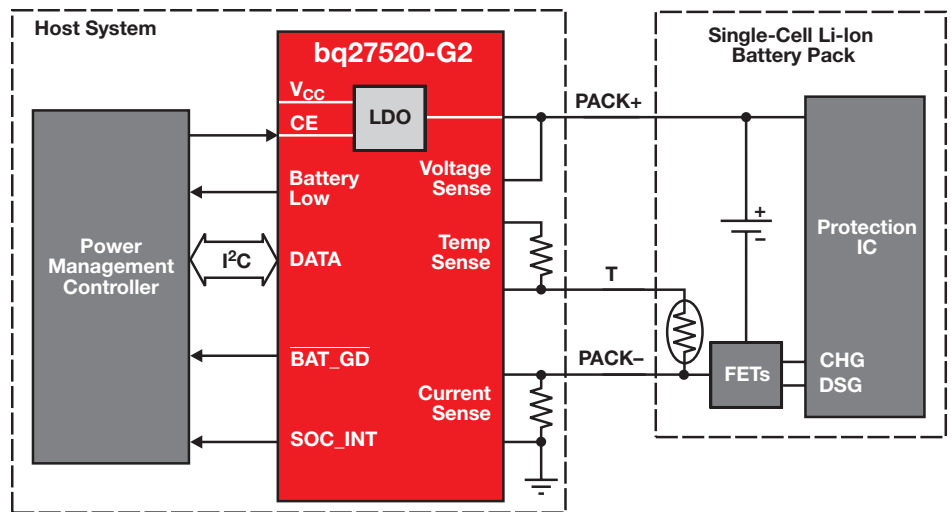

Selection Guide

Device	Approx. Battery Capacity (mAh)	Min Max Series Cell	Number of LEDs	Communication Protocol	Other Features	Package	Price*
Lithium-Ion, Lithium-Polymer Chemistry							
bq27000	300 to 6000	1	—	HDQ	Single-cell fuel gauge with fixed-voltage EOD	10-pin DRK	1.15
bq27200	300 to 6000	1	—	I ² C	Single-cell fuel gauge with fixed-voltage EOD	10-pin DRK	1.15
bq27010	300 to 6000	1	—	HDQ	Single-cell fuel gauge with compensated-voltage EOD	10-pin DRK	1.25
bq27210	300 to 6000	1	—	I ² C	Single-cell fuel gauge with compensated-voltage EOD	10-pin DRK	1.25
bq27500-V130	300 to 6000	1	—	I ² C	Single-cell system-side fuel gauge w/ Impedance Track™ technology	12-pin QFN	1.35
bq27510-G2	300 to 6000	1	—	I ² C	Single-cell system-side fuel gauge w/ Impedance Track technology with integrated LDO	12-pin QFN	1.45
bq27541-V200	300 to 6000	1	—	I ² C/HDQ	Single-cell battery-side fuel gauge w/ Impedance Track technology with authentication challenger	12-pin QFN	1.45
bq27501	300 TO 6000	1	—	I ² C	Single-cell system-side fuel gauge w/ Impedance Track technology with battery ID resistor	12-pin QFN	1.35
bq27505-J4	300 TO 6000	1	—	I ² C	Single-cell system-side fuel gauge w/ Impedance Track technology	12-ball CSP	1.40
bq27520-G2	300 to 6000	1	—	I ² C	Single-cell system-side fuel gauge w/ Impedance Track technology with integrated LDO	15-ball CSP	1.50

*Suggested resale price in U.S. dollars in quantities of 1,000.

New devices are listed in bold red.

Battery Management Products

→ Single-Cell Solutions – Authentication for Batteries and Peripherals

Design Factors

Original equipment manufacturers specify products to achieve required performance and safety goals. Authentication ensures that connected devices fulfill the established requirements and are safe for the consumer.

Features

TI authentication devices use three levels of security.

- **Identification Number** – The host controller can request an identification number that is answered with a fixed response.
- **CRC Algorithm** – The host processor sends a random challenge and reads the response that is an encoding of the challenge and a shared secret key through a CRC with a shared secret polynomial.
- **SHA-1 Encryption** – The host processor sends a random challenge and reads the response that is an encoding of the challenge and a shared secret key through the SHA-1 cryptographic primitive.

Single-Cell Battery Pack with Gas Gauge and Authentication

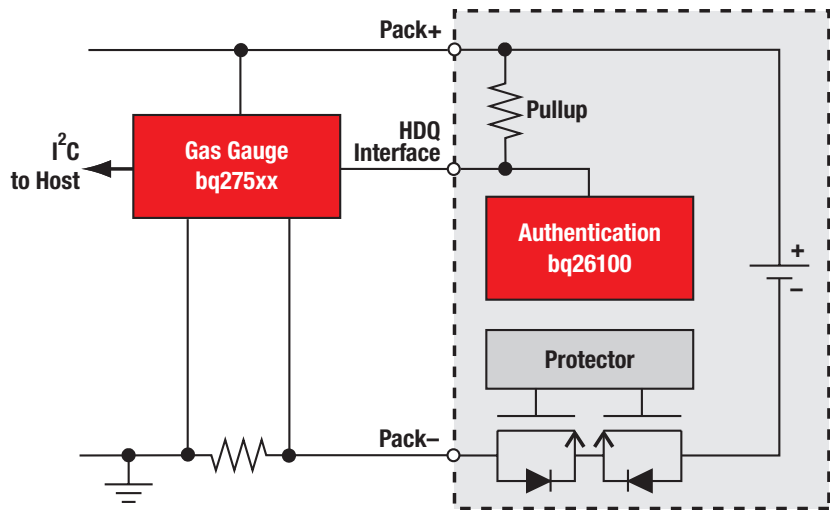

Selection Guide

Device	Interface	Pins	Security	Temp (°C)	Price*
bq2022A	SDQ™	3	ID number	-40 to 85	0.90
bq2024	SDQ	3	ID number	-40 to 85	0.95
bq26150	HDQ	5	CRC algorithm	-20 to 70	0.95
bq26100	SDQ	5	SHA-1 encryption	-20 to 70	0.99
bq27541-V200	I ² C/HDQ	12	SHA-1 encryption	—	1.45

*Suggested resale price in U.S. dollars in quantities of 1,000.

New devices are listed in bold red.

Battery Management Products

→ Multi-Cell Solutions – Battery Fuel Gauges

Design Factors

Battery Chemistry – Each battery chemistry has different operating characteristics, such as discharge profiles and self-discharge rate. TI gas gauge ICs are developed by chemistry to account for these differences to accurately display remaining energy in the battery.

Features

TI gas gauges and battery monitors accurately track battery activity to compute the remaining battery capacity and system run-time. They feature:

- Simple communication protocols.
- High-resolution analog-to-digital converters for accurate charge/discharge measurement.
- Integrated CPU on gas gauges to compute remaining battery capacity and run-time.
- Advanced charge management satisfies JEITA specification of variable charging current and voltage with battery conditions.

99% Accurate Gas Gauge Maximizes Run-Time

bq20z40-R1, bq20z45-R1, bq20z60-R1, bq20z65-R1

Get samples, datasheets, evaluation modules and app reports at:

www.ti.com/sc/device/bq20z40-R1

The dynamic Impedance Track™ gas gauge algorithm in the bq20z40 extends battery usability, allowing use of the full chemical capacity available in a battery pack. Additional features include instant state-of-charge and real-time impedance learning. Impedance Track also enables reduction in development and production time. Remaining capacity is reported over the entire life of the battery pack with better than 99% accuracy. The bq20z40-R1 is ideally suited for battery packs used in medical and industrial equipment, back-up batteries and laptop computers.

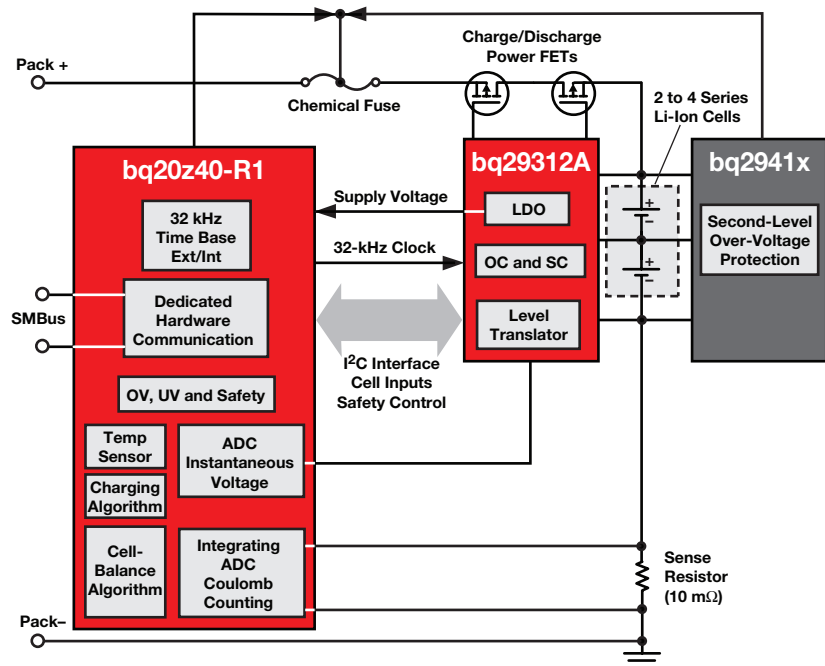

Typical gas-gauge application.

Battery Fuel Gauges Family of Products

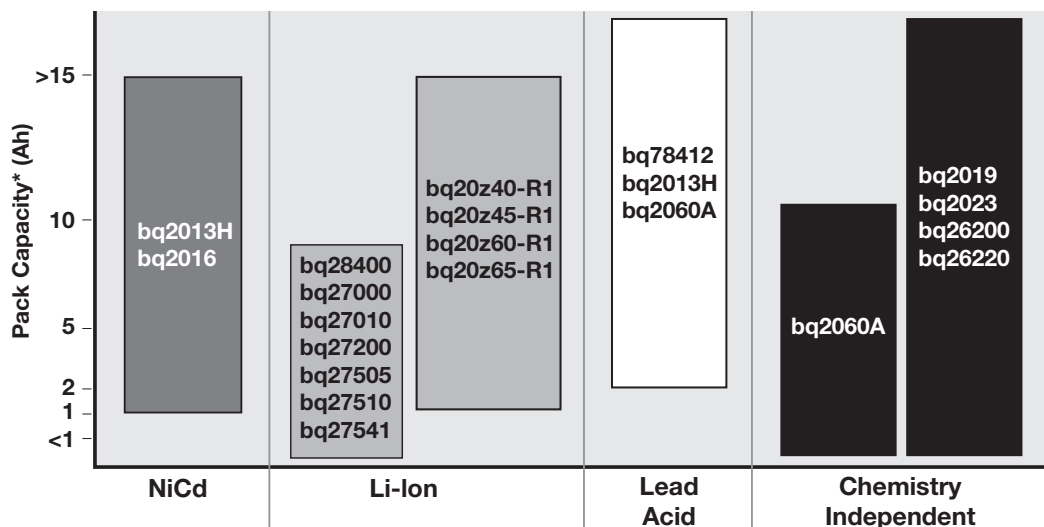

*Pack capacity ratings provide an approximate range for each gas gauge.

Battery Management Products

→ Multi-Cell Solutions — Battery Fuel Gauges

Selection Guide

Device	Approx. Battery Capacity (mAh)	Min Max Series Cell	Number of LEDs	Communication Protocol	Other Features	Package	Price*
NiCd, NiMH Chemistry							
bq2013H	2000 to 15000	—	5	Single wire (HDQ)	Programmable offset error compensation	16-pin SOIC	3.70
bq2014H	500 to 6000	—	5	Single wire (HDQ)	Register compatible with bq2050H	16-pin SOIC	4.60
bq2016	1000 to 4500	—	5	Single wire (HDQ)	Automatic offset calibration	28-pin SSOP	3.75
Lithium-Ion, Lithium-Polymer Chemistry							
bq28400	500 to 16000	2	—	SMBus	CEDY+ gas gauge with integrated protector	20-pin TSSOP	3.20
bq3060	500 to 32000	2 to 4	—	SMBus	CEDV+ gas gauge with integrated protector	24-pin TSSOP	3.55
bq20z40-R1	800 to 32000	2 to 4	—	SMBus	Impedance Track™ fuel gauge for use with bq29330 protector	20-pin TSSOP	3.65
bq20z45-R1	800 to 32000	2 to 4	—	SMBus	Impedance Track fuel gauge with integrated protector	38-pin TSSOP	4.45
bq20z60-R1	800 to 32000	2 to 4	3, 4 or 5	SMBus	Impedance Track fuel gauge with LED for use with bq29330 protector	30-pin TSSOP	3.90
bq20z65-R1	800 to 32000	2 to 4	3, 4 or 5	SMBus	Impedance Track fuel gauge with LED and integrated protector	44-pin TSSOP	4.75
bq78PL114	1000 to 650,000	3 to 12	—	SMBus	High-power gas gauge with protection and advanced cell balancing	48-pin QFN	4.50
bq78PL116	1000 to 650,000	3 to 16	—	SMBus	High-power gas gauge with protection and advanced cell balancing	48-pin QFN	4.50
bq76PL102	—	1 to 2	—	PowerLAN™	2-cell cell expansion to bq78PL114 and bq78PL116	12-pin QFN	0.90
Lead Acid Chemistry							
bq78412	1000 to 327,000	—	10	UART	Pb-acid battery state-of-charge indicator with run-time display	44-pin HTSSOP	3.90
Multi-Chemistry							
bq2060A	800 to 10000	2 to 4	5	SMBus or HDQ	Most accurate multi-chemistry gauge from TI	28-pin SSOP	3.90
Battery Monitors							
bq2019	>20000	—	—	Single wire (HDQ)	64-bit ID ROM and 1 program output non-volatile memory	8-pin TSSOP	1.95
bq2023	>20000	—	—	Single wire (SDQ)	64-bit ID ROM and 1 program output automatic offset error calibration	8-pin TSSOP	2.00
bq26200	>20000	—	—	Single wire (HDQ)	High-performance battery, coulomb counter	8-pin TSSOP	2.00
bq26220	>20000	—	—	Single wire (HDQ)	64-bit ID ROM and 1 program output on-chip voltage measurement	8-pin TSSOP	2.05
bq76PL536	—	3 to 192	—	SPI	3- to 6-cell EV and UPS stackable monitor and cell-balancing AFE	64-pin HTQFP	4.30

*Suggested resale price in U.S. dollars in quantities of 1,000.

New devices are listed in bold red.

For a complete list of Resources, visit: power.ti.com

Battery Management Products

Multi-Cell Solutions — Lithium-Ion Protection

Design Factors

Number of Series Cells — A battery pack is constructed from a string of series and parallel cells. Each series cell, or group of parallel cells, requires protection from overcharge, overdischarge and short-circuit conditions.

Threshold Voltage — Li-Ion and Li-Polymer cells are produced by many manufacturers. Some manufacturers' technologies create cells of different maximum stress voltages, otherwise known as the "overvoltage threshold." This data is available from the cell supplier.

Threshold Tolerance — The overvoltage threshold has a tolerance that needs to be accounted for in the design for safety reasons.

Shutdown Current — In battery pack applications, constant current draw needs to be very low to preserve battery life.

Charge/Discharge Current — The pass element associated with each protection IC is rated for maximum current whether it be an internal or external FET.

Features

- BiCMOS process results in low current consumption.
- Different overvoltage thresholds allow one design to work with several cell suppliers.
- Sleep current consumption of less than 3.5 μA enables extended battery life.
- 50 mV precision internally trimmed thresholds maximize safety.
- Short-circuit protection eliminates the need for an external fuse.

Stand-Alone Multi-Cell Precision Protector for Li-Ion Chemistries

bq77910

Get datasheets at: www.ti.com/sc/device/bq77910

The bq77910 precision protector is a complete stand-alone, self-contained battery-protection and cell-balancing device intended for Li-Ion/Li-Polymer battery packs.

The bq77910 monitors 4 to 10 series individual cell voltages and provides fast-acting outputs that can be used to drive n-channel MOSFETs to interrupt the power path. Activation delays and recovery methods for each safety condition are fully programmable in nonvolatile memory.

Key Features

- 4-, 5-, 6-, 7-, 8-, 9- or 10-series cell protection
- Individual cell-voltage monitoring
- Low-side NMOS FET drive for charge and discharge control
- Compatible with 1-m Ω current-sense resistor
- Supply-voltage range: 5.6 V to 50 V
- Integrated 3.3-V micropower LDO regulator

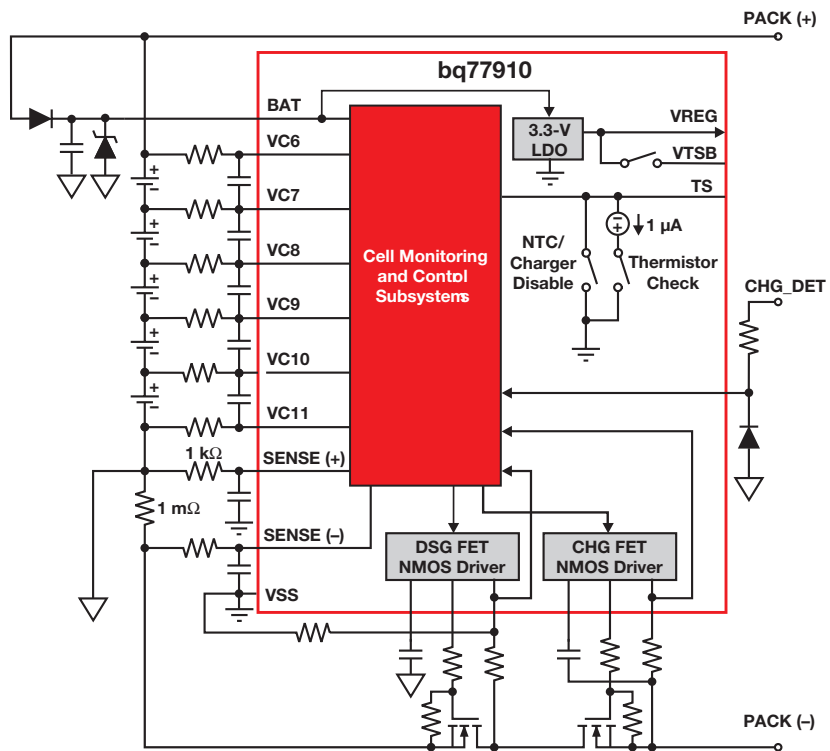

5-cell, series FET configuration schematic using the bq77910.

Selection Guide

Device	Number of Series Cells	Charge/Discharge Current (A)	Shutdown Current (μA)	Other Features	Package	Price*
bq2920x	2	—	3	Overvoltage safety with cell balancing	8-pin SON	0.30
bq29330	2, 3 or 4	External FET	1	Integrated LDO, works directly with bq20z90 gas gauge	20-pin TSSOP	1.00
bq2942x	2, 3 or 4	—	3	Overvoltage safety for chemical fuse activation; PTC	8-pin TSSOP	0.45
bq2944x	2, 3 or 4	—	3	Overvoltage safety for chemical fuse activation	8-pin SON	0.45
bq77PL900	5 to 10	External PFET	—	Stand-alone or host-controlled protector with cell balancing	48-pin SSOP	2.95
bq77910	4 to 10	External NFET	—	Stand-alone protector with cell balancing	38-pin TSSOP	2.70
bq77PL157A4225	3 to 6	External NFET	3	Stackable overvoltage protector; stack 3 for 18 series cells	16-pin TSSOP	0.65

¹ Controlled by bq208x, bq20z8x or bq20z9x gas gauge.

See individual datasheets for full details.

*Suggested resale price in U.S. dollars in quantities of 1,000.

New devices are listed in bold red.

→ Overview

Distributing and controlling power—even after the correct voltage is derived—is becoming more complex. Because increasing numbers of voltage rails are required in today’s advanced processing or embedded systems, distributing and managing these rails is a constant challenge.

In these systems, load switches, MUXes, or inrush-protection devices are routinely

required to safely route power where it is needed and deliver it properly. When power needs to be moved from system to system, issues like hot-swap control, safety certification, and monitoring are quickly top priorities.

Digital control takes all of these concerns and capabilities to yet another level. Microprocessor control and monitoring in system health and power blocks gives

designers even more options to improve the robustness of their system. Using digital interfaces to various functional blocks and sensors, it is possible to monitor the amount of power or current being consumed, the temperature of the system, or other variables, and then take action.

→ Power-over-Ethernet

The concept of providing power along with data is as old as plain old telephone service, but the formal standard for providing power along Ethernet lines is much more recent. Though the original Power-over-Ethernet (PoE) specification was approved in 2005, the IEEE ratified a superseding standard in summer 2009—the IEEE 802.3at. Both standards specify behavior for devices receiving power across Ethernet lines, known as “powered devices” (PDs), and methods for injecting power onto the line, used in equipment known as “power sourcing equipment” (PSE).

Original PoE . . . Only Better!

The vast majority of PoE applications need less than 12.95 W. For this growing market area, TI has a large portfolio of options to consider:

TPS23753A

- Simplest, most elegant, lowest-cost solution for a standard PoE PD
- Incorporates rugged tolerance for extended ESD exposure
- Auxiliary power supplies are fully supported—down to 12 V!

New PoE Products for a New Standard!

TPS23757

- Secondary gate driver enables high-efficiency, isolated topologies for applications requiring 12.95 W or less
- Pin-for-pin compatible with the TPS23756, providing an easy path for low- or high-power applications
- Operates with auxiliary input power supplies as low as 12 V

TPS23750

- TI’s original PD front end plus DC/DC converter
- Supports simple, low-cost, non-isolated buck-converter topologies with no transformer required

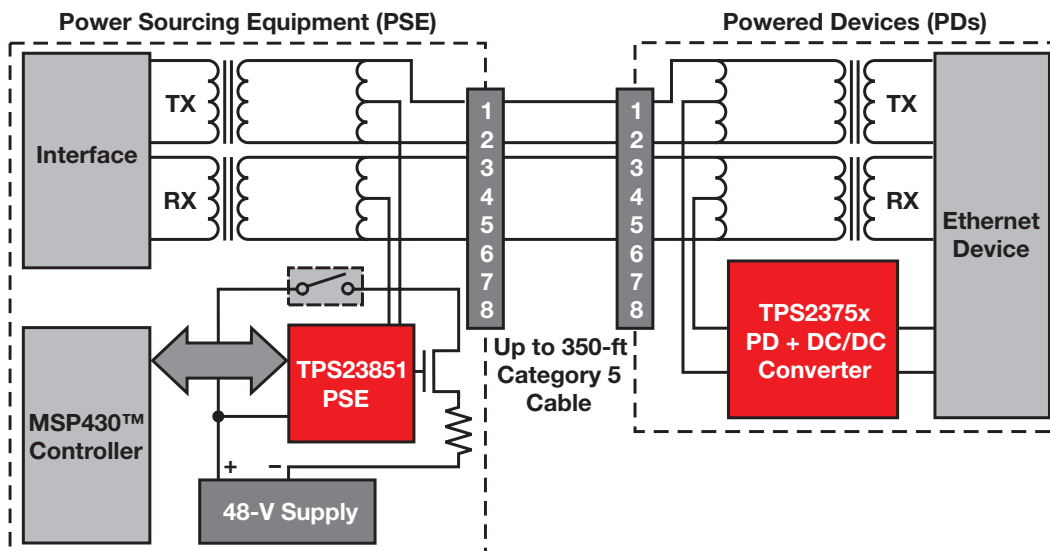

The new TPS23851 and TPS2375x are IEEE 802.3at-compliant power-management ICs designed for managing the connection between Power Sourcing Equipment (PSE) and Powered Devices (PDs) over Ethernet cables (see: www.ti.com/poe). The TPS23851 is a quad-port PSE power manager with external FETs and individual ADCs per port for maximum monitoring and control.

→ Protection and Power Switches

Protection Circuitry

Protecting designs from unwanted inrush current, reverse current flow, or malfunction is challenging. The following questions and answers cover typical application design issues.

Can the board ever pull too much current?

If the design involves devices that plug into live systems (hot swaps), the answer is probably “yes.” Also, if the design has subsystems that need to be turned on and off via a pass FET or some other device, unwanted inrush current could be a problem when those systems are activated. In these cases, choosing a current-limiting switch or a hot-swap manager will control this input. Here are

some key considerations that will make product selection easier:

1. *What is the voltage? How much nominal current does the system draw?* If the system has low voltage (< 20 V) and draws less than 5 A continuously, a hot-swap controller such as the TPS2420/1 with an internal FET and sense element is a likely choice. For higher voltages and/or higher currents, an external FET and a hot-swap controller IC such as the TPS2492/3 is a good solution.
2. *Are defined periods of time needed during which additional current can flow to the load (for example, during start-up)?* If so, a constant-current switch or a configurable timer on a hot-swap controller is important.

Good examples of these are the TPS2552/3 devices, which are simple switches with only thermal shutdown, and the TPS2420, which has a configurable timer.

3. *Does the amount of current flowing to the load need to be monitored?* The TPS2420 and TPS2x58/9 have analog current-monitoring pins that are ideal for use with sequencers such as the UCD90124 on page 84 or with any microcontroller with an onboard ADC such as TI’s MSP430™ MCU. The TPS2480/1 external FET devices have directly addressable digital outputs of current readings via I²C.

Is the power supply at risk from reverse current flow?

If the system has a battery backup, supercapacitor, or alternate power supply, the

Low-Voltage Protection-Circuitry Products

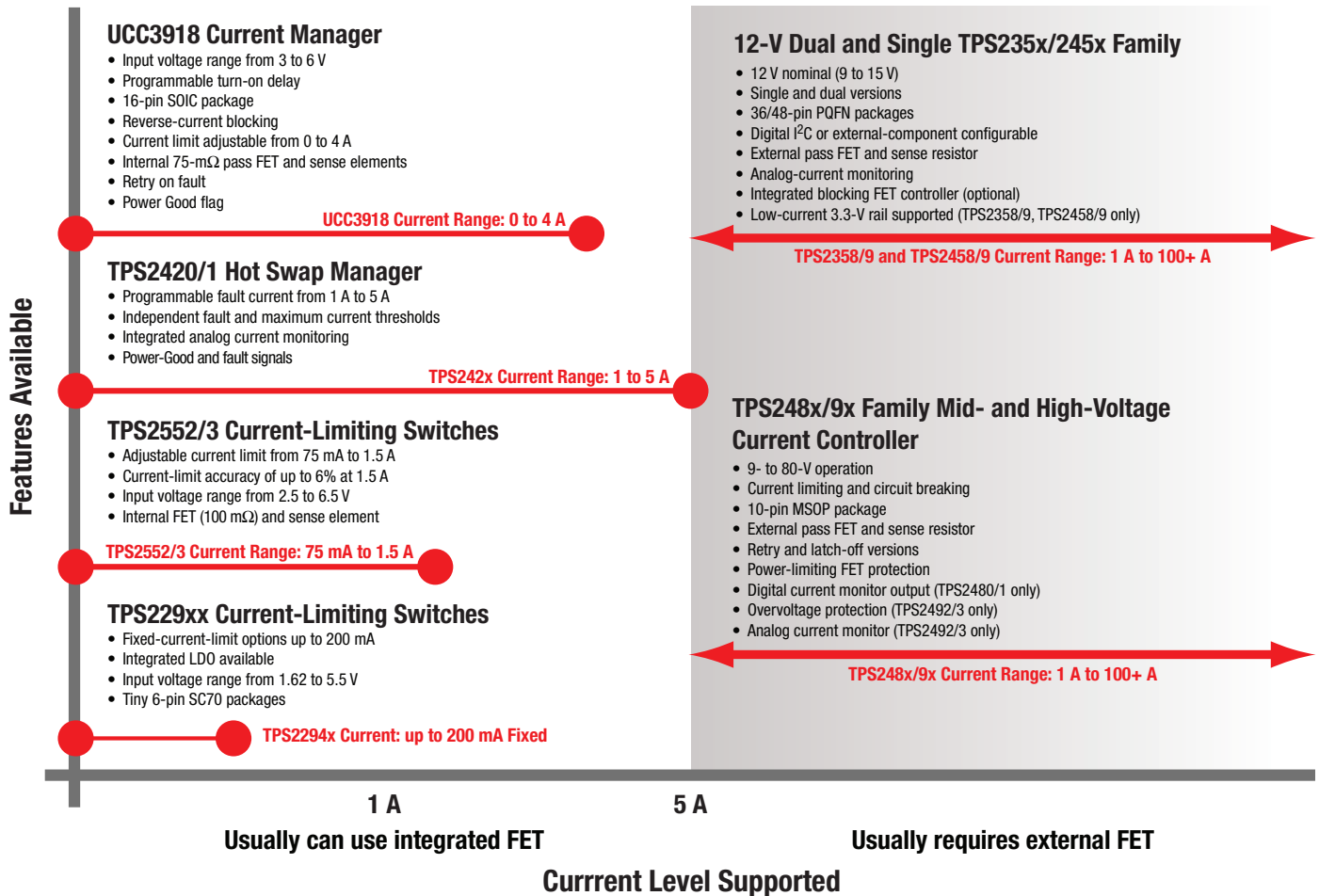

→ Protection and Power Switches

Protection Circuitry (Continued)

answer is probably “yes.” Also, if it is important to control which source is powering the board, ORing FET controllers such as the TPS2410 or combination devices could be very useful. Here are some key questions to consider:

1. *What is the voltage? How much nominal current does the system draw?*
For systems from 0.8 V to 16.5 V,

the TPS2410/1/2/3 are great options that control external FETs, providing flexibility for the amount of current passing through to the load. Features like soft start, nuisance trip filters, and external control via UV/OV pins are key aspects for many designs.

2. *Are the system’s currents and voltages low enough to use a single device?* Many lower-voltage (2.7- to 6.5-V) solutions that consume less

than 1.5 A per rail could make use of integrated MUX devices such as those on page 82.

If protection from both reverse current and inrush current is needed, check out the TPS2456/8/9 devices, which incorporate both an ORing FET controller and a hot-swap controller.

Integrated 12-V Hot Swap Controller and ORing FET Controller

TPS2456

Get samples, datasheets, evaluation modules and app reports at: www.ti.com/sc/device/TPS2456

Features

- Hot-swap control on 12-V rails
- ORing for 12 V on board
- Fast breaker for short-circuit protection
- Minimal external components
- Analog current monitoring outputs for each channel

Applications

- Telecom connectivity
- Processors
- Network communication processors (NPU)
- Mass storage
- Ideal for 12-V MUX applications and systems requiring scalability and redundancy

Enabling technology for any 12-V based system, such as telecom carrier boards, MicroTCA® power modules and Advanced Mezzanine Cards.

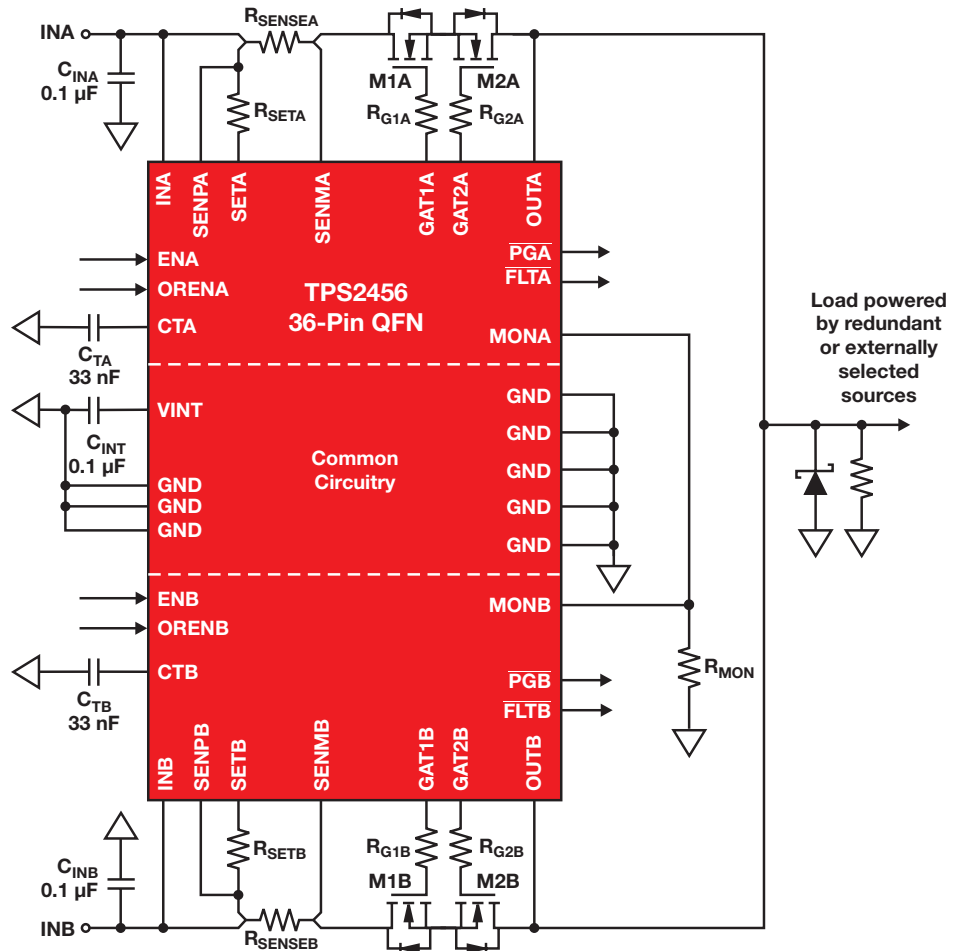

Power Protection and Control

→ Protection and Power Switches

Hot Swap Switches (Integrated FET) Selection Guide

Device	Target Applications	Channels	V _{IN} (V)	Current Limit (A)	r _{DS(on)} per FET (typ) (mΩ)	Enable/Shutdown	Ramp	Package(s)	Price*
TPS2420	Hot swap with current monitor & pwr limiting	1	3 to 20	1 to 5	20	1L	Current	16-pin SON	1.95
TPS2421-1	Hot swap with pwr limiting, latch-off on fault	1	3 to 20	1 to 5	20	1L	Current	SOIC-8	1.60
TPS2421-2	Hot swap with pwr limiting, retry on fault	1	3 to 20	1 to 5	20	1L	Current	SOIC-8	1.60
TPS2552	Current-limiting switch, constant-current	1	2.5 to 6.5	0.75 to 1.5	85	1L	Current	6-pin SOT-23, SON	0.70
TPS2552-1	Current-limiting switch, latch-off on fault	1	2.5 to 6.5	0.75 to 1.5	85	1L	Current	6-pin SOT-23, SON	0.70
TPS2553	Current-limiting switch, constant-current	1	2.5 to 6.5	0.75 to 1.5	85	1H	Current	6-pin SOT-23, SON	0.70
TPS2553-1	Current-limiting switch, latch-off on fault	1	2.5 to 6.5	0.75 to 1.5	85	1H	Current	6-pin SOT-23, SON	0.70
TPS2554	Current-limiting switch, constant-current	1	4.5 to 5.5	0.25 to 2.8	73	1H	Current	8-pin SON	0.80
TPS2555	Current-limiting switch, constant-current	1	4.5 to 5.5	0.25 to 2.8	73	1L	Current	8-pin SON	0.80
TPS2556	Current-limiting switch, constant-current	1	2.5 to 6.5	0.5 to 5	22	1L	Current	8-pin SON	0.90
TPS2557	Current-limiting switch, constant-current	1	2.5 to 6.5	0.5 to 5	22	1H	Current	8-pin SON	0.90
TPS2560	Current-limiting switch, constant-current	2	2.5 to 6.5	0.25 to 2.5	45	2L	Current	10-pin SON	0.90
TPS2561	Current-limiting switch, constant-current	2	2.5 to 6.5	0.25 to 2.5	45	2H	Current	10-pin SON	0.90
TPS2590	Current-limiting switch, configurable fault	1	3 to 20	1 to 5	20	1L	Current	16-pin SON	1.05
UCC3915	Enclosure management, general	1	7 to 15	0 to 3	150	1L	Current	SOIC-16, TSSOP-24	2.55
UCC3912	RAID, SCSI, general	1	3 to 8	0 to 3	150	1L	Current	SOIC-16, TSSOP-24	2.30
UCC3918	RAID, SCSI, general	1	3 to 6	0 to 4	75	1L	Current	SOIC-16, TSSOP-24	2.35

*Suggested resale price in U.S. dollars in quantities of 1,000.

Preview devices are listed in bold blue.

Hot Swap Controllers (External FET) Selection Guide

Device	Target Applications	Channels	V _{IN} Range (V)	Enable/Shutdown	UV	OV	Fault	PG	Latch	Auto Retry	Ramp	Power Limiting	Package(s)	Price*
TPS2300/01	CompactPCI®, general	2	3 to 13/3 to 5.5	1L/1H	✓		✓	✓	✓		Voltage	No	20-pin TSSOP	1.60
TPS2310/11	CompactPCI, general	2	3 to 13/3 to 5.5	1L/1H	✓		✓	✓	✓		Voltage	No	20-pin TSSOP	1.60
TPS2320/21	CompactPCI, general	2	3 to 13/3 to 5.5	1L/1H	✓		✓	✓	✓		Voltage	No	16-pin SOIC/TSSOP	1.35
TPS2330/31	CompactPCI, general	1	3 to 13	1L/1H	✓		✓	✓	✓		Voltage	No	14-pin SOIC/TSSOP	1.25
UCC3919	Low-voltage general hot swap	1	3 to 8	1H			✓		S ¹	S ¹	Current	No	16-pin SOIC/TSSOP	2.35
TPS2342	CompactPCI, PCI-X®, PC-X2.0	12	3.3, V _{aux} , V _{I/O} , 5, +12, -12	1L	✓			✓	✓		Voltage	No	80-pin HTQFP	7.00
TPS2343	CompactPCI, PCI-X, PC-X2.0	12	3.3, V _{aux} , V _{I/O} , 5, +12, -12	1L	✓			✓	✓		Voltage	No	80-pin HTVSOP	7.50
TPS2350	Full featured -48-V telecom, LS active ORing	2	-12 to -80	1H	✓	✓	✓	✓		✓	Current	No	14-pin SOIC/TSSOP	1.90
TPS2358	xTCA mezzanine cards, general 12 V	2	8.5 to 17	2L	✓		✓	✓	✓		Current	No	48-pin QFN	4.00
TPS2359	xTCA mezzanine cards, general 12 V	2	8.5 to 17	1H/1L	✓	✓	✓	✓	S ¹	S ¹	Current	No	36-pin QFN	5.00
TPS2363	PCI Express®	6	3.3 V _{aux} , 3.3, +12	1L	✓		✓	✓	✓		Voltage	No	48-pin QFP	2.50
TPS2390	Simple -48-V telecom	1	-36 to -80	1H			✓		✓		Current	No	8-pin MSOP	1.00
TPS2391	Simple -48-V telecom	1	-36 to -80	1H			✓			✓	Current	No	8-pin MSOP	1.00
TPS2392	Full featured -48-V telecom	1	-20 to -80	1H	✓	✓	✓	✓	✓		Current	No	14-pin TSSOP	1.35
TPS2393	Full featured -48-V telecom	1	-20 to -80	1H	✓	✓	✓	✓		✓	Current	No	14/44-pin TSSOP	1.35
TPS2393A	Full featured -48-V telecom (Fast retry)	1	-20 to -80	1H	✓	✓	✓	✓		✓	Current	No	14-pin TSSOP	1.35
TPS2394	Full featured, ESD ruggedized -48-V hotswap	1	-12 to -80	1H	✓	✓	✓	✓		✓	Current	No	14-pin TSSOP	1.35
TPS2395	-48-V hot swap with I ² C-based current monitor	1	-12 to -80	1H	✓	✓	✓	✓		✓	Current	No	20-pin TSSOP	TBD
TPS2398	Simple -48-V telecom with PG	1	-36 to -80	1H				✓	✓		Current	No	8-pin MSOP	1.35
TPS2399	Simple -48-V telecom with PG	1	-36 to -80	1H				✓		✓	Current	No	8-pin MSOP	1.35
TPS2400	Overvoltage/undervoltage protection IC	1	2 to 100	1H	✓	✓			✓		—	No	SOT-23-5	0.80
TPS2456	Inrush controller with reverse current control	2	8.5 to 15	2H	✓		✓	✓	✓		Current	No	36-pin QFN	3.75
TPS2458	xTCA mezzanine cards, general 12 V	1	8.5 to 15	1L	✓		✓	✓	✓		Current	No	32-pin QFN	2.00
TPS2459	xTCA mezzanine cards, general 12 V	1	8.5 to 15	1H/1L	✓	✓	✓	✓	S ¹	S ¹	Current	No	32-pin QFN	2.50
TPS24700	Industrial, mass storage, servers, telecom	1	2.5 to 18	1H	✓			✓	✓		Current	No	8-pin MSOP	1.10
TPS24701	Industrial, mass storage, servers, telecom	1	2.5 to 18	1H	✓			✓	✓	✓	Current	No	8-pin MSOP	1.10

¹S = Selectable.

*Suggested resale price in U.S. dollars in quantities of 1,000.

New devices are listed in bold red. Preview devices are listed in bold blue.

Power Protection and Control

→ Protection and Power Switches

Hot Swap Controllers (External FET) Selection Guide (Continued)

Device	Target Applications	Channels	V _{IN} Range (V)	Enable/Shutdown	UV	OV	Fault	PG	Latch	Auto Retry	Ramp	Power Limiting	Package(s)	Price*
TPS24710	Industrial, mass storage, servers, telecom	1	2.5 to 18	1H	✓		✓	✓	✓		Current	Yes	10-pin MSOP	1.25
TPS24711	Industrial, mass storage, servers, telecom	1	2.5 to 18	1H	✓		✓	✓		✓	Current	Yes	10-pin MSOP	1.25
TPS24720	Industrial, mass storage, servers, telecom	1	2.5 to 18	1H	✓	✓	✓	✓	S ¹	S ¹	Current	Yes	16-pin SON	1.40
TPS2480	Servers, basestations, +48 V, +12 V	1	9 to 80	1H	✓			✓	✓		Current	Yes	20-pin TSSOP	3.00
TPS2481	Servers, basestations, +48 V, +12 V	1	9 to 80	1H	✓			✓		✓	Current	Yes	20-pin TSSOP	3.00
TPS2490	Servers, basestations, +48 V, +12 V	1	9 to 80	1H	✓			✓	✓		Current	Yes	10-pin MSOP	1.40
TPS2491	Servers, basestations, +48 V, +12 V	1	9 to 80	1H	✓			✓		✓	Current	Yes	10-pin MSOP	1.40
TPS2492	Servers, basestations, industrial, +48 V, +12 V	1	9 to 80	1H	✓	✓	✓	✓	✓		Current	Yes	14-pin TSSOP	1.45
TPS2493	Servers, basestations, industrial, +48 V, +12 V	1	9 to 80	1H	✓	✓	✓	✓		✓	Current	Yes	14-pin TSSOP	1.45

¹S = Selectable.

*Suggested resale price in U.S. dollars in quantities of 1,000.

New devices are listed in **bold red**. Preview devices are listed in **bold blue**.

ORing FET Controllers/MUX Devices Selection Guide

Device	Description	Channels	V _{IN} Range (V)	Enable/Shutdown	UV	OV	Fault	PG	ORing Linear Gate Drive?	On/Off ORing Function?	Package(s)	Price*
TPS2410	ORing FET controller/MUX controller	1	0.8 to 16.5	1H	✓	✓	✓	✓	✓		14-pin TSSOP	1.70
TPS2411	ORing FET controller/MUX controller	1	0.8 to 16.5	1H						✓		1.70
TPS2412	ORing FET controller	1	0.8 to 16.5						✓		8-pin SOIC, 8-pin TSSOP	1.20
TPS2413	ORing FET controller	1	0.8 to 16.5							✓	8-pin SOIC, 8-pin TSSOP	1.20
TPS2419	ORing FET controller with OV/enable	1	3 to 16.5	1H		✓				✓	8-pin SOIC	1.20
TPS2456	Inrush/reverse current controller for dual sources	2	8.5 to 15	2H	✓		✓	✓	✓		36-pin QFN	3.45
TPS2358	Dual 12-V/3.3-V hotswap/ORing controller	2	8.5 to 15	2L							48-pin QFN	4.00
TPS2359	Dual 12-V/3.3-V hotswap/ORing controller	2	8.5 to 15	Via I ² C							36-pin QFN	5.00

*Suggested resale price in U.S. dollars in quantities of 1,000.

New devices are listed in **bold red**.

→ Protection and Power Switches

The Integration/Size Advantage of Load Switches

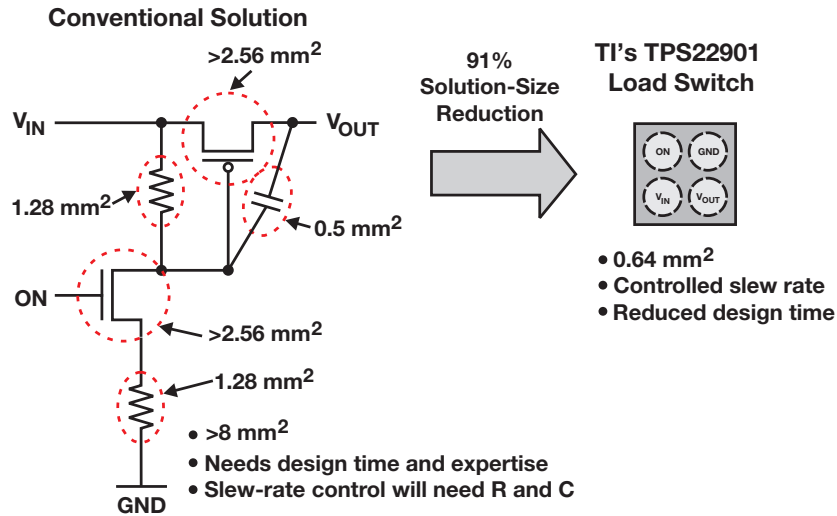

Portable Electronics Integrated Load Switches Product Portfolio

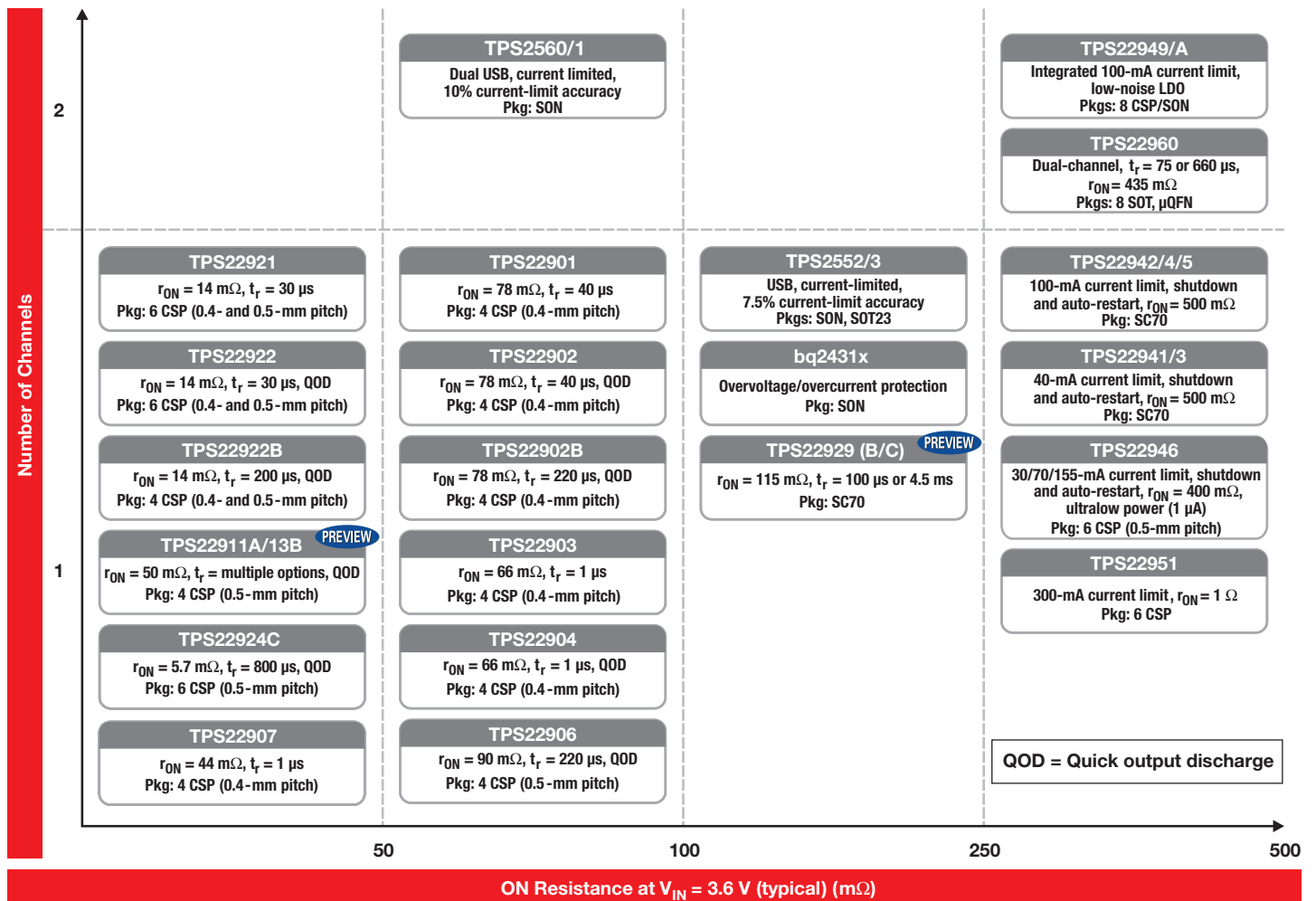

Non-Current-Limited Load Switches Product Portfolio

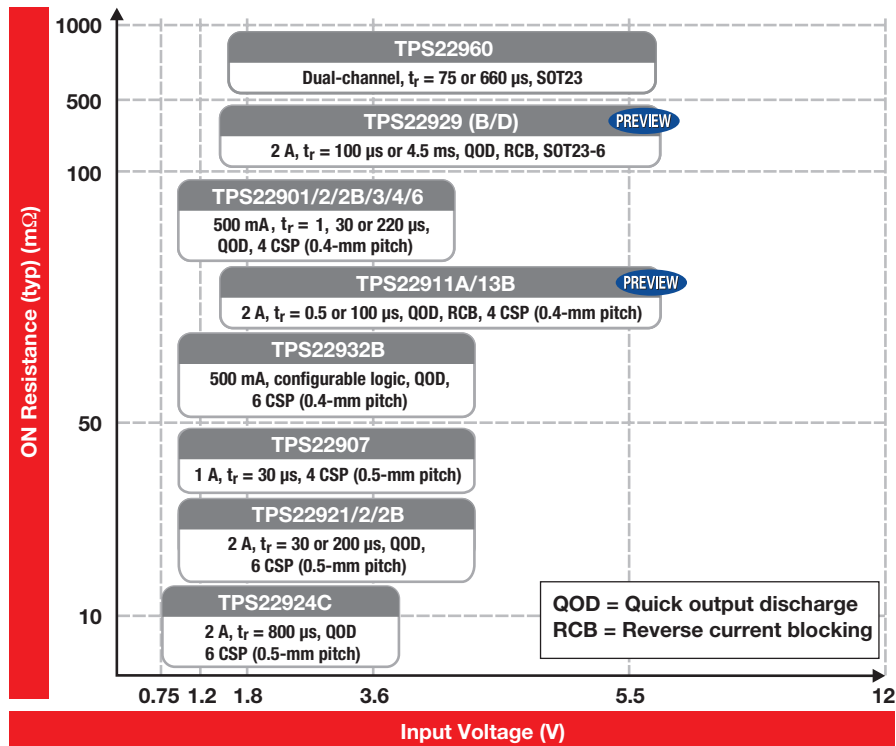

Selection Guide

Device	Input Voltage Range (V)	Number of Channels	r_{ON} at 3.6 V (mΩ)	Output Rise Time (μs)	Quick Output Discharge	Max Output Current	Enable	Package(s)	Price*
Non-Current-Limiting Load Switches									
TPS22901	1.0 to 3.6	1	78	40	No	500 mA	Active high	CSP (0.8x0.8 mm)	0.32
TPS22902	1.0 to 3.6	1	78	40	Yes	500 mA	Active high	CSP (0.8x0.8 mm)	0.32
TPS22902B	1.0 to 3.6	1	78	220	Yes	500 mA	Active high	CSP (0.8x0.8 mm)	0.32
TPS22903	1.1 to 3.6	1	66	1	No	500 mA	Active high	CSP (0.8x0.8 mm)	0.32
TPS22906	1.0 to 3.6	1	90	220	Yes	500 mA	Active high	CSP (0.9x0.9 mm)	0.32
TPS22907	1.1 to 3.6	1	44	36	No	1 A	Active high	CSP (0.9x0.9 mm)	0.38
TPS22913B	1.4 to 5.5	1	50	100	Yes	2 A	Active high	CSP (0.9x0.9 mm)	TBD
TPS22921	0.9 to 3.6	1	14	30	No	2 A	Active high	CSP (0.8x1.2 mm or 0.9x1.4 mm)	0.43
TPS22922	0.9 to 3.6	1	14	30	Yes	2 A	Active high	CSP (0.8x1.2 mm or 0.9x1.4 mm)	0.43
TPS22922B	0.9 to 3.6	1	14	200	Yes	2 A	Active high	CSP (0.8x1.2 mm or 0.9x1.4 mm)	0.43
TPS22924C	0.75 to 3.6	1	6	800	Yes	2 A	Active high	CSP (0.9x1.4 mm)	0.55
TPS22929B	1.4 to 5.5	1	110	100	Yes	2 A	Active high	SOT23-6 (3x3 mm)	TBD
TPS22929D	1.4 to 5.5	1	110	4500	Yes	2 A	Active high	SOT23-6 (3x3 mm)	TBD
TPS22932B	1.1 to 3.6	1	55	165	Yes	500 mA	Configurable	CSP (0.8x1.2 mm)	0.55
TPS22960	1.62 to 5.5	2	435	75 or 660	Yes	500 mA	Active high	SOT23-8 (3x3 mm), μQFN (1.5x1.5 mm)	0.42

Device	Input Voltage Range (V)	r_{ON} at 1.8 V (Ω)	Current Limit (mA)	Current-Limit Blanking Time (ms)	Auto-Restart Time (ms)	Active	Package(s)	Price*
Current-Limiting Load Switches								
TPS22941	1.62 to 5.5	1.1	40	10	80	Low	5 SC70	0.42
TPS22942	1.62 to 5.5	1.1	100	10	80	Low	5 SC70	0.42
TPS22943	1.62 to 5.5	1.1	40	0	—	High	5 SC70	0.42
TPS22944	1.62 to 5.5	1.1	100	0	—	High	5 SC70	0.42
TPS22945	1.62 to 5.5	1.1	100	10	80	High	5 SC70	0.42
TPS22946	1.62 to 5.5	0.6	155/70/30	10	70	High	6 CSP	0.55
TPS22949	1.62 to 4.5	1	100	12	70	High	8 CSP	0.70
TPS22949A	1.62 to 4.5	1	100	12	70	High	8 CSP/SON	0.70
TPS22951	2.8 to 5.3	1	600	—	—	High	6 CSP	0.45

*Suggested resale price in U.S. dollars in quantities of 1,000.

Preview devices are listed in **bold blue**.

→ Protection and Power Switches

USB Current-Limiting Power Switches

Power switches are used to intelligently turn power on/off and provide fault protection. They are ideal for power sequencing or segmentation and when controlled allocation of power is needed to circuit blocks, modules, add-in cards or cabled connections.

Universal Serial Bus (USB) ports are great examples of where this intelligent protection is vital for protecting your power supply and achieving regulatory compliance. TI's family of low-cost power switches are ideal for USB port designs.

To minimize voltage drop, select devices with the lowest $r_{DS(on)}$ or drain-to-source on-resistance.

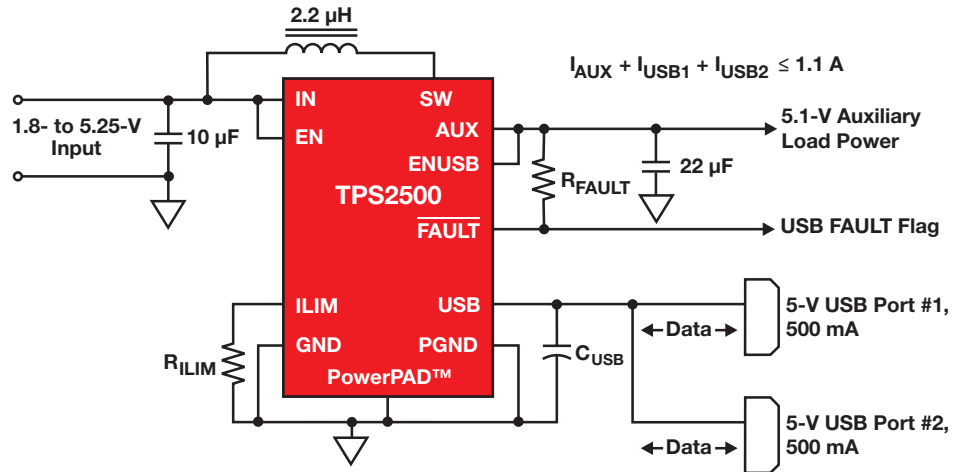

The TPS2500/1 combines a boost converter and a current-limiting switch for USB applications where the 5-V rail is not available. It is also ideal for devices with 1.8-V, 2.5-V or 3.3-V rails.

Current-Limited Switch Matrix

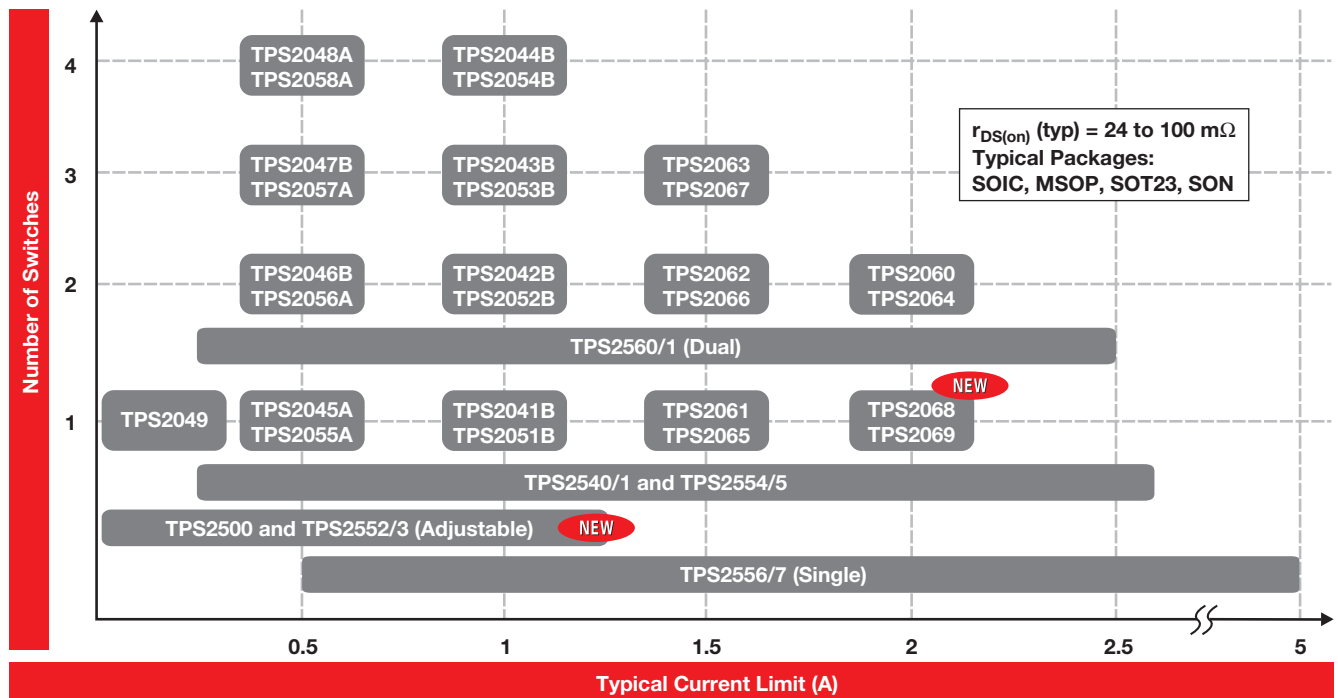

→ Protection and Power Switches

USB Mobile Device Charging

What is “universal charging”?

Consumers have long desired a universal device to charge their many mobile electronic devices. Governments (like the European Union and China) and industry groups around the world are now moving to provide just such a framework, with three goals:

1. Provide a universal form factor—the USB interface (Standard-A plug to Micro-B plug)
2. Minimize environmental impact by reducing electronics waste and no-load power consumption
3. Reduce charging times when possible

Consumers will soon expect all USB host ports to be able to charge their devices. So, if your design calls for a USB port, you may want to comply with this standard in your next product release. Common products for which consumers may want a USB charging port include LCD TVs, set-top boxes, notebook/desktop PCs and dedicated charging AC adapters. For all of these devices, the TPS2540/1 may be ideal.

The TPS2540 takes the standard USB power switch (see page 82 for our full portfolio) and combines it with the special data signaling required to comply with Universal Charger Solution (UCS) requirements. This makes it possible for a USB port to quickly charge UCS-compliant devices and even many popular, proprietary devices that predate the standard (such as Apple devices). All this is accomplished without any special software.

The TPS2540/1 are fully released. Order an evaluation board or some samples today!

Battery Charging 1.2 (BC 1.2)

BC 1.2 defines the type of charger, handshaking, allowable current draws, and PD decision-making flowchart that defines the interaction between PD and the host charger.

BC 1.2 Port Type	Definition	5-V Current Capability
Standard Downstream Port (SDP)	Compliant USB 2.0 port. No special charging capability	Up to 500 mA
Dedicated Charging Port (DCP)	Wall charger. No data communication capability	Up to 1.5 A
Charging Downstream Port (CDP)	A USB 2.0 compliant port with intelligent charging capability	Up to 500 mA if authenticated as SCP or up to 1.5 A if authenticated as CDP

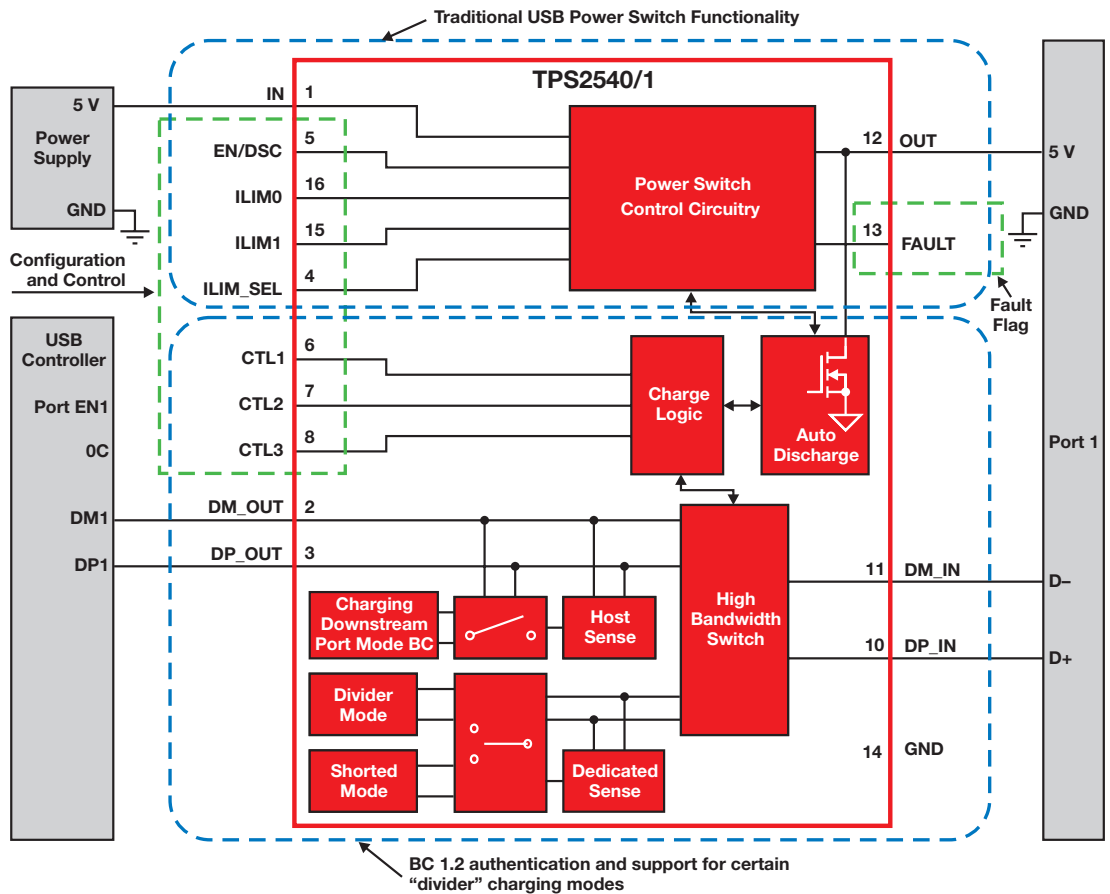

The TPS2540/1 incorporates a traditional USB power switch and the BC 1.2 intelligence for universal charging negotiation.

TPS2540/1 Comparison

Device	Identical Pinouts	Functionality	Applications Impact	Ideal Applications
TPS2540	Pin 5 is EN.	Output discharge requires all CTL pins to be low and separate from Enable control.	Discharging voltage on output caps is important during renegotiation. When a power adapter is added or removed, power should be renegotiated.	Notebook PCs or mobile devices.
TPS2541	Pin 5 is DSC.	Output discharge functionality and Enable control in one pin, the DSC.	A simple device, like an AC adapter, may not have much I/O available.	Dedicated chargers or anything with I/O constraints.

→ Protection and Power Switches

USB Current-Limiting Switches Selection Guide

Device	Number of FETs	I _{OS} (min) (A)	r _{DS(on)} (mΩ)	V _{IN} Range (V)	Supply Current (μA)	OC Logic Output	OT Logic Output	Enable	Predecessor	Price*
TPS2010A	1	0.22	30	2.7 to 5.5	73	No	No	L	TPS2010	0.75
TPS2011A	1	0.66	30	2.7 to 5.5	73	No	No	L	TPS2011	0.75
TPS2012A	1	1.1	30	2.7 to 5.5	73	No	No	L	TPS2012	0.75
TPS2013A	1	1.65	30	2.7 to 5.5	73	No	No	L	TPS2013	0.75
TPS2020/30	1	0.22	33	2.7 to 5.5	73	Yes	Yes	L/H	—	0.90
TPS2021/31	1	0.66	33	2.7 to 5.5	73	Yes	Yes	L/H	TPS2014	0.90
TPS2022/32	1	1.1	33	2.7 to 5.5	73	Yes	Yes	L/H	TPS2015	0.90
TPS2023/33	1	1.65	33	2.7 to 5.5	73	Yes	Yes	L/H	—	0.90
TPS2024/34	1	2.2	33	2.7 to 5.5	73	Yes	Yes	L/H	—	0.90
TPS2041B/51B	1	0.7	70	2.7 to 5.5	43	Yes	Yes	L/H	TPS2041/51/41A/51A	0.50
TPS2042B/52B	2	0.7 ea	70	2.7 to 5.5	50	Yes	Yes	L/H	TPS2042/52/42A/52A	0.70
TPS2043B/53B	3	0.7 ea	70	2.7 to 5.5	65	Yes	Yes	L/H	TPS2043/53/43A/53A	0.90
TPS2044B/54B	4	0.7 ea	70	2.7 to 5.5	75	Yes	Yes	L/H	TPS2044/54/44A/54A	1.10
TPS2045A/55A	1	0.3	80	2.7 to 5.5	80	Yes	Yes	L/H	TPS2045/55	0.60
TPS2046B/56A	2	0.3 ea	80	2.7 to 5.5	80	Yes	Yes	L/H	TPS2046/46A/56	0.70
TPS2047B/57A	3	0.3 ea	80	2.7 to 5.5	160	Yes	Yes	L/H	TPS2047/47A/57	1.00
TPS2048A/58A	4	0.3 ea	80	2.7 to 5.5	160	Yes	Yes	L/H	TPS2048/58	1.20
TPS2049	1	0.1	400	2.7 to 5.5	43	Yes	Yes	L	TPS2041/51/41A/51A	0.55
TPS2540/41	1	0.25 to 2.8	73	4.5 to 5.5	150	Yes	Yes	H	—	0.90
TPS2552/53	1	0.75 to 1.3	85	2.5 to 6.5	120	Yes	Yes	L/H	—	0.75
TPS2552-1/53-1	1	0.75 to 1.3	85	2.5 to 6.5	120	Yes	Yes	L/H	—	0.75
TPS2554/55	1	0.25 to 2.8	73	4.5 to 5.5	150	Yes	Yes	H/L	—	0.80
TPS2556/57	1	0.5 to 5	24	2.5 to 6.5	130	Yes	Yes	L/H	—	0.90
TPS2560/61	2	0.25 to 2.5	48	2.5 to 6.5	130	Yes	Yes	L/H	—	0.90
TPS2590	1	1 to 5	28	3 to 20	35	Yes	No	L	—	1.05
TPS2060/4	2	1.5 ea	70	2.7 to 5.5	50	Yes	Yes	L/H	—	1.00
TPS2061/5	1	1.1	70	2.7 to 5.5	43	Yes	Yes	L/H	—	0.60
TPS2062A/6	2	1.1 ea	70	2.7 to 5.5	50	Yes	Yes	L/H	TPS2062	0.75
TPS2063/7	3	1.1 ea	70	2.7 to 5.5	65	Yes	Yes	L/H	—	0.90
TPS2068/9	1	1.5	70	2.7 to 5.5	43	Yes	Yes	L/H	—	0.75
TPS2080/1/2 ¹	2	0.7 ea	80	2.7 to 5.5	85	Yes	Yes	2H, 1L/1H, 2L	—	0.65
TPS2085/6/7 ¹	4	0.7 ea	80	2.7 to 5.5	85	Yes	Yes	4H, 2L/2H, 4L	—	1.05
TPS2090/1/2 ¹	2	0.3 ea	80	2.7 to 5.5	85	Yes	Yes	2H, 1L/1H, 2L	—	0.65
TPS2095/6/7 ¹	4	0.3 ea	80	2.7 to 5.5	85	Yes	Yes	4H, 2L/2H, 4L	—	1.05

¹ Can be configured as power MUX ICs.

*Suggested resale price in U.S. dollars in quantities of 1,000.

New devices are listed in bold red. Preview devices are listed in bold blue.

Power Multiplexers and ExpressCard™ Power Switches

Power MUX ICs are designed to transition from a main power supply to an auxiliary source when the main supply

shuts down (e.g., switching from battery operation to a wall adapter).

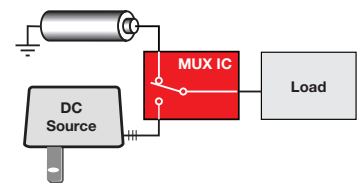

Selection Guide

Device	Number of Inputs	IN1 r _{DS(on)} (mΩ)	IN2 r _{DS(on)} (mΩ)	IN1 Output Current (mA)	IN2 Output Current (mA)	IN1 Supply Current (μA)	IN2 Supply Current (μA)	Input Voltage Range (V)	Transition Time		Transition	Price*
									IN1 to IN2 (μs)	IN2 to IN1 (μs)		
TPPM0301/2	3	—	—	400	400	2500	250	3 to 5.5	—	—	Autoswitch	1.60
TPPM0303	3	—	—	250	250	2500	250	3 to 5.5	—	—	Autoswitch	1.07
TPS2100/1	2	250	1300	500	10	10	0.75	2.7 to 4.0	4	900	L/H enable	0.59
TPS2102/3	2	250	1300	500	100	14	0.75	2.7 to 4.0	3	700	L/H enable	0.69
TPS2104/5	2	250	1300	500	100	18	0.75	2.7 to 5.5	3	700	L/H enable	0.85
TPS2110A/2A/4A	2	120	120	312 to 750	312 to 750	85	85	2.8 to 5.5	40	40	Autoswitch	0.70
TPS2111A/3A/5A	2	84	84	625 to 1250	625 to 1250	85	85	2.8 to 5.5	40	40	Autoswitch	0.70

*Suggested resale price in U.S. dollars in quantities of 1,000.

→ Voltage Supervisors and Digital Sequencers

Design Factors

Manual Reset (MR) — This feature allows the user to manually reset the circuit or control the supervisory circuit by another device of the application.

Watchdog Input (WDI) — In situations where the system processor may not be functioning properly, its onboard watchdog feature may fail to reset. Supervisors with integrated watchdog functionality increase system reliability by being able to trigger a reset.

Active High Output — Allows the use of processors with active high reset input without additional components.

Delay Time — Allows the voltage and other components in the circuit to stabilize first before the normal operation starts again.

Open Collector — Same as open drain, but the RESET output is connected to the collector of the internal transistor.

Open Drain — The RESET output of the supervisory circuit is connected to the drain of the internal MOSFET. Choose an open-drain reset output supervisor when more than one supervisor is connected on the bus.

Push-Pull — A push-pull reset output supervisor is recommended when only one supervisor is needed on the bus. This eliminates the need for a pull-up resistor and offers higher speed.

Quad Supervisor with Programmable Delay and Watchdog Timer

NEW

TPS386000/20/40/60

Get samples at: www.ti.com/sc/device/TPS386000

The TPS3860xx family can monitor four power rails that are greater than 0.4 V with a 0.25% threshold accuracy. With external resistors, the threshold of each SVS can be programmed. Each SVS has a programmable delay circuit, and the delay time can be set from 1.25 ms to 10 s. The quiescent current is very low with 12 µA (typical). Available in a small 4x4-mm, 20-pin QFN package. Options:

- TPS386000: Open-Drain $\overline{\text{RESET}}$ and $\overline{\text{WDO}}$
- TPS386020: Open-Drain $\overline{\text{RESET}}$ and $\overline{\text{WDO}}$
- TPS386040: Push-Pull $\overline{\text{RESET}}$ and $\overline{\text{WDO}}$
- TPS386060: Push-Pull $\overline{\text{RESET}}$ and $\overline{\text{WDO}}$

Supervisory Circuits, Reset ICs and Sequencers Family of Products

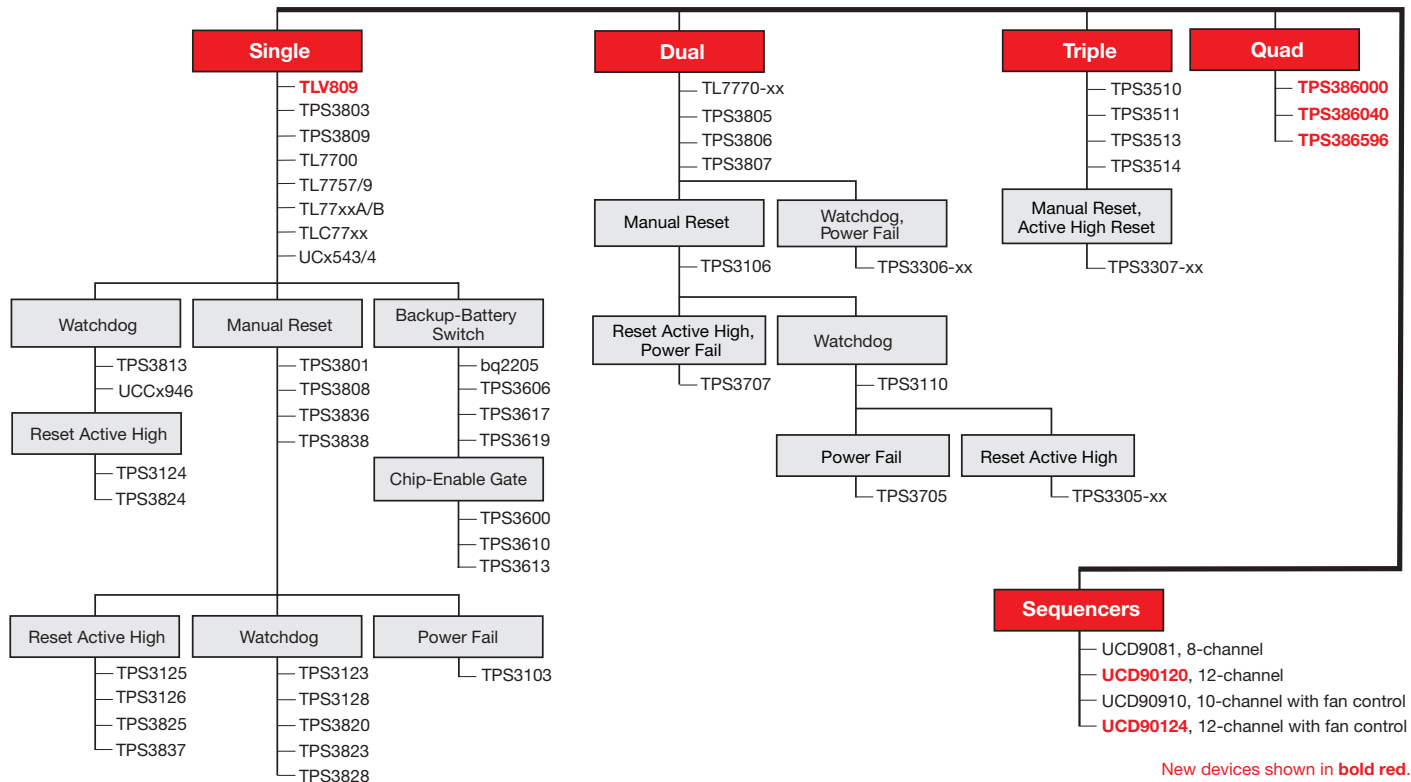

➔ Voltage Supervisors and Digital Sequencers

Power-Supply Sequencer

UCD90120/4

Get samples at: www.ti.com/sc/device/UCD90120

The UCD90120/4 Power Supply Sequencer and System Health Controller sequences up to 12 independent voltage rails. The devices integrate a 12-bit, 200-kcps ADC with a 1% accurate internal reference for monitoring up to 13 inputs for power supply voltage, current, or temperature. There are 26 GPIO pins that can be used for power supply enables, power-on reset signals, or other system functions. Also, 12 of the 26 GPIO pins can be used as PWM outputs for power supply margining, fan control (UCD90124 only), or general-purpose PWM functions including multiphase clock generation for switch-mode power supplies. Both devices offer non-volatile fault logging for capturing power supply faults, peak rail voltages, and other important data that can aid in system failure analysis. JTAG and PMBus™ interfaces provide options for preproduction and in-system configuring and monitoring. The TI Fusion Digital Power™ Designer is provided for device configuration. This PC-based graphical user interface offers an intuitive interface for configuring, storing, and monitoring all system operating parameters.

Features

Sequence

- Sequence up to 12 rails on and off
- Dependencies on time, parent rails, GPIOs, and I²C

- Independent turn-on and turn-off configurations
- Flexible GPIO for enables, power goods, and more
- Boolean logic builder

Monitor

- Respond to faults by configuring retries, shutdown delays, and slave rails to shutdown
- User settable scale factors convert to actual system units including voltage, current, and temperature
- 6 optional comparators for fault response in < 60 μs

- Nonvolatile fault logging

Margin

- Simultaneously margin up to 10 rails using PWM outputs
- Support for open-loop or closed-loop methods
- Command rails high and low using I²C or GPIO pins
- All unused margining outputs can be used as GPIO

Fan control (UCD90124 only)

- Monitor and control up to 4 fans (2-, 3-, or 4-wire fans)

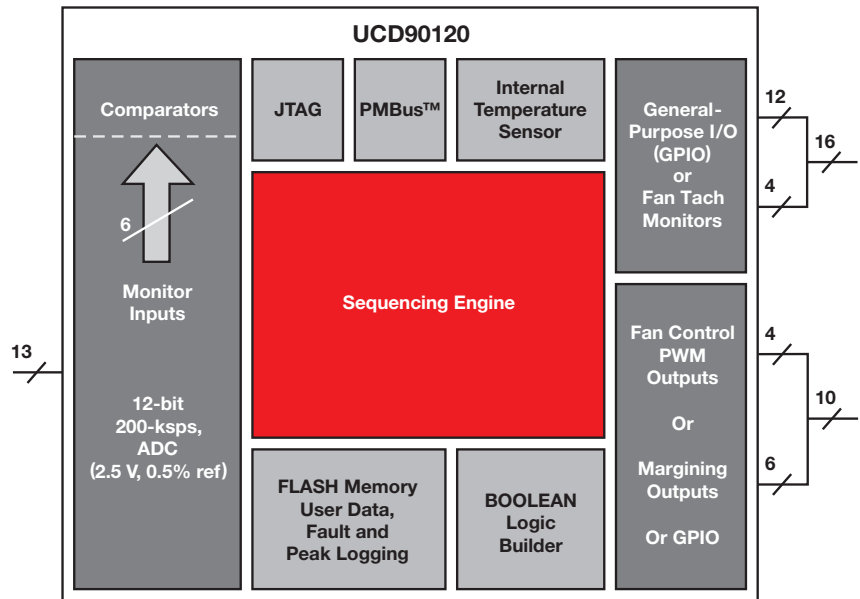

Typical application for UCD90120 sequencer.

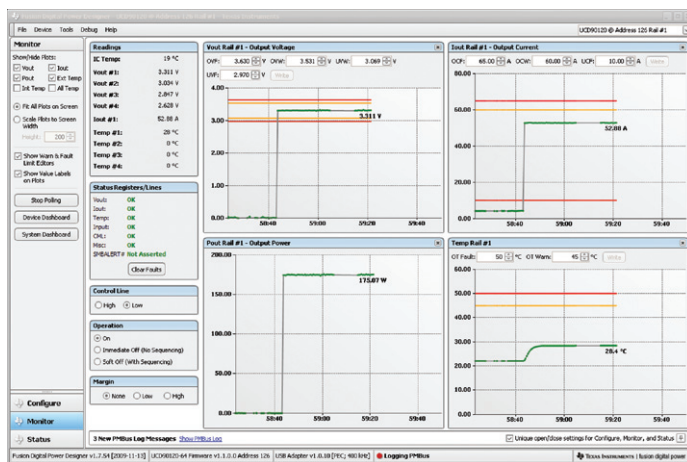

Monitoring.

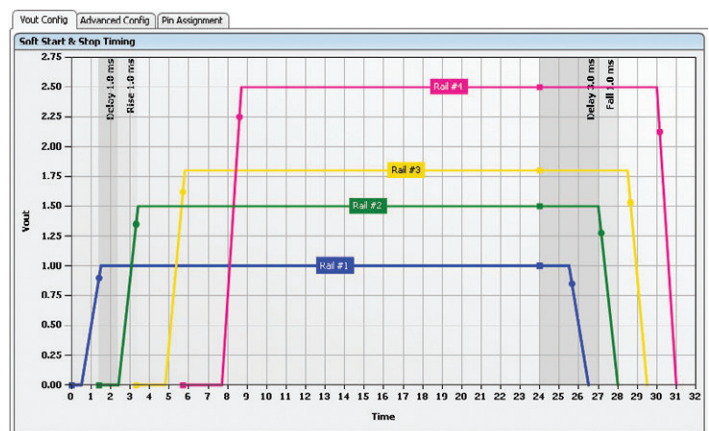

Sequencing.

→ Voltage Supervisors and Digital Sequencers

Selection Guide

Device	Number of Supervisors	Supervised Voltages	Package(s)	V _{DD} Range (V)	I _{DD} (typ) (µA)	Time Delay (ms)	Watchdog Timer WDI (sec)	Reset Threshold Accuracy (%)	Manual Reset Input/MR	Active-Low Reset Output	Active-High Reset Output	Reset Output Topology ¹	Power-Fail PFI/PFO	Overvoltage Detection	Overcurrent Detection	Backup-Battery Switchover	Chip-Enabled Gating	HiRel (H) or Automotive (A) [†]	Comments	Price*
General Purpose Supply Supervisors																				
TPS3808	1	Adj./0.9/1.2/1.5/1.8/2.5/3.0/3.3/5.0/EEPROM	SOT-23, SON-6	1.8 to 6.5	2.4	Prog	—	0.5	✓	✓		OD						H, A		0.70
TPS3818	1	2.5/EEPROM	SOT-23, SON-6	1.8 to 6.5	2.4	Prog	—	0.5	✓	✓		OD							High accuracy delay	0.95
TPS3103	1	1.2/1.5/2.0/3.3	SOT-23	0.4 to 3.3	1.2	130	—	0.75	✓	✓		OD	✓							0.90
TPS3123	1	1.2/1.5/1.8	SOT-23	0.75 to 3.3	14	180	1.4	3.6	✓	✓		PP								0.85
TPS3124	1	1.2/1.5/1.8	SOT-23	0.75 to 3.3	14	180	1.4	3.6	✓	✓	✓	PP								0.85
TPS3125	1	1.2/1.5/1.8/3.0	SOT-23	0.75 to 3.3	14	180	—	3.6	✓	✓	✓	PP								0.80
TPS3126	1	1.2/1.5/1.8	SOT-23	0.75 to 3.3	14	180	—	3.5	✓	✓	✓	OD								0.80
TPS3128	1	1.2/1.5/1.8	SOT-23	0.75 to 3.3	14	180	1.4	3.5	✓	✓		OD								0.85
TPS3800	1	2.7	SC-70	1.6 to 6.0	9	100	—	2	✓	✓		PP								0.40
TPS3801	1	Adj./1.8/2.5/3.0/3.3/5.0	SC-70	1.6 to 6.0	9	200	—	2	✓	✓		PP								0.40
TPS3802	1	3.0/3.3	SC-70	1.6 to 6.0	9	400	—	2	✓	✓		PP								0.40
TPS3803	1	Adj./1.5	SC-70	1.3 to 6.0	3	—	—	1.5	✓	✓		OD						H, A	Voltage detector	0.25
TPS3809	1	2.5/3.0/3.3/5.0	SOT-23	2.0 to 6.0	9	200	—	2.2		✓		PP						H, A		0.25
TLV809	1	2.5/3.0/3.3/5.0	SOT-23	2.0 to 6.0	9	200	—	2.2		✓		PP								0.25
TPS3813	1	2.5/3.0/3.3/5.0	SOT-23	2.0 to 6.0	9	25	Window	2.2		✓		OD						H, A	Window watchdog	0.90
TPS3820/8-xx	1	3.3/5.0	SOT-23	1.1 to 5.5	15	25/200	0.2/1.6	2.4	✓	✓		PP/OD						A		0.65
TPS3823	1	2.5/3.0/3.3/5.0	SOT-23	1.1 to 5.5	15	200	1.6	2.4	✓	✓		PP						A		0.65
TPS3824-xx	1	2.5/3.0/3.3/5.0	SOT-23	1.1 to 5.5	15	200	1.6	2.2		✓	✓	PP						A		0.65
TPS3825-xx	1	3.3/5.0	SOT-23	1.1 to 5.5	15	200	—	2.2	✓	✓	✓	PP						A		0.55
TPS3836/8	1	1.8/2.5/3.0/3.3	SOT-23	1.6 to 6.0	0.22	10/200	—	2.5	✓	✓		PP/OD						H, A		0.85
TPS3837	1	1.8/2.5/3.0/3.3	SOT-23	1.6 to 6.0	0.22	10/200	—	2.4	✓		✓	PP						H, A		0.85
TL7700	1	Adjustable	DIP-8, SOP-8	1.8 to 40	0.6 mA	Prog	—	1		✓		OC								2.25
TL77xxA/B	1	2.7/3.3/5.0/9/12/15	SO-8, DIP-8, SOP-8	3.5 to 18	1.8 mA	Prog	—	2	✓	✓	✓	OC						H		0.25
TLC77xx	1	Adj./2.5/3.3/3.0/5.0	SO-8, DIP-8, TSSOP-8	2.0 to 6.0	9	Prog	—	5.5		✓	✓	PP						H, A		0.65
UCCx946	1	Adjustable	SO-8, DIL-8, TSSOP-8	2.0 to 5.5	10	Prog	Prog	2		✓		PP						A		1.75
TPS3807	2	3/3.5	SC-70	1.8 to 6.5	3.5	20	—	1		✓		OD								0.95
TPS3106	2	Adj./0.9/1.6/3.3	SOT-23	0.4 to 3.3	1.2	130	—	0.75	✓	✓		OD						H		0.90
TPS3110	2	Adj./0.9/1.2/1.5/3.3	SOT-23	0.4 to 3.3	1.2	130	1.1	0.75	✓	✓		PP								0.99
TPS3305-xx	2	1.8/2.5/3.3/5.0	SO-8, MSOP-8	2.7 to 6.0	15	200	1.6	2.7	✓	✓	✓	PP								1.00
TPS3306-xx	2	1.5/1.8/2.0/2.5/3.3/5.0	SO-8, MSOP-8	2.7 to 6.0	15	100	0.8	2.7		✓		OD	✓					A		1.05
TPS3705-xx	2	3.0/3.3/5.0	SO-8, MSOP-8	2.0 to 6.0	30	200	1.6	2.1	✓	✓		PP	✓							0.80
TPS3707-xx	2	2.5/3.0/3.3/5.0	SO-8, MSOP-8	2.0 to 6.0	20	200	—	2.2	✓	✓	✓	PP	✓							0.75
TPS3805	2	Adj./3.3	SC-70	1.3 to 6.0	3	—	—	1.5		✓		PP						H, A	Voltage detector	0.34
TPS3806	2	Adj./2.0/3.3	SOT-23	1.3 to 6.0	3	—	—	2		✓		OD							Voltage detector	0.45
TL7770-xx	2	5.0/12.0 & Adj.	SO-16, DIP-16	3.5 to 18	5 mA	Prog	—	2	✓	✓	✓	OC		✓						1.55
TPS3307-xx	3	Adj./1.8/2.5/3.3/5.0	SO-8, MSOP-8	2.0 to 6.0	15	200	—	2.7	✓	✓	✓	PP						A		1.05
TPS386596	4	Adj./3.0	MSOP-8	1.8 to 6.5	7.5	Prog	—	0.25	✓	✓	✓	OD		✓						1.25
TPS3860x0	4	Adj. (includes negative rail)	QFN	1.8 to 6.5	9	Prog	0.6	0.25	✓	✓	✓	PP/OD	✓							1.95
UCD9081	8	Prog. by software GUI	QFN-32	3.3	3 mA	Prog														3.20
UCD90120	13	Prog. by software GUI	QFN-64	3.3 to 12	50 mA	Prog														4.95
UCD90124	13	Prog. by software GUI	QFN-64	3.3 to 12	50 mA	Prog														6.45
Battery Backup Switchover Supply Supervisors																				
TPS3600	1	2.0/2.5/3.3/5.0	TSSOP-14	1.6 to 5.5	20	100	0.8	2.3	✓	✓		PP	✓			✓	✓			2.15
TPS3606-33	1	3.3	MSOP-10	1.6 to 5.5	20	100	0.8	2	✓	✓		PP	✓			✓	✓			1.45
TPS3610	1	1.8/5.0	TSSOP-14	1.6 to 5.5	20	100	0.8	2		✓		PP	✓			✓	✓			1.80
TPS3613-01	1	Adjustable	MSOP-10	1.6 to 5.5	20	100	—	1.7	✓	✓	✓	PP				✓	✓			1.50
TPS3619	1	3.3/5.0	MSOP-8	1.6 to 5.5	15	100	—	2	✓	✓		PP	✓			✓	✓	H		1.10
Special Function Supply Supervisors																				
TPS3510/1	3	3.3/5.0/12.0	SO-8, DIP-8	4 to 15	1 mA	300	—	9.1		✓		OD	✓	✓					PC power supplies	0.45
TPS3513/4	3	3.3/5.0/12.0	SO-14, DIP-14	4.5 to 15	1 mA	300	—	9.1		✓		OD	✓	✓	✓				PC power supplies	0.70

¹PP = push-pull, OD = open drain, OC = open collector.

²3.3-V SRAM controller with battery backup.

[†]Devices qualified for HiRel (H) or Automotive (A) applications are available.

Certain voltage options are not available. Different pricing may apply.

*Suggested resale price in U.S. dollars in quantities of 1,000.

Note: Custom voltages can be provided. Minimum order quantities may apply. Contact TI for details and availability.

New devices are listed in bold red.

→ White LED Backlight, High-Current LED and Camera LED Flashlight Drivers

Design Factors

Series or Parallel LED Configuration

— Drives the driver topology. Inductive boost converters provide the necessary high voltage to a series LED string. This requires only one current regulation loop and two connection points for the LED string.

Charge pumps typically drive parallel LEDs; but unless each LED is current-regulated, each leg requires a current-set resistor.

Current Regulation — Avoids brightness variations in LED strings or legs that consist of LEDs with different forward voltages (V_f).

Overvoltage Protection (OVP) —

Protects the inductive driver from destruction in case faulty LEDs open the LED string.

Dimming — LED drivers typically feature analog and/or digital dimming to adjust the LED brightness.

LED and OLED Drivers Function Guide

	20	30	40	60
Multichannel		TPS61150/1 ~14 WLEDs, 2 x 35 mA, $V_{OUT(max)} = 27\text{ V}$, $V_{IN} = 2.5\text{ to }6.0\text{ V}$	TPS61185 NEW ~80 WLEDs, 8 x 25 mA, $V_{OUT(max)} = 38\text{ V}$, $V_{IN} = 4.2\text{ to }24\text{ V}$	TPS61199 NEW ~120 WLEDs, 8 x 80 mA, $V_{OUT(max)} = 60\text{ V}$, $V_{IN} = 4.5\text{ to }21\text{ V}$
			TPS61183 NEW ~80 WLEDs, 6 x 30 mA, $V_{OUT(max)} = 38\text{ V}$, $V_{IN} = 4.5\text{ to }24\text{ V}$	TPS61195 NEW ~96 WLEDs, 8 x 30 mA, $V_{OUT(max)} = 45\text{ V}$, $V_{IN} = 4.5\text{ to }21\text{ V}$
			TPS61180 ~60 WLEDs, 6 x 25 mA, $V_{OUT(max)} = 38\text{ V}$, $V_{IN} = 5.0\text{ to }24\text{ V}$	
Single Channel	TPS61166 ~3s3p WLEDs, 300 mA, $V_{OUT(max)} = 18\text{ V}$, $V_{IN} = 2.5\text{ to }10\text{ V}$	TPS61062 ~5 WLEDs, 25 mA, $V_{OUT(max)} = 23\text{ V}$, $V_{IN} = 2.7\text{ to }6.0\text{ V}$	TPS61500 ~12 WLEDs, 3.8 A, $V_{OUT(max)} = 38\text{ V}$, $V_{IN} = 2.9\text{ to }18\text{ V}$	
	TPS61060 ~3 WLEDs, 40 mA, $V_{OUT(max)} = 14\text{ V}$, $V_{IN} = 2.7\text{ to }6.0\text{ V}$	TPS61160 ~6 WLEDs, 20 mA, $V_{OUT(max)} = 26\text{ V}$, $V_{IN} = 2.7\text{ to }18\text{ V}$	TPS61165 ~27 WLEDs, 3s9p, 350 mA, $V_{OUT(max)} = 38\text{ V}$, $V_{IN} = 3.0\text{ to }18\text{ V}$	
	TPS61061 ~4 WLEDs, 30 mA, $V_{OUT(max)} = 18\text{ V}$, $V_{IN} = 2.7\text{ to }6.0\text{ V}$		TPS61161 ~10 WLEDs, 20 mA, $V_{OUT(max)} = 38\text{ V}$, $V_{IN} = 2.7\text{ to }18\text{ V}$	
	Overvoltage Protection, V_{OUT} Maximum (V)			

Special Applications

→ White LED Backlight, High-Current LED and Camera LED Flashlight Drivers

Selection Guide

Device	V _{IN} (V)	Synchronous	Type	Number of LEDs ¹	OLED Capable	LED Configuration	Switch Current Limit (typ) (mA)	Current Regulation	Overvoltage Protection (min) (V)	Output Capacitor	Load-Disconnect During Shutdown	Dimming ²	Peak Efficiency ³ (%)	Quiescent Current (typ) (mA)	Shutdown Current (typ) (µA)	Package(s)	HiRel (H) or Automotive (A) [†]	Price*
WLED Driver, Single Channel																		
TPS61041	1.8 to 6.0		Inductive	4		Series	250		No	1 µF		Yes	85	0.028	0.1	SOT-23	A	0.65
TPS61040	1.8 to 6.0		Inductive	6		Series	400		No	1 µF		Yes	86	0.028	0.1	SOT-23	A	0.65
TPS61043	1.8 to 6.0		Inductive	4		Series	400	✓	17	100 nF	✓	Yes	85	0.038	0.1	QFN-8		0.71
TPS61042	1.8 to 6.0		Inductive	6		Series	500	✓	28	100 nF	✓	Yes	85	0.038	0.1	QFN-8		0.75
TPS61045	1.8 to 6.0		Inductive	6	✓	Series	500	✓	28	100 nF	✓	Yes	85	0.038	0.1	QFN-8		0.90
TPS61166	2.5 to 6.0	✓	Inductive	5		Series	1100 ⁴	✓	19	4.7 µF	✓	Yes		1.5	1	QFN-10		1.35
TPS61160/A ⁶	2.7 to 18		Inductive	6		Series	700	✓	26	1 µF		1-pin	90	1.8	1	QFN-6		0.72
TPS61161/A ⁶	2.7 to 18		Inductive	10		Series	700	✓	38	1 µF		1-pin	90	1.8	1	QFN-6	A	0.76
TPS61165	3.0 to 18		Inductive	10 to 40		Series	1200	✓	38	1 µF		1-pin	90	2.3	1	QFN-6		1.10
TPS61060	2.7 to 6.0	✓	Inductive	3		Series	400	✓	14	220 nF		Yes	83	—	1	QFN-8/WCSP-8		0.85
TPS61061	2.7 to 6.0	✓	Inductive	4		Series	400	✓	18	220 nF		Yes	82	—	1	QFN-8/WCSP-8		0.90
TPS61062	2.7 to 6.0	✓	Inductive	5		Series	400	✓	22	220 nF		Yes	81	—	1	QFN-8/WCSP-8		0.97
TPS61080/1	2.5 to 6.0		Inductive	7	✓	Series	700/1300		27	4.7 µF	✓	No	94	1	1	QFN-10		1.35
TPS61500	2.9 to 18		Inductive	8		Series	3000	✓	35	4.7 µF		Yes	93	—	—	TSSOP-14		1.60
REG71050	3.2 to 5.5	—	Charge pump	3		Parallel	—	—	—	2.2 µF	—	No	92	0.065	0.01	SOT-23		0.55
TPS60230/1	2.7 to 6.5	—	Charge pump	5, 3		Parallel	—	✓	—	1 µF	—	Yes	85	0.200	0.1	QFN-16		0.55
TPS60250/5	2.7 to 6.0	—	Charge pump	7		Parallel	—	✓	—	4.7 µF	—	i ² C	—	6.7	1.3	QFN-16		0.90
TPS60251	2.7 to 6.0	—	Charge pump	7 + Aux		Parallel	—	✓	—	4.7 µF	—	i ² C	—	6.7	1.3	QFN-24		0.90
TPS75103/5	2.7 to 5.5	—	LDO	2 or 4		Parallel	—	✓	—	—	—	Yes	—	0.18	0.1	WCSP-9		0.65
TCA6507	1.65 to 3.6	—	Parallel	7		Parallel	—	—	—	—	—	—	—	—	—	WCSP-12/QFN-12		0.80
WLED Driver, Multichannel — Current Sink Implemented																		
TPS61140	2.5 to 6.0	✓	Inductive	4 + 1 OLED	✓	2 Series	2 x 550	✓	28	—		1-pin	82	2	1.5	QFN-10		1.16
TPS61150A	2.5 to 6.0	✓	Inductive	Up to 2 x 6		2 Series	2 x 550	✓	28	—		1-pin	83	2	1.9	QFN-10		1.16
TPS61183	4.5 to 24		Inductive	10 x 6		6 Series	2000	✓	38	10 µF		Yes	95	4	11	QFN-20		1.85
TPS61185	4.2 to 24		Inductive	10 x 8		8 Series	2000	✓	38	10 µF		Yes	94	<3	<10	QFN-24		1.80
TPS61195	4.5 to 21		Inductive	8 x 10		10 Series	3500	✓	50	10 µF		Yes	95	<3	<10	QFN-28		1.95
TPS61199⁵	8 to 30		Inductive	15 x 8		8 Series	5000	✓	60	3 x 33 µF		Yes	95	<1.5	<10	SOP-20/HTSSOP-20		1.85

¹ More LEDs can be driven in parallel string configuration.

² May be via ENABLE pin, CONTROL pin or analog feedback network.

³ Depends on LED current, input voltage, number of LEDs, ILED pin.

⁴ Output current is limited to 300 mA.

⁵ Controller. External FET needed.

⁶ "A" version does not have EasyScale™ interface.

[†] Devices qualified for HiRel (H) or Automotive (A) applications are available. Different pricing may apply.

*Suggested resale price in U.S. dollars in quantities of 1,000.

New devices are listed in bold red.

Device ¹	V _{IN} (V)	Max. Number of LEDs	Privacy LED	I _{OUT} (max) (mA)	Typical Switch Current (mA)	Super-Capacitor Support	Down Mode when V _{IN} > V _{OUT}	Control Interface	LED Temperature Monitoring	Power Save Mode	Battery Voltage-Droop Monitoring	Package(s)	Features and Differentiators	Total Solution Size (mm ²)	Price*
Camera Flash LED Drivers															
TPS61050/2	2.5 to 5.5	1	✓	1200	2000			i ² C				QFN-10, WCSP-12	Voltage-mode selection pin	25	1.00
TPS61054/5	2.5 to 5.5	1		700/500	1500/1000			Simple logic signal				QFN-10, WCSP-12		25	0.85
TPS61310	2.5 to 5.5	3	✓	1500	2000		✓	i ² C	✓	✓	✓	WCSP-20	HW-reset input, dual-wire camera-module interface, Power Good	25	1.55
TPS61325	2.5 to 5.5	3	✓	4100	1850	✓	✓	i ² C	✓	✓		WCSP-20	Dual-wire camera-module interface, super-capacitor balancing, flash ready output	25	1.70
TPS61300/1/5	2.5 to 5.5	3	✓	4100	1850	✓	✓	i ² C	✓	✓		WCSP-20	Voltage-mode selection pin (TPS61300/1) DC light-mode selection pin (TPS61300) Flash ready output, HW-reset input (TPS61301/5)	25	1.70

¹ All of these devices have TX-Mask and safety timer DC/Flash.

New devices are listed in bold red.

→ Design Support



The diagram features a central blue speech bubble icon containing a globe, a person, and a laptop. Below it, five red buttons labeled 'Analog', 'DSP', 'Microcontrollers', 'Applications', and 'Tools & Software' are arranged horizontally. Lines from these buttons converge on a central grey box listing training options: 'Online Training', 'Videocasts', 'Seminars', 'Conferences', '1-Day Workshops', and 'Multi-Day Workshops'. To the left, a 'Power Design' section describes TI's seminar series and provides the URL www.ti.com/powertraining. To the right, an 'Online Training and More' section describes available resources and also provides the same URL. At the bottom, there are images of a DLP projector, a 'Power Supply Design Seminar' brochure, and a computer workstation.

Training Options from TI

Analog **DSP** **Microcontrollers** **Applications** **Tools & Software**

Power Design

TI's popular Power Supply Design Seminar series and Portable Power Seminar series provide rich technical yet practical presentations that combine an array of advanced new power-management concepts, basic design principles and real-world applications examples. Seminar presenters are respected names in the power industry, drawing on decades of experience to discuss today's toughest design issues with innovative techniques, topologies, tools and examples. Keep this link handy to check on dates, times and locations of the Power Seminar series at: www.ti.com/powertraining

Online Training and More

You'll find past seminar topics as well as online training modules, videocasts, conferences, workshops and design tools to help you with your design challenges at: www.ti.com/powertraining

- Online Training
- Videocasts
- Seminars
- Conferences
- 1-Day Workshops
- Multi-Day Workshops

Power Supply Design Seminar

DLP



Resources

→ Design Support



Accelerating and simplifying the engineering process with highly integrated TI analog tools.

www.ti.com/analogelab

Online Power Supply Design Software for TPS40K™, TPS50K (SWIFT™), and TPS60K Controller Families

SwitcherPro™

www.ti.com/switcherpro

Features

- Develop solutions for buck and boost DC/DC controllers and converters
- Design internally and externally compensated high-performance power-supply designs
- Available online and downloadable
- Create and/or copy a design in about one minute using the Power Design Wizard
- Generate schematics and bill of materials for your design and view layout suggestions
- Calculate power-supply specs, losses and loop response
- Edit your designs, customize labels, access library with built-in components and add your own components
- Share your designs by using the design-report generation in pdf format

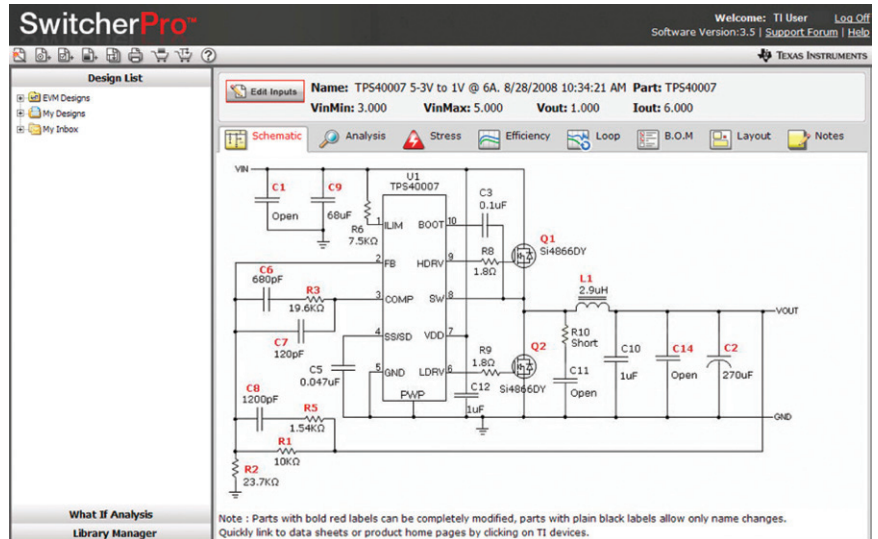

SPICE-Based Analog Simulation Program

TINA-TI™ version 7.0

www.ti.com/tina-ti

Features

- Easy-to-use, powerful, SPICE-based analog simulation program
- TINA-TI™ software is a fully functional version of TINA, loaded with a library of TI macromodels, including passive and active models
- Provides support for amplifiers and switching power-supply devices
- TINA-TI simulation software has no limits to circuit size, number of nodes or number of integrated circuits (ICs)
- Generates post-simulation results in tables and plots
- Built-in virtual oscilloscope, function generator and spectrum analyzer
- View all TINA-TI and Pspice™ models at www.ti.com/spicerack

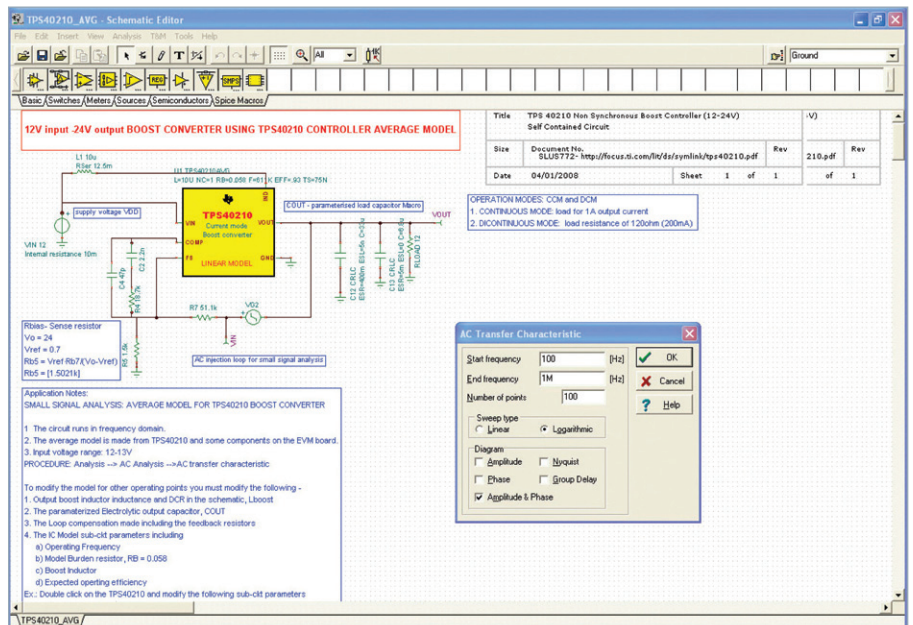

→ Packaging

Surface Mount Packages

	Package Type	Package Designator	Key Characteristics
Small Outline Packages			
	Small Outline Integrated Circuit (SOIC)	D, DW, DWU, DTH, DTC, DDA, DVB, DWP	High MSL rating* (MSL1/MSL2), variable size availability
	Mini Small Outline Package (MSOP)	DGK, DGS	Small form factor, thin package
	Heat Sink Small Outline Package (HSOP)	DWP, DWD	Thermally enhanced SOP (low to mid power)
	Small Shrink Outline Package (SSOP)	DL, DB, DF, DBQ, DCE, DCT	High MSL rating* (MSL1/MSL2), higher stand-off height
	Thin Shrink Small Outline Package (TSSOP)	DA, PW, DBT	Variable pin count options available, high MSL rating* (MSL1/MSL2), small form factor
	Exposed Pad Thin Shrink Small Outline Package (HTSSOP)	PWP, DAP, DAD, DCA	Thermally enhanced TSSOP (low to high power); various pin count options available
	Power Small Outline Package (PSOP3)	DKP (slug down), DKD (slug up)	Very high power handling capability, mechanically robust package
Quad Leaded Packages			
	Thin Quad Flat Pack (TQFP)	PFB, PAG, PJT, PBS, PAG	High pin count, leadframe based package
	Exposed Pad Thin Quad Flat Pack (HTQFP)	PAP, PJD, PZP, PHP, PNP, PHD	Thermally enhanced TQFP (mid to high power)
Small Outline Transistors			
	Small Outline Transistor (SC-70)	DCK	Mini form factor
	Small Outline Transistor Package (SOT23)	DBV, DCN, DDC, thin SOT	Small form factor, high MSL rating* (MSL1/MSL2)
	Small Outline Transistor (SOT223)	DCY, DCQ	High MSL rating* (MSL1/MSL2)
	Transistor Outline (TO236)	DBZ	Small form factor
Leaded Packages			
	Plastic Flange Mount Package (DDPak/TO-263)	KTT, KTW	Very high power handling capability
Leadless Packages			
	Small Outline No Leads (SON)	DRB, DRC, DRD, DRK, DRM, DRN, DRT, DSE, DSG, DSJ	Small footprint, thermal package (low to mid power)

*MSL rating should be checked for individual device.



Surface Mount Packages (Continued)

	Package Type	Package Designator	Key Characteristics
Leadless Packages (Continued)			
	Quad Flatpack No Leads (QFN)	RGC, RGE, RGF, RGP, RGT, RGW, RGY, RGZ, RHA, RHB, RHD, RHF, RHH, RHL, RSA, RSB, RSH, RSJ, RSL, RSM, RTE, RTH, RTQ, RTT, RUK, RUV, RVA	Compact footprint, thermal package (mid to high power), available in variable thicknesses
	Flip-Chip Power Packages	RSJ	High power handling capability
Ball Grid Arrays (BGAs)			
	Wafer Chip Scale Package (WCSP)/Die Sized Ball Grid Array (DSBGA)	YEG, YEK, YEJ, YEA, YZA, YED	Die size package, very small form factor, finer pitch
	MicroStar BGA™	ZGU	Controllable count density, variable thickness option availability
	MicroStar Junior™ BGA	ZQE, ZQZ	Smaller sized MicroStar BGA, controllable pin count density
	PicoStar™	YFM	Extremely small sized package, ultra-thin, board embeddable
	BGA	ZVD	Very high pin count density

Through-Hole Packages

	Package Type	Package Designator	Key Characteristics
	Plastic Dual Inline Package (PDIP)	P, N, NT, NTD	Recommended for wave soldering, excellent board-level reliability
	Transistor Outline (TO220)	KC	Very high power handling capability, recommended for wave soldering, mechanically robust

Package Modules

	Package Type	Package Designator	Key Characteristics
	Power Modules	—	Integrated passives, enhanced functionality



→ Packaging

How to Connect the PowerPAD™

The PowerPAD™ should be connected to the appropriate internal signal plane as specified in the product datasheet. Depending on the electrical properties of the thermally conductive epoxy used to connect the Integrated Circuit (IC) to the lead frame, the PowerPAD may have a low impedance connection to the internal signal plane as specified in the product datasheet. Even though the PowerPAD should not be used as your primary signal connection for the IC (use the designated signal pins as specified in the product data sheet), the copper area under the pad can be connected to the specified signal plane per the product data sheet without affecting the device. Since the PowerPAD is intended to remove heat from the part, the size

of the signal plane to which the thermal pad is attached within the board should be as large as needed to dissipate the heat. The via array recommendations in the documents below may vary based on layout constraints and recommendations presented in the product datasheet. The documents below should be used as a general guideline for board design while referring to the product datasheet for application specific via and land pattern requirements.

You can find additional information in the following resources. Technical literature can be accessed online with www.ti.com/lit/litnumber by replacing *litnumber* with one of the following literature numbers shown in parentheses.

- Remember to check the CAD format for your package under “Symbols/ Footprints,” available in all TI Product Folders
- Download the “PowerPAD Made Easy” application brief (SLMA004) in conjunction with the “PowerPAD Thermally Enhanced Package” technical brief (SLMA002)
- Specific information on QFN/SON packages is available in application reports (SLUA271 and SCBA017)
- Visit TI’s Analog & Mixed-Signal KnowledgeBase at: support.ti.com/sc/knowledgebase
- Ask our experts your specific design questions via email by selecting Analog & Mixed-Signal email support in the Contact Tech Support frame at: support.ti.com

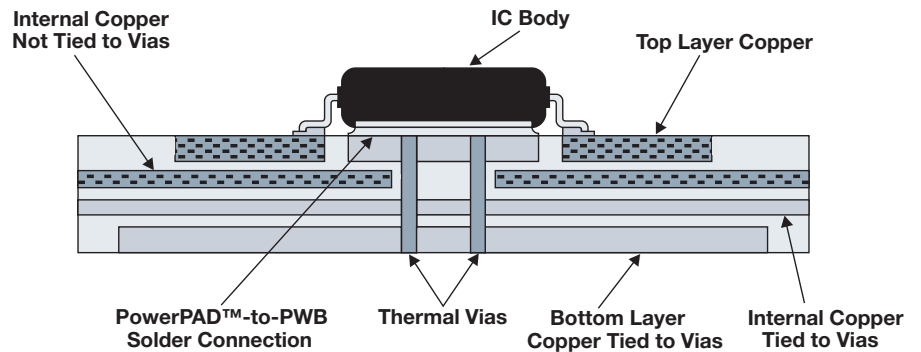
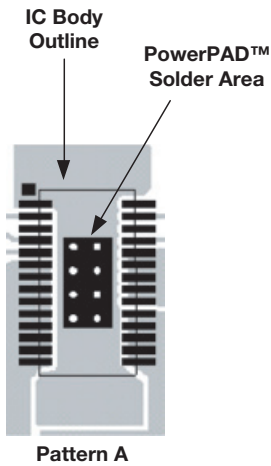

PowerPAD™ package as used by the SWIFT™ product family.

→ Device Index

Device	Page	Device	Page	Device	Page	Device	Page	Device	Page
bq2000/T	66	bq2920x	71	CSD25201W15	39	PTH08T220W	35	TLC5921	55
bq2002/C/E/F	66	bq29330	70, 71	CSD25301W1015	39	PTH08T230/231W	36	TLC59210	55
bq2004/E/H	66	bq2942x	71	CSD25302Q2	39	PTH08T240/241W	36	TLC59211	55
bq2005	66	bq2944x	71	CSD25401Q3	39	PTH08T240F	36	TLC59212	55
bq2013H	70	bq3060	70	CSD75204W15	39	PTH08T250/255W	36	TLC59213/A	55
bq2014H	70	bq500110	6	CSD75205W1015	39	PTH08T260/261W	36	TLC5922	55
bq2016	70	bq51013	6	CSD75211W1723	39	PTH12000L/W	36	TLC5923	55
bq2019	70	bq76PL102	70	CSD75301W1015	39	PTH12010L/W	36	TLC5924	55
bq2022A	68	bq76PL536	8, 70	CSD86311W1723	39	PTH12010Y	36	TLC5925	55
bq2023	70	bq77910	71	CSD86330Q3D	40	PTH12020L/W	36	TLC5926	55
bq2024	68	bq77PL157A4225	71	CSD86350Q5D	27, 40	PTH12030L/W	36	TLC5927	55
bq2031	66	bq77PL900	71	CSD96370Q5M	40	PTH12040W	36	TLC5928	55
bq2060A	70	bq78412	70	DCH01_D	51	PTH12050L/W	36	TLC59281	55
bq20z40-R1	69, 70	bq78PL114	70	DCH01_S	51	PTH12050Y	36	TLC59282	55
bq20z45-R1	69, 70	bq78PL116	70	DCP01_B	51	PTH12060L/W	36	TLC5930	55
bq20z60-R1	69, 70	BUF01900	58	DCP01_DB	51	PTH12060Y	36	TLC5940	55
bq20z65-R1	69, 70	BUF01901	58	DCP02	51	PTMA4	51	TLC59401	55
bq24030	66	BUF05703/4	58	DCP02_D	51	PTN04050A	37	TLC5941	55
bq24031	66	BUF06703	58	DCR01	51	PTN04050C	36	TLC5942	55
bq24040	66	BUF06704	58	LM237	23	PTN78000A	37	TLC5943	55
bq24050	63, 66	BUF07702/3/4	58	LM317	23	PTN78000W/H	36	TLC5944	55
bq24052	66	BUF08630	58	LM317M	23	PTN78020A	37	TLC5945	55
bq24055	66	BUF08800	58	LM337	23	PTN78020W/H	36	TLC5946	55
bq24072	66	BUF08821	58	LP2950	21	PTN78060A	37	TLC59461	55
bq24072T	66	BUF11702/5	58	LP2981	21	PTN78060W/H	36	TLC5947	55
bq24073	66	BUF12800	58	LP2985	21	PTQA4	51	TLC5951	55
bq24074	66	BUF16820	58	LT1054	31	PTQB4	51	TLC5952	55
bq24075T	66	BUF16821	58	MC34063A	18	PTR08060W	36	TLC5960	60, 61
bq24079T	66	BUF20800	58	MC79LxxA	23	PTR08100W	36	TLC59601	55, 61
bq24090	66	BUF20820	58	PT4210	51	PTV03010W	36	TLC5970	55
bq24091	66	BUF22821	58	PTB48520W	51	PTV03020W	36	TLC5971	54, 55
bq24092	66	CSD16301Q2	39	PTB48540	51, 73	PTV05010W	37	TLC77xx	85
bq24093	66	CSD16321Q5	39	PTB48540A/B/C	51	PTV05020W	37	TLV1117LV	22
bq24100/8	65	CSD16321Q5C	40	PTB48560A/B/C	51	PTV08T250W	37	TLV1117-xx	22
bq24153A/56A	66	CSD16322Q5	39	PTB78520W	51	PTV12010L/W	37	TLV62065	15
bq24170/71/72/33	66	CSD16322Q5C	40	PTB78560A/B/C	51	PTV12020L/W	37	TLV62080	15
bq24180/5	66	CSD16323Q3	39	PTD08A006W	34	REG710-2.5	31	TLV700xx	21
bq24210	6, 7, 66	CSD16325Q5	39	PTD08A010W	34	REG710-2.7	31	TLV702xx	21
bq24308	63	CSD16325Q5C	40	PTD08A015W	34	REG710-3	31	TLV702xxP	21
bq24314/A	63	CSD16340Q3	39	PTD08A020W	34	REG710-3.3	31	TLV704xx	21
bq24315	63	CSD16401Q5	39	PTD08A210W	34	REG710-5	31	TLV705xx	21
bq24316	63	CSD16403Q5A	39	PTD08D210W	34	REG71050	31, 61, 87	TLV707xx	21
bq24380	63	CSD16404Q5A	39	PTEA4	51	REG71055	31	TLV707xxP	21
bq24381	63	CSD16406Q3	39	PTH03000W	36	REG711-2.5	31	TLV710	23
bq24382	63	CSD16407Q5	39	PTH03010W	36	REG711-2.7	31	TLV711	23
bq24400/1	66	CSD16407Q5C	40	PTH03010Y	36	REG711-3	31	TLV712xx	21
bq24450	66	CSD16408Q5	39	PTH03020W	36	REG711-3.3	31	TLV809	85
bq24600/10/16/18	64, 66	CSD16408Q5C	40	PTH03030W	36	REG711-5	31	TPPM0110/1	23
bq24617	64, 66	CSD16409Q3	39	PTH03050W	36	TCA6507	61, 87	TPPM0301/2	82
bq24620/30	64, 66	CSD16410Q5A	39	PTH03050Y	36	TL1963A	22	TPPM0303	82
bq24640	64, 66	CSD16411Q3	39	PTH03060W	36	TL317/L/M	23	TPS2010A	82
bq24650	7, 64, 66	CSD16412Q5A	39	PTH03060Y	36	TL3842B/3B/4B/5B	46, 47	TPS2011A	82
bq24707	66	CSD16413Q5A	39	PTH04000W	36	TL4242	55	TPS2012A	82
bq24725	66	CSD16414Q5	39	PTH04040W	36	TL494	46, 47	TPS2013A	82
bq24747	66	CSD17301Q5A	40	PTH04070W	36	TL497A	18	TPS2020/30	82
bq24765	66	CSD17302Q5A	39	PTH04T220/221W	36	TL499A	18	TPS2021/31	82
bq25040/60	66	CSD17303Q5	40	PTH04T230/231W	36	TL5001	29	TPS2022/32	82
bq25070	66	CSD17304Q3	39	PTH04T240/241W	36	TL594	46, 47	TPS2023/33	82
bq26100	68	CSD17305Q5A	40	PTH04T260/261W	36	TL598	46, 47	TPS2024/34	82
bq26150	68	CSD17306Q5A	39	PTH05000W	36	TL7660	31	TPS2041B/51B	82
bq26200	70	CSD17307Q5A	39	PTH05010W	36	TL7700	85	TPS2042B/52B	82
bq26220	70	CSD17308Q3	39	PTH05010Y	36	TL7770-xx	85	TPS2043B/53B	82
bq27000	67	CSD17309Q3	39	PTH05020W	36	TL77xxA/B	85	TPS2044B/54B	82
bq27010	67	CSD17310Q5A	39	PTH05030W	36	TL780-xx	23	TPS2045A/55A	82
bq27200	67	CSD17311Q5	40	PTH05050W	36	TL783	23	TPS2046B/56A	82
bq27210	67	CSD17312Q5	40	PTH05050Y	36	TLC59025	55	TPS2047B/57A	82
bq27500-V130	67	CSD17313Q2	39	PTH05060W	36	TLC59108	55	TPS2048A/58A	82
bq27501	67	CSD17501Q5A	40	PTH05060Y	36	TLC59108F	55	TPS2049	82
bq27505-J4	67	CSD17505Q5A	40	PTH05T210W	36	TLC59116	55	TPS2060/4	82
bq27510-G2	67	CSD17506Q5A	40	PTH08000W	36	TLC59116F	55	TPS2061/5	82
bq27520-G2	67	CSD17507Q5A	40	PTH08080W	36	TLC5916	55	TPS2062A/6	82
bq27541-V200	67, 68	CSD17510Q5A	40	PTH08T210W	36	TLC5917	55	TPS2063/7	82
bq28400	70	CSD23201W10	39	PTH08T220/221W	36	TLC59208F	55	TPS2068/9	82

Device Index (Continued)

Device	Page	Device	Page	Device	Page	Device	Page	Device	Page
TPS2080/1/21	82	TPS2420	76	TPS3801	85	TPS54325	14	TPS61070/1/2/3	18
TPS2085/6/71	82	TPS2421-1	76	TPS3802	85	TPS54326	14	TPS61080	18, 87
TPS2090/1/21	82	TPS2421-2	76	TPS3803	85	TPS54331	14	TPS61080/1	87
TPS2095/6/71	82	TPS2456	75-77	TPS3805	85	TPS54332	14	TPS61081	18
TPS2100/1	82	TPS2458	76	TPS3806	85	TPS54418	14	TPS61085	57
TPS2102/3	82	TPS2459	76	TPS3807	85	TPS54425	14	TPS61087	57
TPS2104/5	82	TPS24700	76	TPS3808	85	TPS54426	14	TPS61090	18
TPS2110A/2A/4A	82	TPS24701	76	TPS3809	85	TPS5450	14	TPS61091/2	18
TPS2111A/3A/5A	82	TPS24710	77	TPS3813	85	TPS54521	14	TPS61093	18
TPS22901	79	TPS24711	77	TPS3818	85	TPS54610/1/2/3/4/5/6	14	TPS61097-33	18
TPS22902	79	TPS24720	77	TPS3820/8-xx	85	TPS54618	14	TPS61100	18
TPS22902B	79	TPS2480	77	TPS3823	85	TPS54620	14	TPS61103/6/7	18
TPS22903	79	TPS2481	77	TPS3824-xx	85	TPS54917	14	TPS61120	18
TPS22906	79	TPS2490	77	TPS3825-xx	85	TPS55383/6	14	TPS61121/2	18
TPS22907	79	TPS2491	77	TPS3836/8	85	TPS56121	14	TPS61131/2	19
TPS22913B	79	TPS2492	77	TPS3837	85	TPS56221	14	TPS61140	61, 87
TPS22921	79	TPS2493	77	TPS386000	83	TPS59116	29	TPS61150A	61, 87
TPS22922	79	TPS2500	7, 80	TPS3860x0	85	TPS59124	29	TPS61160/A	61, 87
TPS22922B	79	TPS2540/41	81, 82	TPS386596	85	TPS59610/11	29	TPS61161/A	61, 87
TPS22924C	79	TPS2552	76, 82	TPS40000/2	28	TPS59621	29	TPS61165	61, 87
TPS22929B	79	TPS2552-1	76, 82	TPS40007/9	28	TPS60100	31	TPS61166	61, 87
TPS22929D	79	TPS2553	76	TPS40020/21	28	TPS60101	31	TPS61170	18
TPS22932B	79	TPS2553-1	76	TPS40040	28	TPS60110	31	TPS61175	18
TPS22941	79	TPS2554/55	76, 82	TPS40041	28	TPS60111	31	TPS61183	61, 87
TPS22942	79	TPS2556/57	76, 82	TPS40042	28	TPS60120/1	31	TPS61185	61, 87
TPS22943	79	TPS2560/61	76, 82	TPS40054/55/57	28	TPS60122/3	31	TPS61195	61, 87
TPS22944	79	TPS2590	76, 82	TPS40056	28	TPS60124/5	31	TPS611995	87
TPS22945	79	TPS2811	49	TPS40075	28	TPS60130/1	31	TPS61200/1/2	18
TPS22946	79	TPS2812	49	TPS40077	28	TPS60132/3	31	TPS61202	6
TPS22949	79	TPS2813	49	TPS40090	29	TPS60140/1	31	TPS61220/21/22	18
TPS22949A	79	TPS2814	49	TPS40091	29	TPS60150/1	31	TPS61222	6
TPS22951	79	TPS2815	49	TPS40100	28	TPS60200/1	31	TPS61240/41	18
TPS22960	79	TPS2816	49	TPS40101	28	TPS60202/3	31	TPS61251	17, 18
TPS2300/01	76	TPS2817	49	TPS40120	29	TPS60204/5	31	TPS61252	18
TPS2310/11	76	TPS2818	49	TPS40132	29	TPS60210/1	31	TPS61260/61	18
TPS2320/21	76	TPS2819	49	TPS40140	29	TPS60212/3	31	TPS61300/1/5	87
TPS2330/31	76	TPS28225	49	TPS40170	28	TPS60230/1	31, 61, 87	TPS61310	87
TPS2342	76	TPS28226	49	TPS40180	29	TPS60240	31	TPS61325	87
TPS2343	76	TPS2828	49	TPS40190	28	TPS60241	31	TPS61500	87
TPS2350	76	TPS2829	49	TPS40192/3	28	TPS60242	31	TPS62040	15
TPS2358	76, 77	TPS2830	49	TPS40195	28	TPS60243	31	TPS62050	15
TPS2359	76, 77	TPS2831	49	TPS40200	28	TPS60250/5	61, 87	TPS62060	15
TPS2363	76	TPS2832	49	TPS40210/18	29	TPS60251	61, 87	TPS62065	15
TPS2375	73	TPS2833	49	TPS40211	53	TPS60300/2	31	TPS62067	15
TPS23750	73	TPS2834	49	TPS40303/4/5	27, 28	TPS60301/3	31	TPS62080	15
TPS2375-1	73	TPS2835	49	TPS43000	29	TPS60310/2	31	TPS62110	15
TPS23753A	73	TPS2836	49	TPS51100	22	TPS60311/3	31	TPS62120	15
TPS23754	73	TPS2837	49	TPS51103	22	TPS60400	31	TPS62122	15
TPS23756	73	TPS2838	49	TPS51315	14	TPS60401	31	TPS62130	15
TPS23757	73	TPS2839	49	TPS53114	28	TPS60402	31	TPS62140	15
TPS2376	73	TPS2848	49	TPS53124	28	TPS60403	31	TPS62150	15
TPS2376-H	73	TPS2849	49	TPS53125/26/27	28	TPS60500	31	TPS62160	15
TPS2377	73	TPS3103	85	TPS53219	29	TPS60501	31	TPS62170	15
TPS23770	73	TPS3106	85	TPS53311	14	TPS60502	31	TPS62200	15
TPS2377-1	73	TPS3110	85	TPS54010	14	TPS60503	31	TPS62220	15
TPS2384	73	TPS3123	85	TPS54040	14	TPS61010	18	TPS62230	15
TPS23841	73	TPS3124	85	TPS54060	14, 20	TPS61011/2/3	18	TPS62240	15
TPS23851	73	TPS3125	85	TPS5410	14	TPS61014/5/6	18	TPS62250	15
TPS2390	76	TPS3126	85	TPS54140	14	TPS61020	18	TPS62260	15
TPS2391	76	TPS3128	85	TPS54160	14, 18, 53	TPS61024/5/7	18	TPS62270	15
TPS2392	76	TPS3305-xx	85	TPS5420	14	TPS61026/9	18	TPS62290	15
TPS2393	76	TPS3306-xx	85	TPS54218	14	TPS61028	18	TPS62360	15
TPS2393A	76	TPS3307-xx	85	TPS54225	14	TPS61030/1/2	18	TPS62400	15
TPS2394	76	TPS3510/1	85	TPS54226	14	TPS61040	18, 61, 87	TPS62410	15
TPS2395	76	TPS3513/4	85	TPS54231/2/3	14	TPS61041	18, 61, 87	TPS62420	15
TPS2398	76	TPS3600	85	TPS54240	14	TPS61042	61, 87	TPS62510	15
TPS2399	76	TPS3606-33	85	TPS54260	14	TPS61043	61, 87	TPS62560	15
TPS2400	76	TPS3610	85	TPS54283/6	14	TPS61045	61, 87	TPS62590	15
TPS2410	77	TPS3613-01	85	TPS54290/1/2	14	TPS61050/2	87	TPS62612	15
TPS2411	77	TPS3619	85	TPS5430	14, 18	TPS61054/5	87	TPS62620	15
TPS2412	77	TPS3705-xx	85	TPS54310/1/2/3/4/5/6	14	TPS61060	61, 87	TPS62650	15
TPS2413	77	TPS3707-xx	85	TPS54318	14	TPS61061	61, 87	TPS62660	15
TPS2419	77	TPS3800	85	TPS54320	14	TPS61062	61, 87	TPS62674	15

➔ Device Index (Continued)

Device	Page	Device	Page	Device	Page	Device	Page	Device	Page
TPS62690	15	TPS65181B	56, 58	TPS732xx	21	TPS92010	53	UCC28610	4, 46, 47
TPS62700	15	TPS65182B	58	TPS734xx	21	TPS92020	5, 53	UCC28810	5, 53
TPS62750	15	TPS65190	57	TPS735xx	22	TPS92210	5, 52, 53	UCC28811	5, 53
TPS63000/1/2	19	TPS65191	57	TPS736xx	22	TWL6030/40	25	UCC2891/3	46, 47
TPS63010/11/12	19	TPS65192	57	TPS737xx	22	UA723	23	UCC2892/4	46, 47
TPS63020	19	TPS65193	57	TPS742xx	22	UA78Lxx/A	23	UCC28950	46, 47
TPS63030/31	19	TPS65194	57	TPS743xx	22	UA78Mxx	23	UCC2897A	46, 47
TPS63060/1	19	TPS65200	25	TPS744xx	22	UA78xx	23	UCC35701/2	46, 47
TPS63700	18	TPS65210	25	TPS747xx	22	UA79Mxx	23	UCC35705/6	46, 47
TPS64200/1/2/3/10	29	TPS65215	25	TPS748xx	22	UA79xx	23	UCC3580-1/-2/-3/-4	46, 47
TPS65000/6	25	TPS65220	25	TPS749xx	22	UC28023	46, 47	UCC3583	46, 47
TPS65010/1/2/3/4	25	TPS65230/1	25	TPS75003	25	UC28025	46, 47	UCC37321	49
TPS65020/1/2	25	TPS65232	25	TPS75103/5	61, 87	UC3524A	46, 47	UCC37322	49
TPS65023x	25	TPS65250/1	24, 25	TPS752xx	22	UC3525B	46, 47	UCC3800/1/2/3/4/5	46, 47
TPS650240/1/2/3/4/5	25	TPS65252	25	TPS756xx	22	UC3526A	46, 47	UCC3806	46, 47
TPS650250	25	TPS65257/8	25	TPS758xx	22	UC3714	49	UCC3807-1-2-3	46, 47
TPS65050/1/2/4/6	25	TPS657051/2	25	TPS759xx	22	UC3715	49	UCC3808-1/-2/A-1/A-2	46, 47
TPS65053/8	25	TPS65708	25	TPS767D3xx	23	UC3823A/B	46, 47	UCC38083/4/5/6	46, 47
TPS65070/2/3	25	TPS65720/1	25	TPS767xx	22	UC3824	46, 47	UCC3809-1-2	46, 47
TPS65072	24	TPS65831	25	TPS768xx	22	UC3825A/B	46, 47	UCC3810	46, 47
TPS65100	57	TPS658621/2/3/9	25	TPS769xx	21	UC3827-1/-2	46, 47	UCC3813-0/1/2/3/4/5	46, 47
TPS65101	57	TPS65910	24, 26	TPS773xx	21	UC3842A/3A/4A/5A	46, 47	UCC384-x	22
TPS65105	57	TPS65910x	25	TPS775xx	22	UC3846/56	46, 47	UCC3884	46, 47
TPS65120	58	TPS65911x	25	TPS776xx	22	UC385-x	22	UCC3888/89	46, 47
TPS65121	58	TPS65921	25	TPS777xx	22	UC3875/6/7	46, 47	UCC3895	46, 47
TPS65123	58	TPS65930	25	TPS780xx	21	UC3879	46, 47	UCC38C40/1/2/3/4/5	46, 47
TPS65124	58	TPS65950	25	TPS78233	6	UC3909	66	UCC3912	76
TPS65130	58	TPS65951	25	TPS782xx	21	UCC24610	48, 49	UCC3915	76
TPS65131	58	TPS701xx	23	TPS783xx	21	UCC25600	43, 46, 47, 60, 61	UCC3918	76
TPS65136	58	TPS703xx	23	TPS786xx	22	UCC25710	61	UCC3919	76
TPS65137	58	TPS707xx	23	TPS789xx	21	UCC27200	44, 49	UCCx946	85
TPS65140	57	TPS712xx	23	TPS797xx	21	UCC27201	49	UCD3020	50
TPS65141	57	TPS713xx	23	TPS799xx	21	UCC27221	49	UCD7100	34, 49
TPS65145	57	TPS714xx	21	TPS7A3001	20	UCC27222	49	UCD7201	34, 49
TPS65146	57	TPS715Axx	21	TPS7A30xx	22	UCC27223	49	UCD7230	49
TPS65148	57	TPS715xx	21	TPS7A40xx	21	UCC27323	49	UCD7231	34
TPS65149	56, 57	TPS717xx	21	TPS7A45	22	UCC27324	45, 49	UCD7232	34
TPS65150	57	TPS718xx	23	TPS7A4901	20	UCC27325	49	UCD7242	34
TPS65160/A	57	TPS719xx	23	TPS7A49xx	21	UCC27423	49	UCD74103	34
TPS65161/A/B	57	TPS720xx	21	TPS7A60xx	21	UCC27424	49	UCD74106	34
TPS65162	57	TPS723xx	22	TPS7A80xx	22	UCC27425	49	UCD90120	84, 85
TPS65163	57	TPS725xx	22	TPS80010	25	UCC28089	46, 47	UCD90124	84, 85
TPS65165	57	TPS727xx	21	TPS82671	11, 12	UCC28220/1	46, 47	UCD9081	85
TPS65168	57	TPS728xx	21	TPS84620	12	UCC28230/1	43, 44, 46, 47	UCD9222/442	34
TPS65170	57	TPS730xx	21	TPS92001	53	UCC28250	44, 46, 47	UCD9224	34
TPS65180B	58	TPS731xx	21	TPS92002	53	UCC28600	4, 46, 47	UCD9248/6	34

Automotive Qualified Devices

Device	Page	Device	Page	Device	Page	Device	Page	Device	Page
bq24030	66	TPS3808	85	TPS54260	14	TPS62290	15	TPS767xx	22
bq24031	66	TPS3809	85	TPS5430	14, 18	TPS62410	15	TPS768xx	22
bq24105	65	TPS3813	85	TPS54310/1/2/3/4/5/6	14	TPS62420	15	TPS769xx	21
REG71055	31	TPS3820/8-xx	85	TPS54331	14	TPS62590	15	TPS775xx	22
TL1963A	22	TPS3823	85	TPS5450	14	TPS63000	19	TPS776xx	22
TL4242	55	TPS3824-xx	85	TPS54610/1/2/3/4/5/6	14	TPS65023x	25	TPS782xx	21
TL5001	29	TPS3825-xx	85	TPS60400	31	TPS650241/3/4	25	TPS797xx	21
TLC5916	55	TPS3836/8	85	TPS60401	31	TPS650250	25	TPS799xx	21
TLC5917	55	TPS3837	85	TPS60402	31	TPS65100	57	TPS7A60xx	21
TLC5926	55	TPS402008	28	TPS60403	31	TPS65140	57	UA78Mxx	23
TLC5927	55	TPS40210	29	TPS61029	18	TPS65145	57	UCC27200	49
TLC5941	55	TPS40211	53	TPS61040	18, 61, 87	TPS658629	25	UCC27201	49
TLC77xx	85	TPS54040	14	TPS61041	18, 61, 87	TPS701xx	23	UCC27423	49
TLV700xx	21	TPS54060	14, 20	TPS61071	18	TPS715xx	21	UCC27424	49
TPS2829	49	TPS5410	14	TPS61085	57	TPS732xx	21	UCC27425	49
TPS3306-xx	85	TPS54140	14	TPS61161	61, 87	TPS737xx	22	UCC28220	46, 47
TPS3307-xx	85	TPS54160	14, 18, 53	TPS61240	18	TPS747xx	22	UCCx946	85
TPS3803	85	TPS5420	14	TPS62110	15	TPS752xx	22		
TPS3805	85	TPS54240	14	TPS62260	15	TPS767D3xx	23		

→ Device Index (Continued)

HiRel Devices

Device	Page	Device	Page	Device	Page	Device	Page	Device	Page
TPS62110	15	TPS3803	85	TPS5430	14, 18	TPS744xx	22	UC3842A/5A	46, 47
TL494	46, 47	TPS3805	85	TPS54310/1/2/3/4/5/6	14	TPS752xx	22	UC3846	46, 47
TL5001	29	TPS3808	85	TPS5450	14	TPS767D3xx	23	UCC27423	49
TL598	46, 47	TPS3809	85	TPS54610/1/2/3/4/5/6	14	TPS767xx	22	UCC27424	49
TL77xxA/B	85	TPS3813	85	TPS703xx	23	TPS768xx	22	UCC28220	46, 47
TLC77xx	85	TPS3836/8	85	TPS707xx	23	TPS769xx	21	UCC3806	46, 47
TLV809	85	TPS3837	85	TPS712xx	23	TPS775xx	22		
TPS2818	49	TPS40054/55/57	28	TPS715xx	21	TPS776xx	22		
TPS2819	49	TPS402008	28	TPS731xx	21	TPS797xx	21		
TPS3106	85	TPS5410	14	TPS732xx	21	UA79xx	23		
TPS3619	85	TPS5420	14	TPS736xx	22	UC3825	46, 47		

Connect with your Power-Management peers and customers to ask questions, share knowledge, explore ideas, and solve problems.

Join the discussion today!

www.ti.com/e2epower



TI E2E™
Community
engineer.to.engineer,
solving problems

Reference Design Cookbooks for Power Management Products

A few of the designs included are:

- Synchronous Buck Converter
- Green-Mode AC Input Flyback
- Multi-Channel Buck for DDR
- Synchronous Battery-Pack Charger
- Non-Isolated Non-Synchronous SEPIC
- Battery Charger Front-End Protection Circuit
- Small LCD Backlight with Digital and PWM Dimming
- Wireless-Controlled Triple LED Drive

These cookbooks and other reference designs are available online at:

www.ti.com/powerreferencedesigns



TI Worldwide Technical Support

Internet

TI Semiconductor Product Information Center Home Page

support.ti.com

TI E2E™ Community Home Page

e2e.ti.com

Product Information Centers

Americas	Phone	+1(972) 644-5580
Brazil	Phone	0800-891-2616
Mexico	Phone	0800-670-7544
	Fax	+1(972) 927-6377
	Internet/Email	support.ti.com/sc/pic/americas.htm

Europe, Middle East, and Africa

Phone	
European Free Call	00800-ASK-TEXAS (00800 275 83927)
International	+49 (0) 8161 80 2121
Russian Support	+7 (4) 95 98 10 701
Note: The European Free Call (Toll Free) number is not active in all countries. If you have technical difficulty calling the free call number, please use the international number above.	

Fax	+49 (0) 8161 80 2045
Internet	support.ti.com/sc/pic/euro.htm
Direct Email	asktexas@ti.com

Japan

Phone	Domestic	0120-92-3326
Fax	International	+81-3-3344-5317
	Domestic	0120-81-0036
Internet/Email	International	support.ti.com/sc/pic/japan.htm
	Domestic	www.tij.co.jp/pic

Important Notice: The products and services of Texas Instruments Incorporated and its subsidiaries described herein are sold subject to TI's standard terms and conditions of sale. Customers are advised to obtain the most current and complete information about TI products and services before placing orders. TI assumes no liability for applications assistance, customer's applications or product designs, software performance, or infringement of patents. The publication of information regarding any other company's products or services does not constitute TI's approval, warranty or endorsement thereof.

Asia

Phone	
International	+91-80-41381665
Domestic	Toll-Free Number
Note: Toll-free numbers do not support mobile and IP phones.	
Australia	1-800-999-084
China	800-820-8682
Hong Kong	800-96-5941
India	1-800-425-7888
Indonesia	001-803-8861-1006
Korea	080-551-2804
Malaysia	1-800-80-3973
New Zealand	0800-446-934
Philippines	1-800-765-7404
Singapore	800-886-1028
Taiwan	0800-006800
Thailand	001-800-886-0010
Fax	+8621-23073686
Email	tiasia@ti.com or ti-china@ti.com
Internet	support.ti.com/sc/pic/asia.htm

B122010

Trademarks: The platform bar, Analog e-LAB, Auto-Track, bqTESLA, C2000, D-CAP+, D-CAP Mode, D-CAP2 Mode, DualCool, E2E, EasyScale, Fusion Digital Power, Green Rectifier, iHVM, Impedance Track, MicroSiP, MicroStar BGA, MicroStar Junior, MSP430, Natural Interleaving, NexFET, OMAP, PicoStar, POLA, PowerLAN, PowerPAD, Predictive Gate Drive, Pspice, SDQ, SimpLEDdrive, Sitara, SmartReflex, SWIFT, SwitcherPro, TINA-TI, TPS40K, TrueDrive and TurboTrans are trademarks of Texas Instruments. ARM7 is a trademark and ARM is a registered trademark of ARM Limited. The *Bluetooth* word mark and logos are owned by the Bluetooth SIG, Inc., and any use of such marks by Texas Instruments is under license. CompactPCI and MicroTCA are registered trademarks of PCI Computer Manufacturers Group, Inc. (PICMG). ExpressCard is a trademark of the Personal Computer Memory Card International Association (PCMCIA). PCI Express and PCI-X are registered trademarks of PCI-SIG Corporation. PMBus is a trademark of System Management Interface Forum, Inc. PXI Express is a registered trademark of PXI Systems Alliance, Inc. Sun is a registered trademark of Sun Microsystems Incorporated. ZigBee is a registered trademark of the ZigBee Alliance. All other trademarks are the property of their respective owners.

IMPORTANT NOTICE

Texas Instruments Incorporated and its subsidiaries (TI) reserve the right to make corrections, modifications, enhancements, improvements, and other changes to its products and services at any time and to discontinue any product or service without notice. Customers should obtain the latest relevant information before placing orders and should verify that such information is current and complete. All products are sold subject to TI's terms and conditions of sale supplied at the time of order acknowledgment.

TI warrants performance of its hardware products to the specifications applicable at the time of sale in accordance with TI's standard warranty. Testing and other quality control techniques are used to the extent TI deems necessary to support this warranty. Except where mandated by government requirements, testing of all parameters of each product is not necessarily performed.

TI assumes no liability for applications assistance or customer product design. Customers are responsible for their products and applications using TI components. To minimize the risks associated with customer products and applications, customers should provide adequate design and operating safeguards.

TI does not warrant or represent that any license, either express or implied, is granted under any TI patent right, copyright, mask work right, or other TI intellectual property right relating to any combination, machine, or process in which TI products or services are used. Information published by TI regarding third-party products or services does not constitute a license from TI to use such products or services or a warranty or endorsement thereof. Use of such information may require a license from a third party under the patents or other intellectual property of the third party, or a license from TI under the patents or other intellectual property of TI.

Reproduction of TI information in TI data books or data sheets is permissible only if reproduction is without alteration and is accompanied by all associated warranties, conditions, limitations, and notices. Reproduction of this information with alteration is an unfair and deceptive business practice. TI is not responsible or liable for such altered documentation. Information of third parties may be subject to additional restrictions.

Resale of TI products or services with statements different from or beyond the parameters stated by TI for that product or service voids all express and any implied warranties for the associated TI product or service and is an unfair and deceptive business practice. TI is not responsible or liable for any such statements.

TI products are not authorized for use in safety-critical applications (such as life support) where a failure of the TI product would reasonably be expected to cause severe personal injury or death, unless officers of the parties have executed an agreement specifically governing such use. Buyers represent that they have all necessary expertise in the safety and regulatory ramifications of their applications, and acknowledge and agree that they are solely responsible for all legal, regulatory and safety-related requirements concerning their products and any use of TI products in such safety-critical applications, notwithstanding any applications-related information or support that may be provided by TI. Further, Buyers must fully indemnify TI and its representatives against any damages arising out of the use of TI products in such safety-critical applications.

TI products are neither designed nor intended for use in military/aerospace applications or environments unless the TI products are specifically designated by TI as military-grade or "enhanced plastic." Only products designated by TI as military-grade meet military specifications. Buyers acknowledge and agree that any such use of TI products which TI has not designated as military-grade is solely at the Buyer's risk, and that they are solely responsible for compliance with all legal and regulatory requirements in connection with such use.

TI products are neither designed nor intended for use in automotive applications or environments unless the specific TI products are designated by TI as compliant with ISO/TS 16949 requirements. Buyers acknowledge and agree that, if they use any non-designated products in automotive applications, TI will not be responsible for any failure to meet such requirements.

Following are URLs where you can obtain information on other Texas Instruments products and application solutions:

Products

Audio	www.ti.com/audio
Amplifiers	amplifier.ti.com
Data Converters	dataconverter.ti.com
DLP® Products	www.dlp.com
DSP	dsp.ti.com
Clocks and Timers	www.ti.com/clocks
Interface	interface.ti.com
Logic	logic.ti.com
Power Mgmt	power.ti.com
Microcontrollers	microcontroller.ti.com
RFID	www.ti-rfid.com
RF/IF and ZigBee® Solutions	www.ti.com/lprf

Applications

Communications and Telecom	www.ti.com/communications
Computers and Peripherals	www.ti.com/computers
Consumer Electronics	www.ti.com/consumer-apps
Energy and Lighting	www.ti.com/energy
Industrial	www.ti.com/industrial
Medical	www.ti.com/medical
Security	www.ti.com/security
Space, Avionics and Defense	www.ti.com/space-avionics-defense
Transportation and Automotive	www.ti.com/automotive
Video and Imaging	www.ti.com/video
Wireless	www.ti.com/wireless-apps

TI E2E Community Home Page

e2e.ti.com

Mailing Address: Texas Instruments, Post Office Box 655303, Dallas, Texas 75265
Copyright © 2011, Texas Instruments Incorporated