

## DCP01/02 Single or dual Vout Low Noise Power Supply 1W/2W With Soft Power-on delay

NOTE : Adding in SVS decreases in rush current and its affect on the power source during power-up mode and its current sink capabilities during  $Dv/Dt$  transitions.

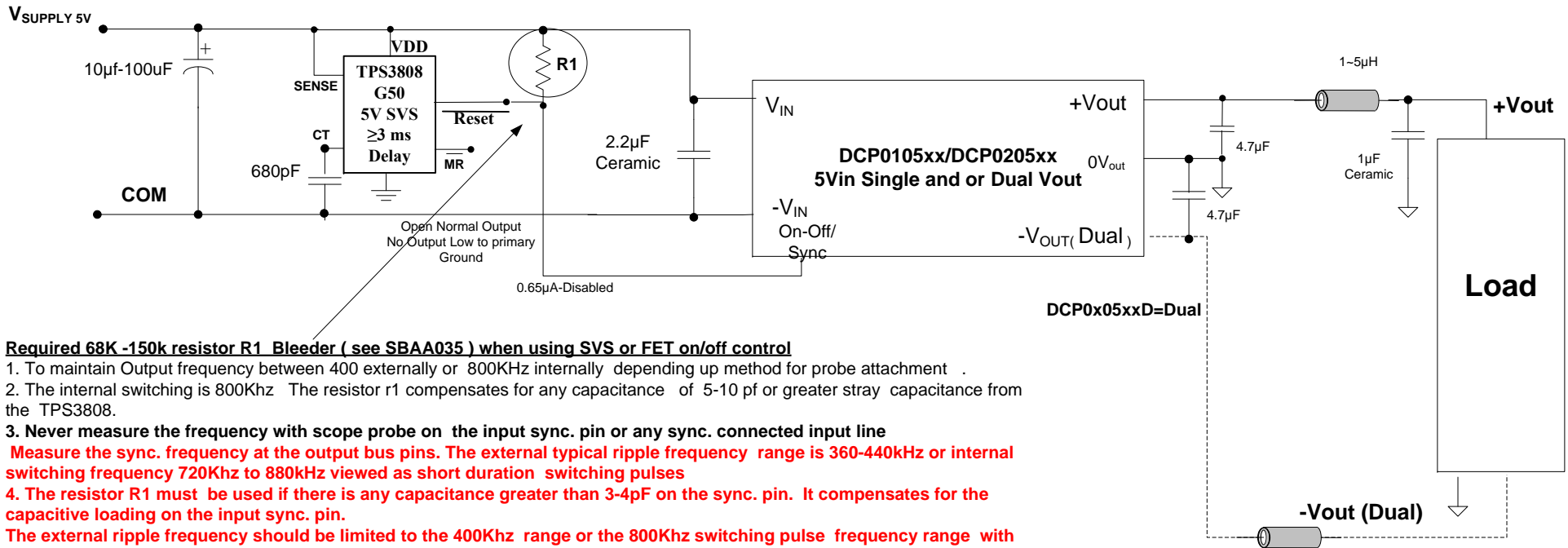

### Required 68K -150k resistor R1 Bleeder ( see SBAA035 ) when using SVS or FET on/off control

1. To maintain Output frequency between 400 externally or 800KHz internally depending up method for probe attachment .
2. The internal switching is 800Khz The resistor r1 compensates for any capacitance of 5-10 pf or greater stray capacitance from the TPS3808.
3. Never measure the frequency with scope probe on the input sync. pin or any sync. connected input line  
Measure the sync. frequency at the output bus pins. The external typical ripple frequency range is 360-440kHz or internal switching frequency 720Khz to 880kHz viewed as short duration switching pulses
4. The resistor R1 must be used if there is any capacitance greater than 3-4pF on the sync. pin. It compensates for the capacitive loading on the input sync. pin.  
The external ripple frequency should be limited to the 400Khz range or the 800Khz switching pulse frequency range with limits as stated above.

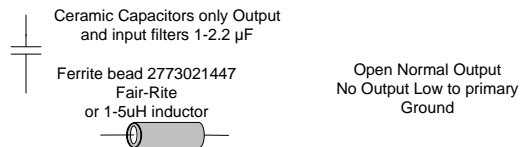

10/5/2010

Note:  
Input Inductor recommended for attenuation input noise  
Output inductors and ceramic capacitors suggested for Analog low noise filter

10/1/2013  
Texas Instruments  
Tom Guerin  
tguerin@ti.com