

Title	
<b>100V 50W DC Module</b>	
Sheet 1	of 2

Variant:	Standard
Revision:	<b>V 1.0</b>

Created by:	DI Gerhard Kreuzer
Checked by:	ISHIDBEN-T
File:	100V 50W Power Module DEV.SchDoc

Number:	<b>M9032.4.1</b>
Date:	07.04.2014
Time:	07:53:26

**lift<sup>off</sup>**  
 Dep.: GeoMonitor  
 Karlsgasse 6  
 3001 Tullinger Kogel  
 Austria  
 Tel: +43 2273 80222  
[www.liftoff.at](http://www.liftoff.at)

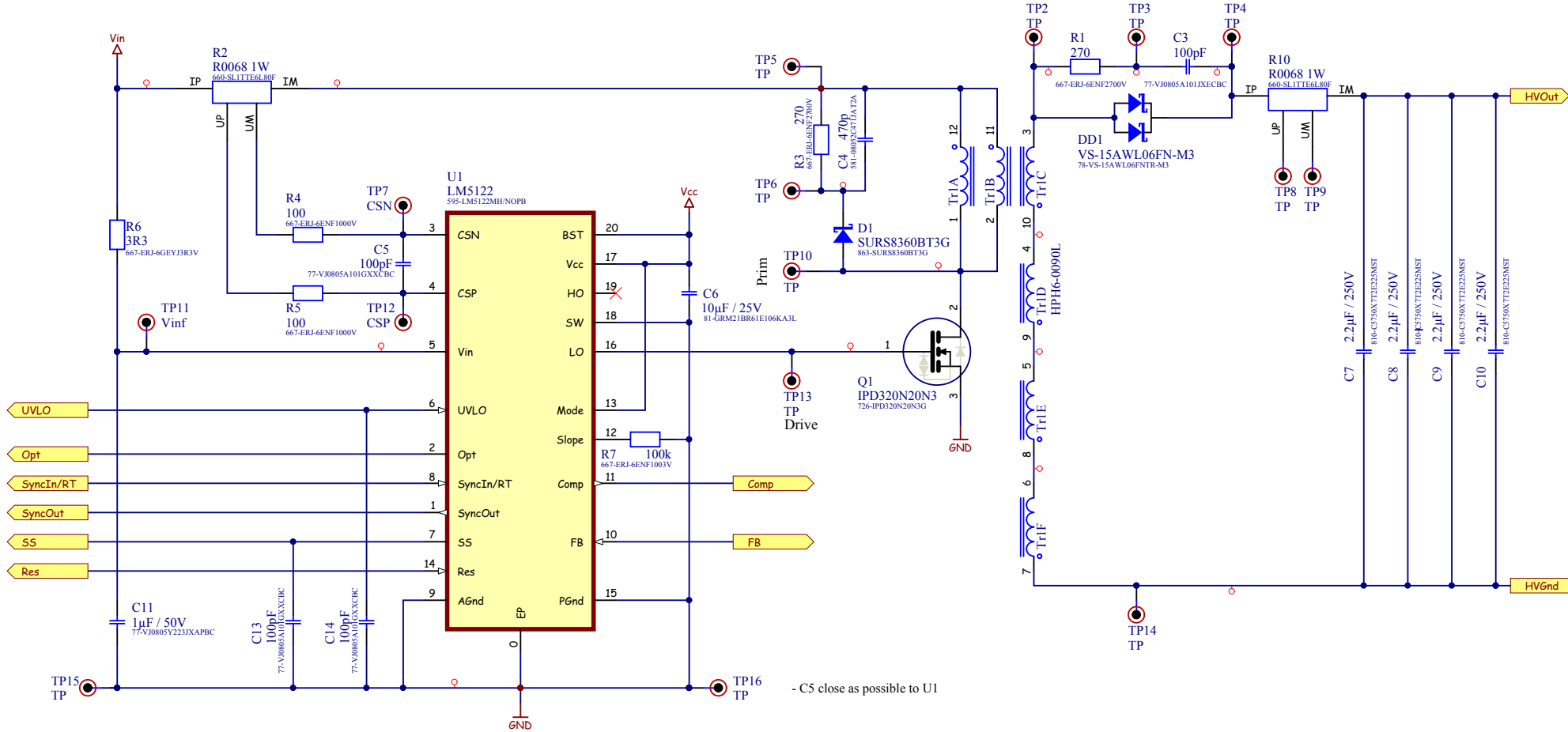

- C5 close as possible to U1

Title	
<b>100V 50W isolated Power Module</b>	
Sheet 2	of 2

Variant:	Standard
Revision:	V 1.0

Created by:	DI Gerhard Kreuzer
Checked by:	ISH/DEN-T
File:	Flyback Module 100V DEV.SchDoc

Number:	M9032.4.2
Date:	07.04.2014
Time:	07:53:26

	Dep.: GeoMonitor Karlsgasse 6 3001 Tullingerkogel Austria Tel: +43 2273 80222
	<a href="http://www.liftoff.at">www.liftoff.at</a>

Comment	Description	Designator	Footprint	LibRef	Quantity
33µF / 50V	Alu Elektrolyt Capacitor Low ESR	C1, C2	EEHZA1HXXX Size D8 Panasonic	CERCO	2
100pF	Ceramic Capacitor	C3, C5, C13, C14	SMD C 2012 (0805)	CERCO	4
470p	Ceramic Capacitor	C4	SMD C 2012 (0805)	CERCO	1
10µF / 25V	Ceramic Capacitor	C6, C12	SMD C 2012 (0805)	CERCO	2
2.2µF / 250V	Ceramic Capacitor	C7, C8, C9, C10	CAPC2220(5750)165_N	CERCO	4
1µF / 50V	Ceramic Capacitor	C11	SMD C 2012 (0805)	CERCO	1
Edge Connector	Edge Connector for TE 8-5530843-3 Socket	Conn1	TE 8-5530843-3 Edge 24 p	CON24	1
SURS8360BT3G	Schottky Diode	D1	DIODE SMB	DIODE SCHOTTKY	1
VS-15AWL06FN-M3	Common Cathode	DD1	TO-252_L	Schottky Diode Dual Common Cathode	1
CON2		J1	JUMP1X1	CON2	1
IPD320N20N3	N-Channel Enhancement Mode Field Effect Transistor	Q1	TO-252_L	MOSFET N 2	1
270	Resistor 1/4 Watt	R1, R3	SMD R 2012 (0805)	R	2
R0068 1W	Shunt 4-Wire	R2, R10		R4Wire	2
100	Resistor 1/4 Watt	R4, R5	SMD R 2012 (0805)	R	2
3R3	Resistor 1/4 Watt	R6	SMD R 2012 (0805)	R	1
100k	Resistor 1/4 Watt	R7	SMD R 2012 (0805)	R	1
10k	Resistor 1/4 Watt	R8	SMD R 2012 (0805)	R	1
31k	Resistor 1/4 Watt	R9	SMD R 2012 (0805)	R	1
LD2980CM50TR	Voltageregulator positiv w inhibit	REG1		VOLTREG POSITIV w inhibit	1
GTCC23-141M-R01-2	Surge Arrester	SA1	GTCS23-900M-R01-2	Surge_Arrester	1
Vinf	Testpoint	TP1, TP11	TP 20-31314x	TP	2
TP	Testpoint	TP2, TP3, TP4, TP5, TP6, TP8, TP9, TP10, TP13, TP14, TP15, TP16	TP 20-31314x	TP	12
CSN	Testpoint	TP7	TP 20-31314x	TP	1
CSP	Testpoint	TP12	TP 20-31314x	TP	1
HPHx	Coilcrafts HexaPath Series	Tr1	HP6 HPH6	HexaPath HPH3 HPH4 HPH5 HPH6	1
LM5122	Wide Input Synchronous Boost Controller with Multiple Phase Capability	U1	HTSSOP20	LM5122	1
SN74LVS1G34	Single Buffer Gate	U2		SN74LVS1G34	1